

# MPLUS

SUPPLEMENTARY PRODUCT LINE  
FOR SPECIFIC APPLICATIONS



*Mplus...*

# *Mplus...*



**MPLUS TOOLING**

**SUPPLEMENTARY PRODUCT LINE  
FOR SPECIFIC APPLICATIONS**

# MITSUBISHI MATERIALS

## GENERAL CATALOGUE C010 2025 – 2027

### TARGETED, COMPACT, HANDY.

Mitsubishi Materials' wide product portfolio is now shown in catalogues that represent individual application areas, offering users fast and easy access to targeted product information.

There is now a set of catalogues in small, practical sizes that comprise the following five volumes:

- TURNING TOOLS
- DRILLING TOOLS
- SOLID MILLING TOOLS
- INDEXABLE MILLING TOOLS
- MPLUS

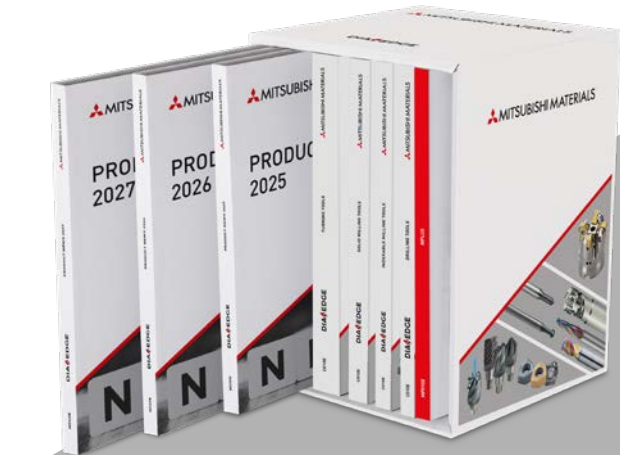

EASY HANDLING

HIGHER FLEXIBILITY

INDIVIDUAL APPLICATION AREAS

The slipcase provided enables easy storage and offers the required space for all future catalogues, including the product news brochures that will be published within the life cycle of the catalogue. Each new product news brochure published within the catalogue cycle will completely replace the previous version. Therefore, please dispose of old versions when new ones are supplied to ensure that the collection is up to date.

### NOTES:

- With this publication, all previous general catalogues and product news brochures lose their validity.
- The product news catalogues are released twice a year, in April and October.
- The new general catalogue can be ordered only as a set of five. Order number: **C010E**



### DIGITAL VERSION

For the digital version of the catalogue, please scan the QR code or visit our mediastore: [www.mhg-mediastore.net](http://www.mhg-mediastore.net)

Visit also:

[www.mmc-carbide.com](http://www.mmc-carbide.com)

# MPLUS



## **COOPERATION - OVERCOMING BOUNDARIES**

MPlus is a complementary product line that enriches the existing product range.

A wide range of supplementary tools in cooperation with partners across Europe that meet specific customer needs.

Outstanding tools and sophisticated tooling solutions for the metalworking industry.



# *Mplus...*



# INDEX

## TURNING TOOLS

### **MINI-EY-IC/MINI-EY**

Precision grooving system. With and without internal coolant supply.

6

**NEW**

### **G80A**

Parting off system for Tornos multi-spindle machines.

17

### **ISO PSC TOOL HOLDERS**

Wide range of PSC holders for multiple applications.

31

## INDEXABLE MILLING TOOLS

### **415SD**

First choice for high-feed machining of titanium alloys.

86

### **ARM**

Multi-functional high feed cutter for mould & die machining.

93

### **SIDE AND FACE MILLING CUTTER SERIES**

Side and face machining with low cutting resistance, vertical mount, double-sided inserts for DCV series.

101

### **LSE445-E**

General purpose face milling cutters.

116

### **RRD**

Round insert type cutters – Versatile performance and long tool life.

120

## DRILLING TOOLS

### **TAF**

Indexable insert drill – Featuring a tough body that creates low drilling noise.

135

---

# MINI-EY-SERIES

---

PRECISION GROOVING SYSTEM

---



*Mplus...*

# MINI-EY-IC

## WITH INTERNAL COOLANT

The advanced Mini-EY-IC series with internal coolant supply provides a positive step in usability. The improved coolant supply reduces heat generation as well as enabling longer tool life. Optimised chip control and higher cutting parameters, plus increased wear resistance means greater efficiencies can be achieved.

### PRODUCT RANGE

- Insert width: 2 mm and 3 mm
- Holder size: 12 x 12, 16 x 16, 20 x 20
- Hand: R/L
- Max. cut off diameter: Ø 25 mm, 32 mm, 42 mm

### APPLICATION

- External grooving and cut off

### FEATURES

- Higher cutting parameters
- Cost effective double sided inserts
- Sizes 12 & 16 with clamping screw axis tilted at 115° for easy, on machine access
- Internal coolant supply

LONGER TOOL LIFE

EXCELLENT SURFACES

IMPROVED CHIP CONTROL

INCREASED WEAR RESISTANCE

## WITH INTERNAL COOLANT



# MINI-EY

## WITH EXTERNAL COOLANT

The Mini-EY is designed for Swiss-type lathes as a precision grooving system. A range of suitable insert grades and chipbreakers makes it usable for steels, stainless steels, cast irons and difficult-to-cut materials. Complete with economical double sided inserts.

### PRODUCT RANGE

- Insert width: 1.5 mm – 3.0 mm
- Holder size: 10x10, 12x12, 16x16
- Hand: R/L
- Max. cut off diameter: Ø 25 mm, 32 mm

### APPLICATION

- External grooving and cut off

### FEATURES

- Cost effective double sided Inserts
- Designed for Swiss-type lathes



**LONG TOOL LIFE**

**GOOD SURFACE FINISHES**

**EXCELLENT CHIP CONTROL**

TMplus...



# MINI-EY-IC

## WITH INTERNAL COOLANT SUPPLY

### 00° type mono block holder

Insert	GY2M	-GS	Insert	GY2M	-GS
		-GM			-GM
Insert	GY2M	-GU	Insert	GY2M	-GU
Insert	GY2G	-MF	Insert	GY2M	R/L
					-GM

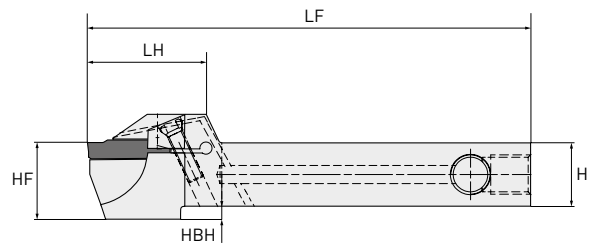
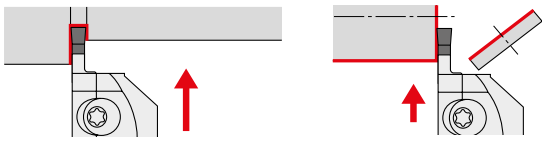

Right hand tool holder shown.

Order number	Stock	Seat size	CW	Hand	CDX	CUTDIA	H	B	LF	LH	HF	HBH
EYHL1212D125-IC	●	D	2.0	L	12.5	25	12	12	110	30	16	4
EYHR1212D125-IC	●			R	12.5	25	12	12	110	30	16	4
EYHL1212F125-IC	●	F	3.0	L	12.5	25	12	12	110	30	16	4
EYHR1212F125-IC	●			R	12.5	25	12	12	110	30	16	4
EYHL1616D160-IC	●	D	2.0	L	16.0	32	16	16	110	33.5	16	—
EYHR1616D160-IC	●			R	16.0	32	16	16	110	33.5	16	—
EYHL1616F160-IC	●	F	3.0	L	16.0	32	16	16	110	33.5	16	—
EYHR1616F160-IC	●			R	16.0	32	16	16	110	33.5	16	—
EYHL2020F210-IC	●			L	21.0	42	20	20	125	37	20	—
EYHR2020F210-IC	●			R	21.0	42	20	20	125	37	20	—

1/1

- When using insert widths 2.39 mm and 2.50 mm with E type seat sizes, in F type holders, the centre height will differ.
- Dimensions shown are when the gauge insert is used. If other insert geometries are used then LF, LH and HF values may vary.
- Size 12 holder without socket.
- Sizes 12 & 16 with clamping screw axis tilted at 115° for easy on machine access.







# MINI-EY-IC

## CUTTING MODE AND INSERTS

Holder number	Cutting mode (Right hand holder shown)	Insert Geometry / Insert number
EYHC1212D125-IC		GY2M0300F030N-GU
EYHC1212F125-IC		GY2M0200D020N-GU
EYHC1616D160-IC		GY2M0200D020N-GS
EYHC1616F160-IC		GY2M0300F020N-GS
EYHC2020F210-IC		GY2M0200D020N-GM
		GY2M0300F030N-GM
		GY2M0200D020R05-GM
		GY2M0200D020L05-GM
		GY2M0300F030R05-GM
		GY2M0300030L05-GM

1. ○ = R/L

## SPARE PARTS

Holder number	 Clamp screw	 Wrench	 Plug	 Adaptor
EYHC1212D125-IC			Plug-M08-100-05	—
EYHC1212F125-IC				
EYHC1616D160-IC	TS406 (Clamp Torque: 3.5 Nm)	TKY15R		
EYHC1616F160-IC			Plug-G1/8-05	Socket-G1/8
EYHC2020F210-IC				

\* Wrench for Clamp screw

1. ○ = R/L

# MINI-EY

## WITH EXTERNAL COOLANT SUPPLY

### 00° type mono block holder

Insert	GY2M○○○○○○○○○○	-GS	Insert	GY2M○○○○○○○○○○	-GS
		-GM			-GM
Insert	GY2M○○○○○○○○○○	-GU	Insert	GY2M○○○○○○○○○○	-GU
Insert	GY2G○○○○○○○○○○	-MF	Insert	GY2M○○○○○○○○○○R/L○○	-GM

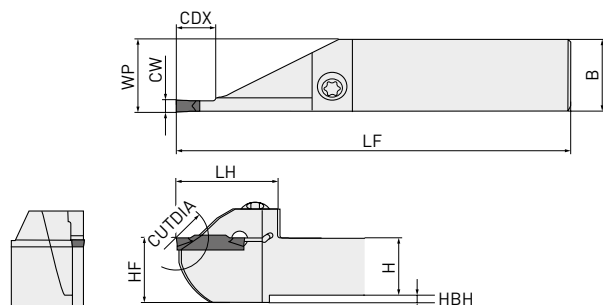

Right hand tool holder shown.

Order number	Stock	Seat size	CW	Hand	CDX	CUTDIA	H	B	LF	LH	HF	HBH
EYHR1212C125	●	C	1.5	R	12.5	25	12	12	110	20	16	4
EYHL1212C125	●			L	12.5	25	12	12	110	20	16	4
EYHR1010D125	●	D	2.0	R	12.5	25	10	10	110	20	14	4
EYHL1010D125	●			L	12.5	25	10	10	110	20	14	4
EYHR1212D125	●	D	2.0	R	12.5	25	12	12	110	20	16	4
EYHL1212D125	●			L	12.5	25	12	12	110	20	16	4
EYHR1212F125	●	F	3.0	R	12.5	25	12	12	110	20	16	4
EYHL1212F125	●			L	12.5	25	12	12	110	20	16	4
EYHR1616C135	●	C	1.5	R	13.5	27	16	16	110	22	16	—
EYHL1616C135	●			L	13.5	27	16	16	110	22	16	—
EYHR1616D160	●	D	2.0	R	16	32	16	16	110	22	16	—
EYHL1616D160	●			L	16	32	16	16	110	22	16	—
EYHR1616F160	●	F	3.0	R	16	32	16	16	110	22	16	—
EYHL1616F160	●			L	16	32	16	16	110	22	16	—

1/1

- When using insert widths 2.39 mm and 2.50 mm with E type seat sizes, in F type holders, the centre height will differ.
- Dimensions shown are when the gauge insert is used. If other insert geometries are used then LF, LH and HF values may vary.



# MINI-EY

## CUTTING MODE AND INSERTS

Holder number	Cutting mode (Right hand holder shown)	Insert Geometry/Insert number
EYHC1212C125		GY2M0300F030N-GU
EYHC1616C135		GY2M0200D020N-GU
EYHC1010D125		GY2M0200D020N-GS
EYHC1212D125		GY2M0300F020N-GS
EYHC1616D160		GY2M0200D020N-GM
EYHC1212F125		GY2M0300F030N-GM
EYHC1616F160		GY2M0200D020R05-GM
		GY2M0200D020L05-GM
	GY2M0300F030R05-GM	 (Gauge insert)
	GY2M0300F030L05-GM	

1. ○ = R/L



## SPARE PARTS

Holder number	 Clamp screw	 Wrench
EYHC1212C125	TS406 (Clamp Torque: 3.5 Nm)	TKY15R
EYHC1616C135		
EYHC1010D125		
EYHC1212D125		
EYHC1616D160		
EYHC1212F125		
EYHC1616F160		

\* Wrench for Clamp screw

1. ○ = R/L

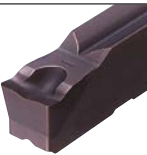
# GY INSERTS

Order number	VP10RT	VP20RT	MY5015	MP9015	MP9025	NX2525	Seat size	Grooving width	Tolerance	RE	CDX	L	Geometry
<b>FOR GROOVING/CUTTING OFF</b>													
GY2M0200D020N-GU	●	●				●	D	2.00	±0.03	0.2	19.7	20.70	GU Breaker (For gummy steel) 
GY2M0239E020N-GU	●	●				●	E	2.39	±0.03	0.2	19.8	20.70	
GY2M0250E020N-GU	●	●				●	E	2.50	±0.03	0.2	19.5	20.70	
GY2M0300F030N-GU	●	●				●	F	3.00	±0.03	0.3	19.3	20.70	
GY2M0318F030N-GU	●	●				●	F	3.18	±0.03	0.3	19.3	20.70	
<b>FOR CUTTING OFF</b>													
GY2M0150C010N-GS	●	●				●	C	1.50	±0.03	0.1	13.4	14.70	GS Breaker (Low feeds) 
GY2M0200D020N-GS	●	●				●	D	2.00	±0.03	0.2	18.7	20.70	
GY2M0239E020N-GS	●	●				●	E	2.39	±0.03	0.2	18.5	20.70	
GY2M0250E020N-GS	●	●				●	E	2.50	±0.03	0.2	18.5	20.70	
GY2M0300F020N-GS	●	●				●	F	3.00	±0.03	0.2	18.5	20.70	
GY2M0318F020N-GS	●	●				●	F	3.18	±0.03	0.2	18.5	20.70	
GY2M0150C020N-GM	●	●	●	●	●	●	C	1.50	±0.03	0.2	13.9	14.70	GM Breaker (Medium feeds) 
GY2M0200D020N-GM	●	●	●	●	●	●	D	2.00	±0.03	0.2	19.4	20.70	
GY2M0239E020N-GM	●	●	●	●	●	●	E	2.39	±0.03	0.2	19.4	20.70	
GY2M0250E020N-GM	●	●	●	●	●	●	E	2.50	±0.03	0.2	19.4	20.70	
GY2M0300F030N-GM	●	●	●	●	●	●	F	3.00	±0.03	0.3	19.4	20.70	
GY2M0318F030N-GM	●	●	●	●	●	●	F	3.18	±0.03	0.3	19.4	20.70	
<b>FOR CUTTING OFF</b>													
GY2M0200D020R05-GM	●	●					D	2.00	±0.03	0.2	19.5	20.80	R/L05-GM Breaker 
GY2M0200D020L05-GM	●	●					D	2.00	±0.03	0.2	19.5	20.80	
GY2M0250E020R05-GM	●	●					E	2.50	±0.03	0.2	19.5	20.825	
GY2M0250E020L05-GM	●	●					E	2.50	±0.03	0.2	19.5	20.825	
GY2M0300F030R05-GM	●	●					F	3.00	±0.03	0.3	19.5	20.85	
GY2M0300F030L05-GM	●	●					F	3.00	±0.03	0.3	19.5	20.85	

Right hand insert shown.

1. When using insert widths 2.39 mm and 2.50 mm with E type seat sizes, in F type holders, the centre height will differ.



# MINI-EY

## RECOMMENDED CUTTING CONDITIONS

Material	Hardness	Grade	Vc	
P	Mild steel	VP20RT	165 (100 – 220)	
		VP10RT	170 (110 – 230)	
		MY5015	220 (140 – 300)	
		NX2525	150 ( 90 – 210)	
	Carbon steel Alloy steel	160 – 280 HB	VP20RT	130 ( 80 – 180)
			VP10RT	140 ( 90 – 190)
			MY5015	180 (110 – 250)
			NX2525	120 ( 70 – 170)
		>280 HB	VP20RT	100 ( 60 – 140)
			VP10RT	110 ( 70 – 150)
			MY5015	100 ( 90 – 210)
			NX2525	95 ( 55 – 135)
M	Stainless steel	<270 HB	VP20RT	100 ( 60 – 140)
		VP10RT	110 ( 70 – 150)	
K	Gray cast iron	Tensile Strength <300 MPa	VP20RT	130 ( 80 – 180)
		VP10RT	280 ( 90 – 190)	
		MY5015	220 (140 – 300)	
	Ductile cast iron	Tensile Strength <800 MPa	VP20RT	100 ( 60 – 140)
		VP10RT	110 ( 70 – 150)	
		MY5015	100 ( 90 – 210)	
S	Heat resistant alloy Titanium alloy	—	VP20RT	45 ( 30 – 60)
		VP10RT	55 ( 40 – 70)	
		MP9015	70 ( 40 – 100)	
		MP9025	60 ( 30 – 90)	

1/1

1. VP20RT is the first recommended grade for materials other than hardened steel.
2. For VP10RT, VP20RT and MY5015, wet cutting is recommended.

# MINI-EY

## RECOMMENDED CUTTING CONDITIONS

### GU Breaker

Grooving, Cutting off

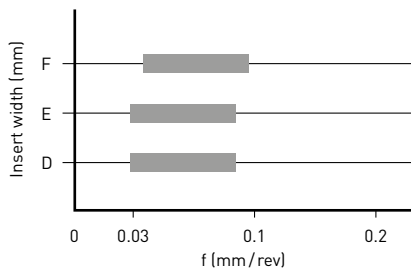

### GS Breaker

Grooving, Cutting off

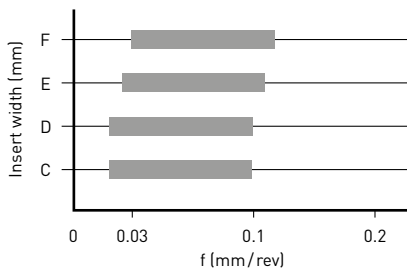

### GM Breaker

Grooving, Cutting off

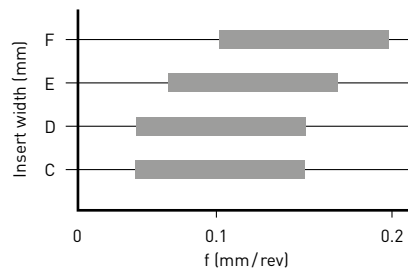

■ : 1st recommended area

Seat size	C	D	E	F
Insert width (mm)	1.50	2.00	2.39	3.00
Insert width (mm)	—	2.24	2.50	3.18
Insert width (mm)	—	—	2.74	3.24

## APPLICATION EXAMPLE

Material	1.4021
Tool	GY2G0300F020N-MF VP20RT
Vc (m/min)	160
f (mm/rev)	0.22
Cutting mode	Semi finishing
Coolant	Internal coolant
Machine	Multi spindle machine MS32

Results Tool life was doubled compared to the conventional tool.

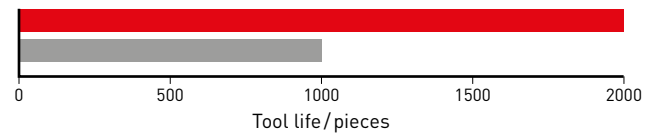

Material	1.4305
Tool	GY2M0200D020N-GM VP20RT
Vc (m/min)	160
f (mm/rev)	0.08/0.04
Cutting mode	Cutting off
Coolant	Internal coolant
Machine	Swiss Type Machine

Results Tool life was doubled compared to the conventional tool.

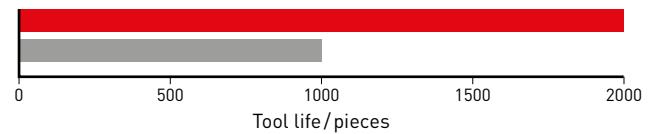

Material	1.4021
Tool	GY2G0300F020N-MF VP20RT
Vc (m/min)	160
f (mm/rev)	0.18/0.07
Cutting mode	Finish cutting
Coolant	Internal coolant
Machine	Multi spindle machine MS32

Results Tool life was 4 times longer than the conventional tool.

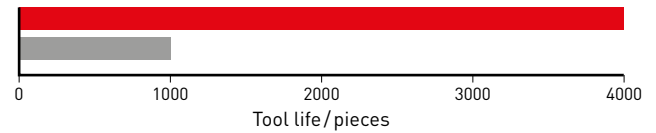

Material	1.4305
Tool	GY2M0200D020N-GM VP20RT
Vc (m/min)	120
f (mm/rev)	0.08/0.04
Cutting mode	Cutting off
Coolant	Internal coolant
Machine	Swiss type machine

Results Tool life was doubled compared to the conventional tool.

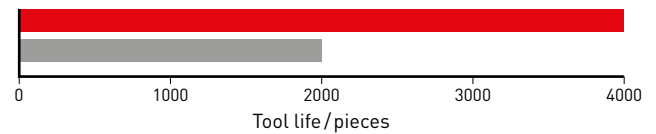

**NEW**

# G80A

PARTING OFF SYSTEM FOR  
TORNOS MULTI-SPINDLE MACHINES

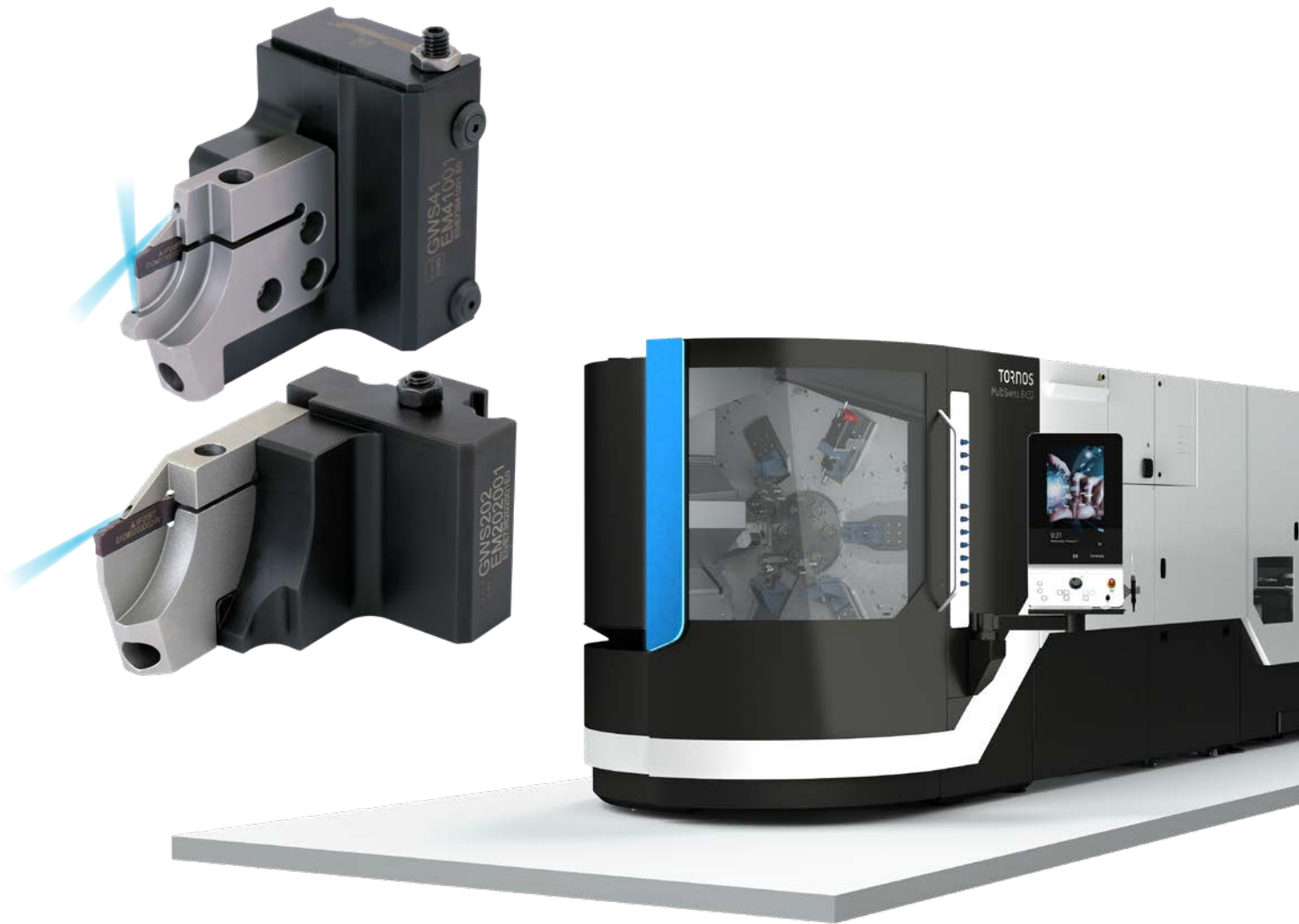

In cooperation with

 **Göltebott**<sup>®</sup>  
Innovation and Precision.

# TORNOS

*Mplus...*

---

# PARTING OFF IN SERIES

---

MODULAR – PERFORMANCE – UNCOMPROMISING

---

Regardless of the industry, it is the deep knowledge of the details that ultimately makes the difference and distinguishes the best from the rest. Whether it is in the medical or automotive industries, general mechanical engineering or the consumer goods industry, the components should be designed using the least space, weight or resources for the same function.

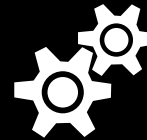
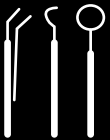

This means, small parts have to be produced in an efficient and precise way, as it has been done for many years on multi-spindle machines. Completely independent of any component details, one of the key elements in the whole machining process is reliable parting off.

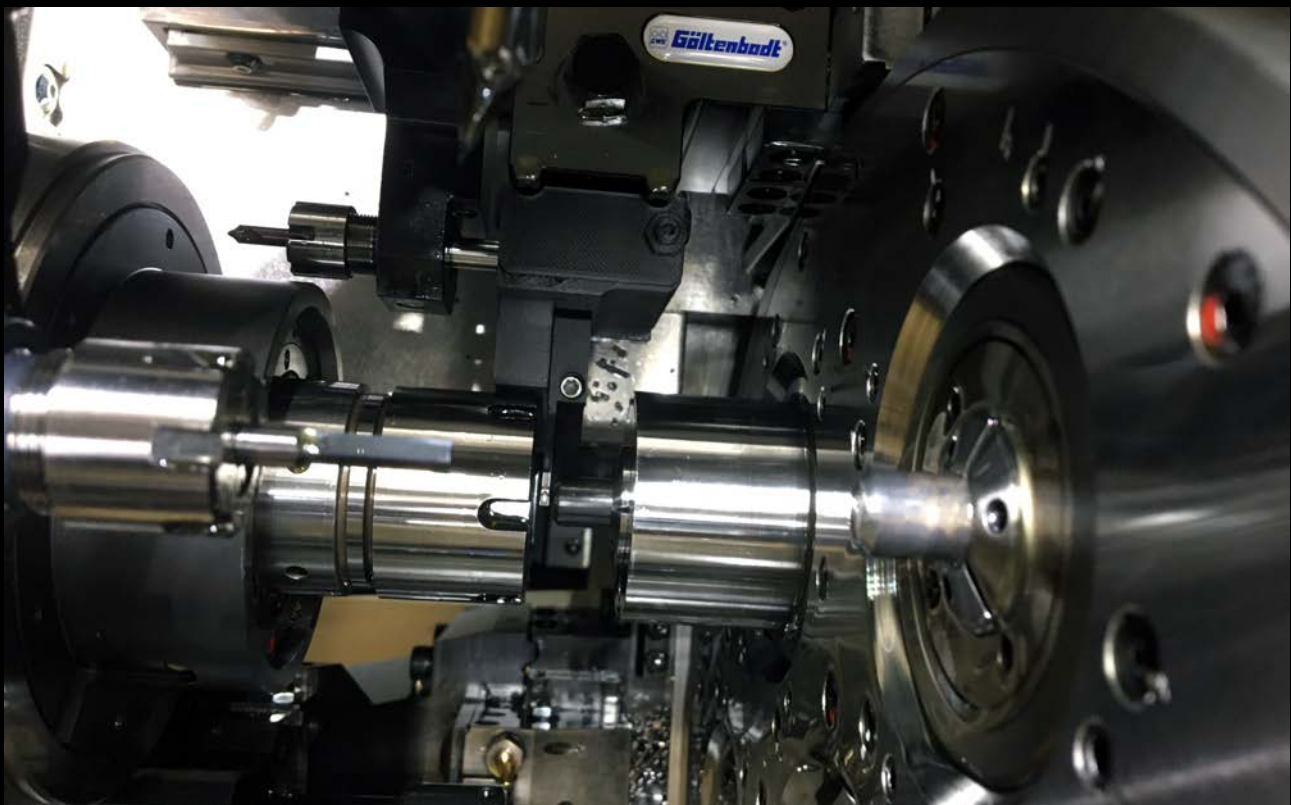

The new G80A parting-off system, also includes the details that offer added performance, reliability and efficiency. The targeted internal coolant supply makes the process even more reliable and enables longer tool life.

Easy handling both when changing inserts and when setting the centre height are added features. The grooving modules are specially designed for the conditions on the machine, which significantly increases stability.



# PARTING OFF SYSTEM FOR TORNOS MULTI-SPINDLE MACHINES

## FOR THE LIMITED SPACE IN MULTI-SPINDLE MACHINES

Reliable parting off with modular tools specially designed for Swiss multi-spindle machines in cooperation with Göltentbodt. Efficient and reliable processing is realised due to the optimized internal through coolant supply for parting off widths from 1.5 mm.

### Product range

- Quick change adapter system GWS41
- Quick change adapter system GWS202
- Modules for GY indexable inserts
- GY indexable inserts

### Characteristics

- Designed for the limited space between the main and counter spindle
- Secure and accurate clamping of the indexable insert
- Optimised through coolant supply



SPECIALLY DESIGNED FEATURES FOR

EFFICIENCY AND EASE OF USE



### BENEFITS

- High process reliability
- Internal coolant supply optimised for long tool life
- Small grooving width for maximum material utilisation



# G80A

## PARTING OFF SYSTEM FOR TORNOS MULTI-SPINDLE MACHINES

Internal coolant supply up to 8 Mpa for optimal coolant on the cutting edge.

Stability based on the proven Göltenbodt GWS column guide system. Quick change, easy centre height setting and precision in one system.

Accessible and strong clamping of the indexable insert.

Optimal stability and function by individual alignment of the components and with regards to the limited space in these type of machines.



# G80A

## PARTING OFF SYSTEM FOR TORNOS MULTI-SPINDLE MACHINES

Designed respectively for the current Tornos Multi-Swiss machines the following combinations are available.



Göthenbodt system GWS41 (page 8+7)

Göthenbodt system GWS202 (page 9+9)



Modul G80A w = 1.5 - w = 2.0

Modul G80A w = 2.0



Wide variety of GY-grooving inserts for applications in different materials

# G80A

## QUICK CHANGE TYPE ADAPTERS GWS41

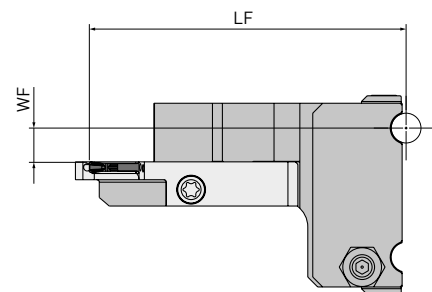
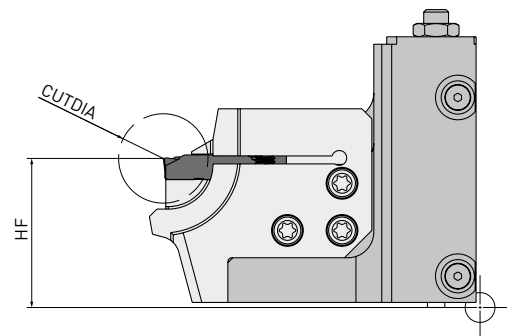

Order number	Stock	Hand	GWS system	Suitable for machine	CUTDIA	LF X-Axis	HF Y-Axis	WF Z-Axis
EM41001	●	R	41	MS 6x16	16	63.8*	30	7.15 (cw = 1.5) / 6.9 (cw = 2.0)

1/1

1. Module shown only for dimensional visualisation.  
\* Spindle nut diameter max. 30 mm.

**Göltebott**  
Innovation and Precision.

# G80A

## MODULE FOR QUICK CHANGE ADAPTER GWS41

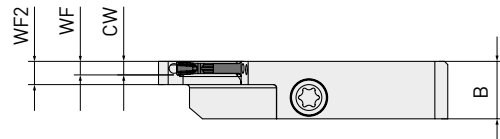
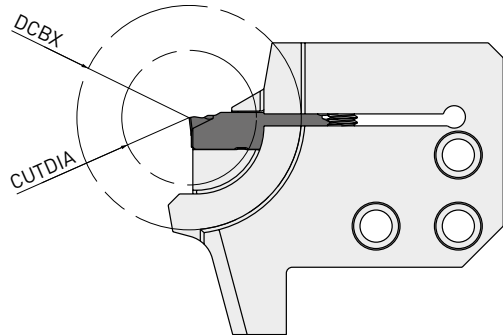



Order number	Stock	Hand	GWS system	Suitable for machine	CUTDIA	DCBX	Seat size	CW	WF	WF2	B	IK
G80A-EM410RL16GYC2-E	●	R	41	MS 6 x 16	16	30	C	1.5	1.85	3.6	8.9	FF1 / SF2
G80A-EM410RL16GYD2-E	●	R	41	MS 6 x 16	16	30	D	2.0	2.1	3.6	8.9	FF1 / SF2

1/1

1. For modules with flank cooling (FF), tool presetting must be carried out using the incident light method.
2. Rake face coolant requires no specific presetting method.



## SPARE PARTS

Tool holder	 Screw	 Wrench
EM41001	TS43 [3.5 Nm]*	
G80A-EM410RL16GYC2-E		TKY15W-E
G80A-EM410RL16GYD2-E	TS406 [3.5 Nm]*	

\* Recommended to use a torque screwdriver with a Torx 15 bit.



# G80A

## QUICK CHANGE ADAPTERS GWS202

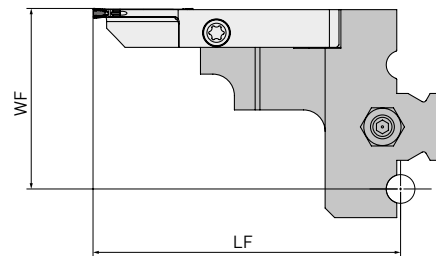
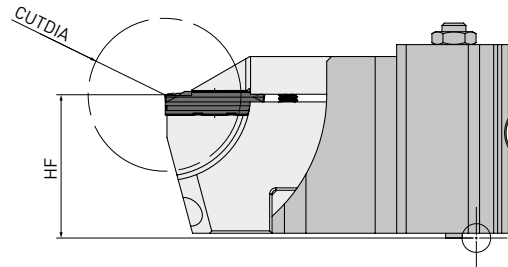

Order number	Stock	Hand	GWS system	Suitable for machine	CUTDIA	LF X-Axis	HF Y-Axis	WF Z-Axis
EM202001	●	L	202	MS 8x26 / MS 6x32	32*	64.4	30	37.8 (cw = 2.0)

1/1

1. Module shown only for dimensional visualisation.  
 \* Spindle nut diameter max. 66 mm.

**Göltebodt**  
 Innovation and Precision.

# G80A

## MODULE FOR QUICK CHANGE ADAPTER GWS202

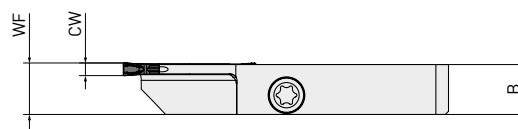
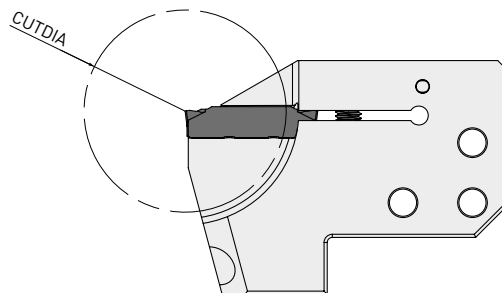



Order number	Stock	Hand	GWS system	Suitable for machine	CUTDIA	Seat size	CW	WF	B	IK
G80A-EM202LL32GYD1-E	●	L	41	MS 8 x 26 / MS 6 x 32	32	D	2.0	8.15	7.9	SF1

1/1

1. Rake face coolant requires no specific presetting method.



## SPARE PARTS

Tool holder		
	Screw	Wrench
EM202001	TS43 (3.5 Nm)*	TKY15W-E
G80A-EM202LL32GYD1-E	TS406 (3.5 Nm)*	

\* Recommended to use a torque screwdriver with a Torx 15 bit.

# G80A

## PERFORMANCE COMPARISON 1

Material	NiCr23Fe
Tool	GWS41 – G80A
Vc (m/min)	47
f (mm/rev)	0.02
Lot size	20.000.000
Efficiency increase	Approx. 55.000 €/batch tooling cost reduction
Results	10.000 m less material consumption due to smaller grooving width.

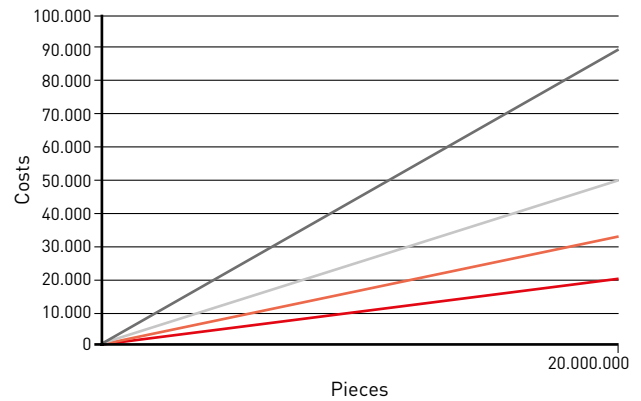

## PERFORMANCE COMPARISON 2

Material	100Cr6
Tool	GWS41 – G80A
Vc (m/min)	117
f (mm/rev)	0.03
Lot size	50.000
Efficiency increase	Approx. 430 €/Lot
Results	Positive environmental influence enabled by producing less scrap material.

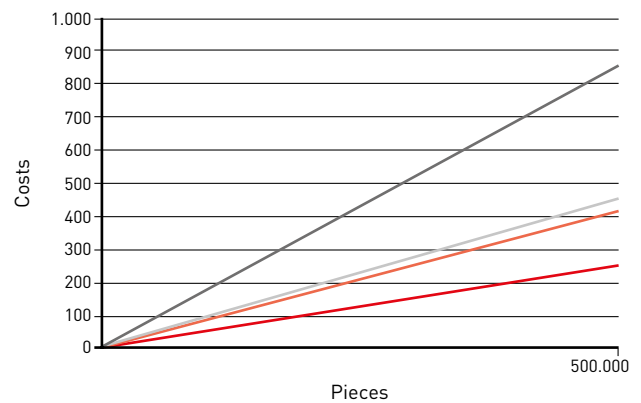

# G80A

## SPECIAL SOLUTIONS

Not all types of machines are mentioned in the overview on page 21. Technical support regarding fitment of the G80A type tool or a custom solution can be offered for other types of machines.

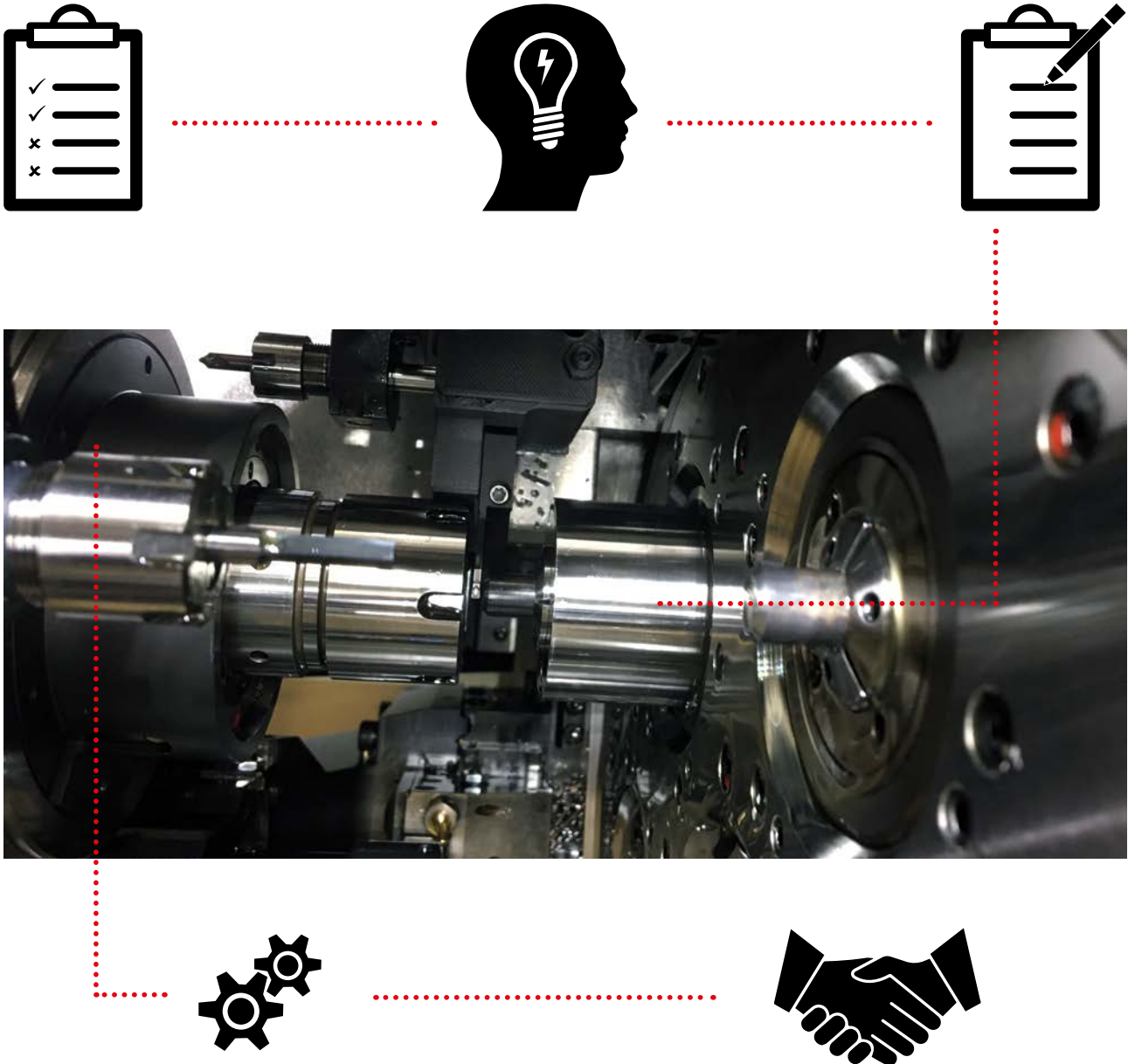

Please contact the local Mitsubishi Materials supplier for special analysis of the situation. If a tailored solution is required, collision tests are carried out both using CAD and on site using an additively manufactured tool model before the final tool is produced. After successful testing, a final solution will be offered.

# G80A

## GY-GROOVING INSERTS

### INSERT GRADES

P	M	K	S	N
NX2525 ●				
MY5015 ●		MY5015 ●	MP9015 ●	
VP10RT ●	VP10RT ●	VP10RT ●	MP9025 ●	RT9020 ●
VP20RT ❄	VP20RT ❄	VP20RT ❄		RT9020 ●

### MP9000 SERIES

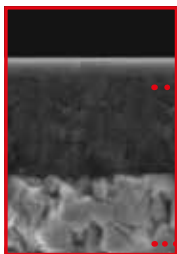

The high Al-rich (Al, Ti)N single layer coating provides stabilization of the high hardness phase and succeeds in dramatically improving wear, crater and welding resistance.

..... High Al-rich (Al, Ti)N Single Layer Coating

..... Special Cemented Carbide Substrate

### MY5015

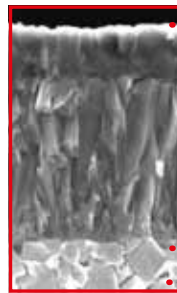

CVD coated grade with excellent wear resistance even at high temperatures. Providing longer tool life when machining cast and ductile cast irons. Also suitable for high speed continuous cutting of steels.

..... CVD coating

..... Carbide substrate

### VP20RT

**(1<sup>st</sup> Recommendation)**



PVD coated grade suitable for a wide range of applications. The combination of a special tough cemented carbide substrate with MIRACLE coating provides an excellent balance of wear and fracture resistance.

..... MIRACLE coating

..... Carbide substrate (HRA90.5)

### RT9010

First recommended grade for titanium alloys.

### NX2525

NX2525, a cermet grade for finish machining of steels and for good surface finishes at lower cutting speeds.

### VP10RT

**(2<sup>nd</sup> Recommendation)**

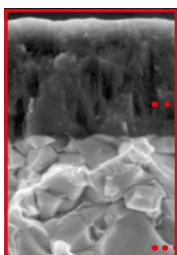

PVD coated grade with a cemented carbide substrate harder than VP20RT. For use on difficult-to-cut materials and for extending tool life.





..... MIRACLE coating

..... Carbide substrate (HRA92.0)

# G80A

## A WIDE SELECTION OF INSERTS

### PARTING OFF

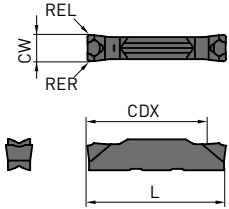
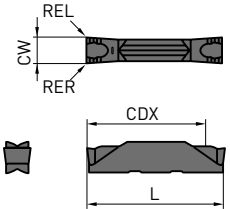
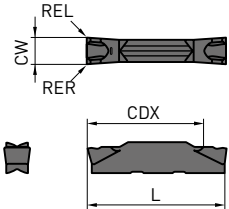
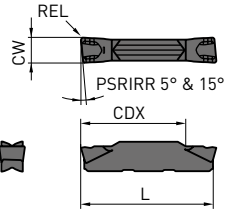
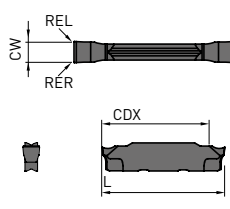
GU Chipbreaker (For mild steel)	GS Chipbreaker (Low feeds)	GM Chipbreaker (Medium feeds)	R/L05-/R15-GS- GM Breaker (Medium feeds)	GL Breaker (For aluminium alloys)
				
				

Right hand tool holder shown.

### GROOVING / CUTTING OFF

Order number	RT9010	VP10RT	VP20RT	MY5015	NX2525	MP9015	MP9025	Seat size	CW	Tolerance	RE R/L	CDX	L
GY2M0200D020N-GU		●	●		●			D	2.00	±0.03	0.2	19.7	20.70
GY2M0150C010N-GS		●	●					C	1.50	±0.03	0.1	13.4	14.70
GY2G0150C003R15-GS		●	●					C	1.50	±0.02	0.03	13.17	15.20
GY2G0150C010R08-GS		●	●					C	1.50	±0.02	0.1	13.17	15.20
GY2G0150C010R15-GS		●	●					C	1.50	±0.02	0.1	13.17	15.20
GY2M0200D020N-GS		●	●		●			D	2.00	±0.03	0.2	18.7	20.70
GY2G0200D003R15-GS		●	●					D	2.00	±0.03	0.03	18.85	21.30
GY2G0200D010R15-GS		●	●					D	2.00	±0.03	0.1	18.85	21.30
GY2G0200D020R08-GS		●	●					D	2.00	±0.03	0.2	18.85	21.30
GY2M0150C020N-GM		●	●		●	●	●	C	1.50	±0.03	0.2	13.9	14.70
GY2M0200D020N-GM		●	●	●	●	●	●	D	2.00	±0.03	0.2	19.4	20.70
GY2M0200D020R05-GM		●	●					D	2.00	±0.03	0.2	19.5	20.80
GY2M0200D020L05-GM		●	●					D	2.00	±0.03	0.2	19.5	20.80
GY1M0200D020L05-GM		★	●					D	2.00	±0.03	0.2	—	20.80
GY1M0200D020N-GM		●	●	●		●	●	D	2.00	±0.03	0.2	—	20.70
GY1M0200D020R05-GM		●	●					D	2.00	±0.03	0.2	—	20.80
GY2G0200D005N-GL	●							D	2.00	±0.02	0.05	19.5	21.05

1/1



# G80A

## RECOMMENDED CUTTING CONDITIONS

Material	Hardness	Grade	Vc	
P	Mild steel	VP20RT	160 (100 – 220)	
		VP10RT	170 (110 – 230)	
		MY5015	220 (140 – 300)	
		NX2525	150 ( 90 – 210)	
	Carbon steel Alloy steel	160 – 280HB	VP20RT	130 ( 80 – 180)
			VP10RT	140 ( 90 – 190)
			MY5015	180 (110 – 250)
			NX2525	120 ( 70 – 170)
		≥280HB	VP20RT	100 ( 60 – 140)
			VP10RT	110 ( 70 – 150)
			MY5015	150 ( 90 – 210)
			NX2525	95 ( 55 – 135)
M	Stainless steel	VP20RT	100 ( 60 – 140)	
		VP10RT	110 ( 70 – 150)	
K	Gray cast iron	VP20RT	130 ( 80 – 180)	
		VP10RT	140 ( 90 – 190)	
		MY5015	220 (140 – 300)	
	Ductile cast iron	VP20RT	100 ( 60 – 140)	
		VP10RT	110 ( 70 – 150)	
		MY5015	150 ( 90 – 210)	
S	Heat resistant alloy Titanium alloy	MP9015	70 ( 40 – 100)	
		MP9025	60 ( 30 – 90)	
		VP20RT	45 ( 30 – 60)	
		VP10RT	55 ( 40 – 70)	

1/1

1. **VP20RT** is the first recommended grade for materials other than hardened steel.
2. For VP10RT, VP20RT, MP9015, MP9025 and MY5015, wet cutting is recommended.

## RECOMMENDED FEED RATE (MM/REV)

CW	Breaker			
	GU	GS	GM	GL
1.5	—	0.025 – 0.130	0.05 – 0.15	—
2.0	0.03 – 0.08	0.025 – 0.130	0.05 – 0.15	0.02 – 0.08

---

# ISO PSC TOOL HOLDERS

---

WIDE RANGE OF PSC HOLDERS  
FOR MULTIPLE APPLICATIONS

---



*M*plus...



# ISO PSC TOOL HOLDERS

## WIDE RANGE PSC HOLDERS FOR MULTIPLE OPERATIONS

The new ISO PSC Holder series is taking advantage of the latest technology, materials and geometries. Due to the wide variety of tools available, this series offers a solution for nearly every application – ranging from multi-purpose, through to turning, milling and profiling tool holders and boring bars.

### PRODUCT RANGE

- D-Type Holder
- P-Type Holder
- S-Type Holder
- P-Type Boring Bar
- S-Type Boring Bar
- External and internal threading
- Top clamp holder for ceramic inserts

### AVAILABILITY

- All turning applications

### FEATURES

- High fracture resistance
- Stable cutting and burr prevention
- Internal coolant supply
- Stable insert clamping
- Highly wear resistant body



**OPTIMISATION OF TOOL LIFE**

**BETTER SURFACE FINISHES**

**HIGHER PROCESS RELIABILITY**

**INCREASED PRODUCTIVITY**



### BENEFITS

- Optimisation of tool life
- Better surface finishes
- Higher process reliability
- Increased productivity



## ISO PSC TOOL HOLDERS

---

ISO PSC Holder with through coolant to the cutting edge for optimum cooling, chip evacuation and long tool life.

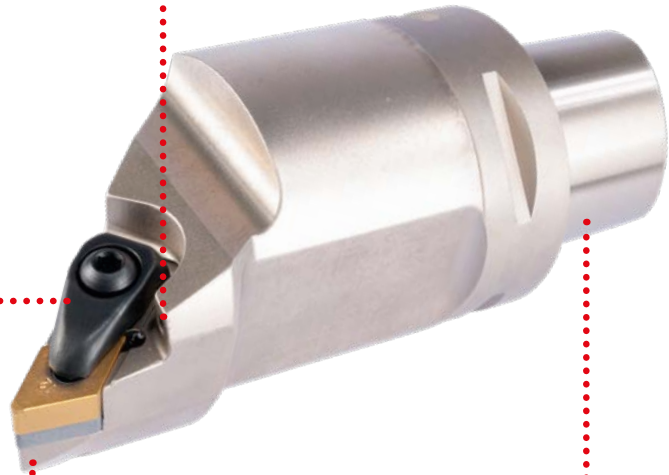

Stable clamping.

High strength tool body material and coating for long tool life.



The polygonal shape of ISO PSC Holder ensures stable clamping and perfect positioning and also prevents torsional movement or deflection.

# INDEX

Product code		Product code	
DCKN 75°	35	SDJC 93°	57
DCLN 95°	36	SDNC 62° 30`	58
DCMN 50°	38	SVHC 107° 30`	59
DCRN 75°	39	SVJC 93°	60
DDHN 107° 30`	40	SVVC 72° 30`	61
DDJN 93°	41	PCLN 95°	62
DDMN 48°	42	PDUN 93°	64
DSDN 45°	43	SCLC 95°	66
DSSN 45°	44	SDUC 93°	68
DVJN 93°	45	SVQC 107° 30`	70
DVVN 72° 30`	46	External threading 90°	71
DWLN 95°	47	Internal threading 90°	72
PCLN 95°	48	CRSN	76
PCRN 75°	50	MA-Type adaptor	77
PDJN 93°	51	MS-Type screwed shank	78
PSDN 45°	52	B-Type boring bar holder	79
PSKN 75°	53	C-Type collet chucks	81
PSRN 75°	54	TA-Type adaptor	83
PSSN 45°	55	TR-Type adaptor	84
SCLC 95°	56	AC-Type caps	85

**NOTES:** We reserve the right to make changes to any item compared to the information and illustrations shown in this catalogue, e.g. with regard to technical data, construction, equipment provided, material and external appearance. All dimensions are in millimetres. You will find the latest version of this catalogue on our microsite: [europe.mmc-carbide.com](http://europe.mmc-carbide.com)

# DCKN 75°

## MULTI-PURPOSE TOOL HOLDER EQUIPPED WITH RHOMBIC NEGATIVE DOUBLE-SIDED INSERTS





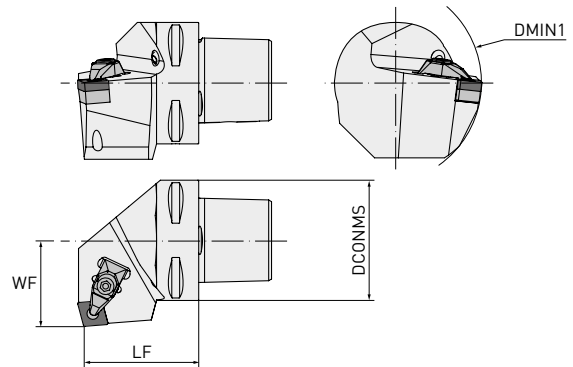



GAMF:  $-6^\circ$   
GAMP:  $-6^\circ$



Order number	Stock	Hand	DCONMS	DMIN1	LF	WF	WT	Insert
PSC40-DCKNL27050-12	<input type="checkbox"/>	L	40	110	50	27	0.42	
PSC40-DCKNR27050-12	<input checked="" type="checkbox"/>	R	40	110	50	27	0.42	
PSC50-DCKNL35060-12	<input type="checkbox"/>	L	50	110	60	35	0.80	CN00120400
PSC50-DCKNR35060-12	<input type="checkbox"/>	R	50	110	60	35	0.80	
PSC63-DCKNL45065-12	<input type="checkbox"/>	L	63	110	65	45	1.10	
PSC63-DCKNR45065-12	<input type="checkbox"/>	R	63	110	65	45	1.10	
PSC63-DCKNL45065-16	<input checked="" type="checkbox"/>	L	63	125	65	45	1.10	CN00160600
PSC63-DCKNR45065-16	<input checked="" type="checkbox"/>	R	63	125	65	45	1.10	
PSC80-DCKNL55080-19	<input checked="" type="checkbox"/>	L	80	125	80	55	2.74	CN00190600
PSC80-DCKNR55080-19	<input checked="" type="checkbox"/>	R	80	125	80	55	2.74	

1/1

## SPARE PARTS

Tool holder type						
PSC40-DCKNL27050-12	MP1766	MPICSN-442	MP2712			
PSC40-DCKNR27050-12	MP1766	MPICSN-442	MP2712			
PSC50-DCKNL35060-12	MP1766	MPICSN-442	MP2712			
PSC50-DCKNR35060-12	MP1766	MPICSN-442	MP2712			
PSC63-DCKNL45065-12	MP1766	MPICSN-442	MP2712			
PSC63-DCKNR45065-12	MP1766	MPICSN-442	MP2712	MP1696	MP4295	MP5004
PSC63-DCKNL45065-16	MP1768	MPICSN-533	MP2716			
PSC63-DCKNR45065-16	MP1768	MPICSN-533	MP2716			
PSC80-DCKNL55080-19	MP1770	MPICSN-633	MP2719			
PSC80-DCKNR55080-19	MP1770	MPICSN-633	MP2719			

# DCLN 95°

## MULTI-PURPOSE TOOL HOLDER EQUIPPED WITH RHOMBIC NEGATIVE DOUBLE-SIDED INSERTS



GAMF:  $-6^\circ$   
GAMP:  $-6^\circ$

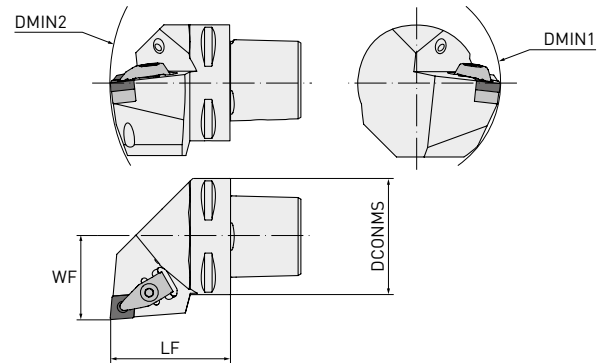







Order number	Stock	Hand	DCONMS	DMIN1	DMIN2	LF	WF	WT	Insert
PSC40-DCLNL27050-12	●	L	40	110	140	50	27	0.42	
PSC40-DCLNR27050-12	●	R	40	110	110	50	27	0.42	
PSC50-DCLNL35060-12	●	L	50	110	165	60	35	0.80	
PSC50-DCLNR35060-12	●	R	50	110	165	60	35	0.80	CN00120400
PSC63-DCLNL45065-12	●	L	63	110	190	65	45	1.10	
PSC63-DCLNR45065-12	●	R	63	110	190	65	45	1.10	
PSC80-DCLNL55080-12	●	L	80	110	250	80	55	2.74	
PSC80-DCLNR55080-12	●	R	80	110	250	80	55	2.74	
PSC50-DCLNL35060-16	●	L	50	125	165	60	35	0.80	
PSC50-DCLNR35060-16	●	R	50	125	165	60	35	0.80	
PSC63-DCLNL45065-16	●	L	63	125	190	65	45	1.10	
PSC63-DCLNR45065-16	●	R	63	125	190	65	45	1.10	CN00160600
PSC80-DCLNL55080-16	●	L	80	125	250	80	55	2.74	
PSC80-DCLNR55080-16	●	R	80	125	250	80	55	2.74	
PSC63-DCLNL45065-19	●	L	63	125	190	65	45	1.10	
PSC63-DCLNR45065-19	●	R	63	125	190	65	45	1.10	
PSC80-DCLNL55080-19	●	L	80	125	250	80	55	2.74	CN00190600
PSC80-DCLNR55080-19	●	R	80	125	250	80	55	2.74	

1/1

DCLN 95°

## SPARE PARTS

Tool holder type						
PSC40-DCLNL27050-12	MP1766	MPICSN-442	MP2712			
PSC40-DCLNR27050-12	MP1766	MPICSN-442	MP2712			
PSC50-DCLNL35060-12	MP1766	MPICSN-442	MP2712			
PSC50-DCLNR35060-12	MP1766	MPICSN-442	MP2712			
PSC63-DCLNL45065-12	MP1766	MPICSN-442	MP2712			
PSC63-DCLNR45065-12	MP1766	MPICSN-442	MP2712			
PSC80-DCLNL55080-12	MP1766	MPICSN-442	MP2712			
PSC80-DCLNR55080-12	MP1766	MPICSN-442	MP2712			
PSC50-DCLNL35060-16	MP1768	MPICSN-533	MP2716	MP1696	MP4295	MP5004
PSC50-DCLNR35060-16	MP1768	MPICSN-533	MP2716			
PSC63-DCLNL45065-16	MP1768	MPICSN-533	MP2716			
PSC63-DCLNR45065-16	MP1768	MPICSN-533	MP2716			
PSC80-DCLNL55080-16	MP1768	MPICSN-533	MP2716			
PSC80-DCLNR55080-16	MP1768	MPICSN-533	MP2716			
PSC63-DCLNL45065-19	MP1770	MPICSN-633	MP2719			
PSC63-DCLNR45065-19	MP1770	MPICSN-633	MP2719			
PSC80-DCLNL55080-19	MP1770	MPICSN-633	MP2719			
PSC80-DCLNR55080-19	MP1770	MPICSN-633	MP2719			

# DCMNN 50°

TOOL HOLDER FOR MULTI-TASK MACHINING EQUIPPED WITH RHOMBIC NEGATIVE DOUBLE-SIDED INSERTS



GAMF:  $-6^\circ$   
GAMP:  $-6^\circ$

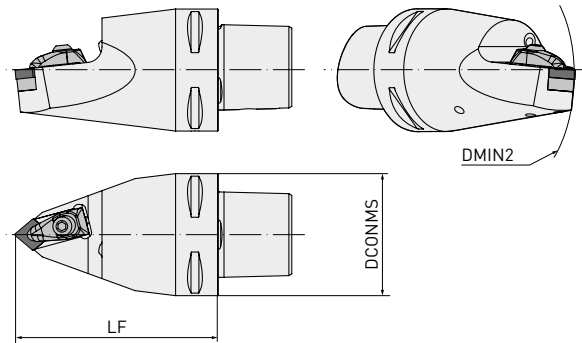

Order number	Stock	DCONMS	DMIN2	LF	WT	Insert
PSC63-DCMNN00115-12	●	63	110	115	1.7	CN00120400
PSC80-DCMNN00150-16	●	80	115	150	3.3	CN00160600

1/1

## SPARE PARTS

Tool holder type



PSC63-DCMNN00115-12	MP1766	MPICSN-442	MP2712	MP1696	MP4295	MP5004
PSC80-DCMNN00150-16	MP1768	MPICSN-533	MP2716			

# DCRN 75°

## MULTI-PURPOSE TOOL HOLDER EQUIPPED WITH RHOMBIC NEGATIVE DOUBLE-SIDED INSERTS





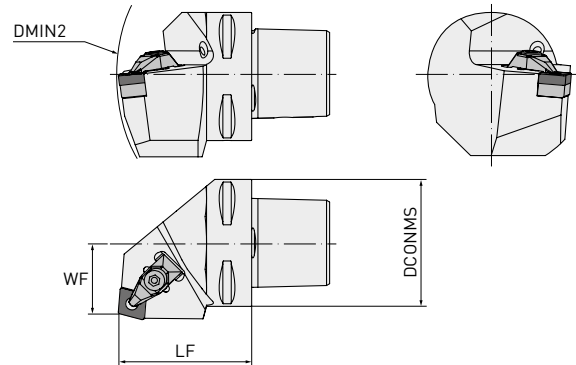



GAMF:  $-6^\circ$   
GAMP:  $-6^\circ$



Order number	Stock	Hand	DCONMS	DMIN2	WF	LF	WT	Insert
PSC50-DCRNL27060-12	<input type="checkbox"/>	L	50	165	27	60	0.80	CN00120400
PSC50-DCRNR27060-12	<input type="checkbox"/>	R	50	165	27	60	0.80	
PSC63-DCRNL35065-12	<input type="checkbox"/>	L	63	190	35	65	1.40	
PSC63-DCRNR35065-12	<input type="checkbox"/>	R	63	190	35	65	1.40	
PSC63-DCRNL35065-16	<input checked="" type="checkbox"/>	L	63	190	35	65	1.40	CN00160600
PSC63-DCRNR35065-16	<input type="checkbox"/>	R	63	190	35	65	1.40	
PSC80-DCRNL55080-16	<input checked="" type="checkbox"/>	L	80	250	55	80	2.74	
PSC80-DCRNR55080-16	<input type="checkbox"/>	R	80	250	55	80	2.74	
PSC63-DCRNL35065-19	<input checked="" type="checkbox"/>	L	63	190	35	65	1.40	CN00190600
PSC63-DCRNR35065-19	<input checked="" type="checkbox"/>	R	63	190	35	65	1.40	
PSC80-DCRNL55080-19	<input checked="" type="checkbox"/>	L	80	250	55	80	2.74	
PSC80-DCRNR55080-19	<input checked="" type="checkbox"/>	R	80	250	55	80	2.74	

1/1

## SPARE PARTS

Tool holder type						
PSC50-DCRNL27060-12	MP1766	MPICSN-442	MP2712			
PSC50-DCRNR27060-12	MP1766	MPICSN-442	MP2712			
PSC63-DCRNL35065-12	MP1766	MPICSN-442	MP2712			
PSC63-DCRNR35065-12	MP1766	MPICSN-442	MP2712			
PSC63-DCRNL35065-16	MP1768	MPICSN-533	MP2716			
PSC63-DCRNR35065-16	MP1768	MPICSN-533	MP2716	MP1696	MP4295	MP5004
PSC80-DCRNL55080-16	MP1768	MPICSN-533	MP2716			
PSC80-DCRNR55080-16	MP1768	MPICSN-533	MP2716			
PSC63-DCRNL35065-19	MP1770	MPICSN-633	MP2719			
PSC63-DCRNR35065-19	MP1770	MPICSN-633	MP2719			
PSC80-DCRNL55080-19	MP1770	MPICSN-633	MP2719			
PSC80-DCRNR55080-19	MP1770	MPICSN-633	MP2719			



# DDHN 107° 30'

## TURNING AND PROFILING TOOL HOLDER EQUIPPED WITH RHOMBIC NEGATIVE DOUBLE-SIDED INSERTS



GAMF:  $-6^\circ$   
GAMP:  $-7^\circ$

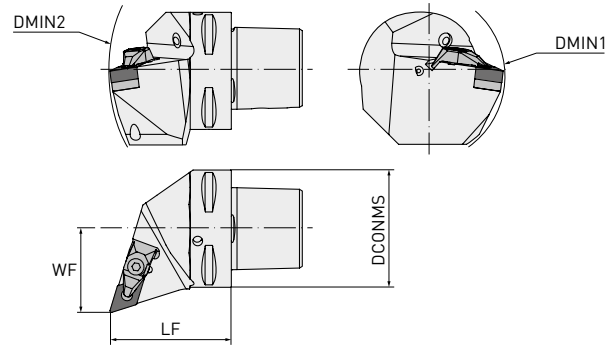

Order number	Stock	Hand	DCONMS	DMIN1	DMIN2	WF	LF	WT	Insert
PSC40-DDHNL27055-15	●	L	40	110	145	27	55	0.43	DN00150600
PSC40-DDHNR27055-15	□	R	40	110	145	27	55	0.43	
PSC50-DDHNL35060-15	●	L	50	110	165	35	60	0.80	
PSC50-DDHNR35060-15	●	R	50	110	165	35	60	0.80	
PSC63-DDHNL45065-15	●	L	63	110	190	45	65	1.10	
PSC63-DDHNR45065-15	●	R	63	110	190	45	65	1.10	
PSC80-DDHNL55080-15	●	L	80	110	250	55	80	2.74	
PSC80-DDHNR55080-15	●	R	80	110	250	55	80	2.74	

1/1

## SPARE PARTS

### Tool holder type



PSC40-DDHNL27055-15						
PSC40-DDHNR27055-15						
PSC50-DDHNL35060-15						
PSC50-DDHNR35060-15	MP1766	MPIDSN-432	MP2712	MP1696	MP4295	MP5004
PSC63-DDHNL45065-15						
PSC63-DDHNR45065-15						
PSC80-DDHNL55080-15						
PSC80-DDHNR55080-15						

# DDJN 93°

## TURNING AND PROFILING TOOL HOLDER EQUIPPED WITH RHOMBIC NEGATIVE DOUBLE-SIDED INSERTS





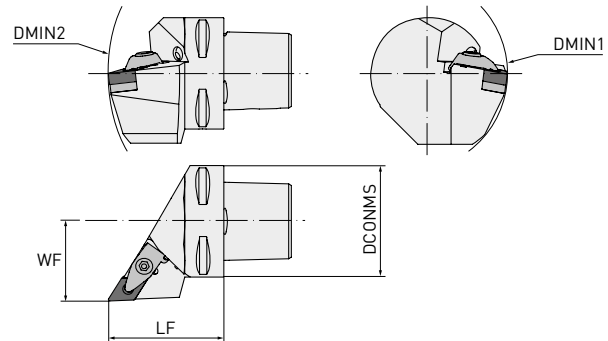



GAMF:  $-6^\circ$   
GAMP:  $-7^\circ$



Order number	Stock	Hand	DCONMS	DMIN1	DMIN2	WF	LF	WT	Insert
PSC40-DDJNL27050-11	●	L	40	60	140	27	50	0.42	DN $\odot$ 1104 $\odot\odot$
PSC40-DDJNR27050-11	●	R	40	60	140	27	50	0.42	
PSC40-DDJNL27055-15	●	L	40	110	145	27	55	0.42	DN $\odot$ 1506 $\odot\odot$
PSC40-DDJNR27055-15	●	R	40	110	145	27	55	1.10	
PSC50-DDJNL35060-11	●	L	50	65	165	35	60	0.80	DN $\odot$ 1104 $\odot\odot$
PSC50-DDJNR35060-11	●	R	50	65	165	35	60	0.80	
PSC50-DDJNL35060-15	●	L	50	110	165	35	60	0.80	DN $\odot$ 1506 $\odot\odot$
PSC50-DDJNR35060-15	●	R	50	110	165	35	60	0.80	
PSC63-DDJNL45065-15	●	L	63	110	190	45	65	1.10	DN $\odot$ 1506 $\odot\odot$
PSC63-DDJNR45065-15	●	R	63	110	190	45	65	1.10	
PSC80-DDJNL55080-15	●	L	80	110	250	55	80	2.74	DN $\odot$ 1506 $\odot\odot$
PSC80-DDJNR55080-15	●	R	80	110	250	55	80	2.74	

1/1

## SPARE PARTS

Tool holder type						
PSC40-DDJNL27050-11	MP1764	MPIDSN-322	MP2708	MP1695	MP4294	MP5004
PSC40-DDJNR27050-11	MP1764	MPIDSN-322	MP2708	MP1695	MP4294	
PSC40-DDJNL27055-15	MP1766	MPIDSN-432	MP2712	MP1696	MP4295	
PSC40-DDJNR27055-15	MP1766	MPIDSN-432	MP2712	MP1696	MP4295	
PSC50-DDJNL35060-11	MP1764	MPIDSN-322	MP2708	MP1695	MP4294	
PSC50-DDJNR35060-11	MP1764	MPIDSN-322	MP2708	MP1695	MP4294	
PSC50-DDJNL35060-15	MP1766	MPIDSN-432	MP2712	MP1696	MP4295	
PSC50-DDJNR35060-15	MP1766	MPIDSN-432	MP2712	MP1696	MP4295	
PSC63-DDJNL45065-15	MP1766	MPIDSN-432	MP2712	MP1696	MP4295	
PSC63-DDJNR45065-15	MP1766	MPIDSN-432	MP2712	MP1696	MP4295	
PSC80-DDJNL55080-15	MP1766	MPIDSN-432	MP2712	MP1696	MP4295	
PSC80-DDJNR55080-15	MP1766	MPIDSN-432	MP2712	MP1696	MP4295	

● : Inventory maintained.

# DDMN 48°

TOOL HOLDER FOR MULTI-TASK MACHINING EQUIPPED WITH RHOMBIC NEGATIVE DOUBLE-SIDED INSERTS



GAMF: -5°  
GAMP: -9°

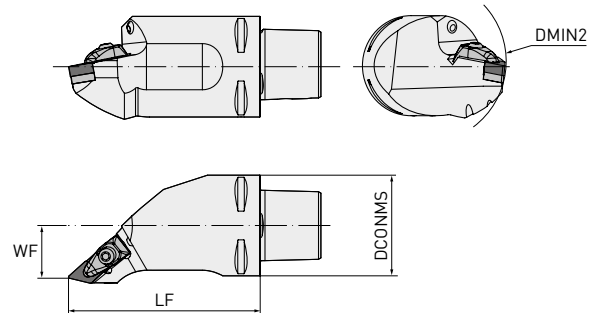

Order number	Stock	Hand	DCONMS	DMIN1	DMIN2	WF	LF	WT	Insert
PSC63-DDMNL33120-15	●	L	63	63	130	33	120	2.30	DN $\odot$ 1506 $\odot\odot$
PSC63-DDMNR33120-15	●	R							

1/1

## SPARE PARTS

Tool holder type



PSC63-DDMNL33120-15

MP1766

MPIDSN-432

MP2712

MP1696

MP4295

MP5004

PSC63-DDMNR33120-15

# DSDN 45°

TOOL HOLDER FOR EXTERNAL TURNING AND CHAMFERING  
EQUIPPED WITH SQUARE NEGATIVE DOUBLE-SIDED INSERTS

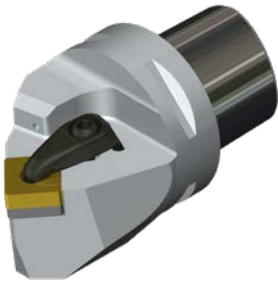



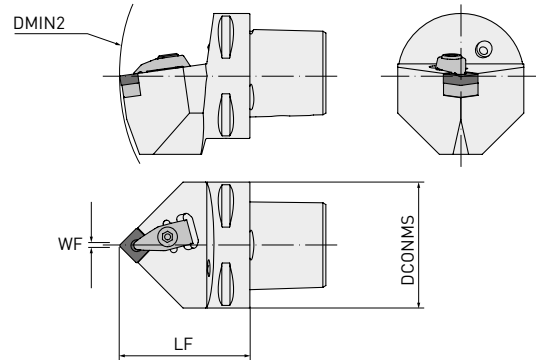



GAMF:  $-6^\circ$   
GAMP:  $-6^\circ$



Order number	Stock	DCONMS	DMIN2	WF	LF	WT	Insert
PSC40-DSDNN00050-12	●	40	140	0.3	50	0.35	
PSC50-DSDNN00060-12	●	50	165	0.3	60	0.75	SN00120400
PSC63-DSDNN00065-12	●	63	190	0.3	65	1.07	
PSC50-DSDNN00065-19	●	50	170	0.5	65	0.80	
PSC63-DSDNN00070-19	●	63	195	0.5	70	1.26	SN00190600

1/1

## SPARE PARTS

Tool holder type						
PSC40-DSDNN00050-12	MP1766	MPISSN-442	MP2712			
PSC50-DSDNN00060-12	MP1766	MPISSN-442	MP2712			
PSC63-DSDNN00065-12	MP1766	MPISSN-442	MP2712	MP1696	MP4295	MP5004
PSC50-DSDNN00065-19	MP1770	MPISSN-633	MP2719			
PSC63-DSDNN00070-19	MP1770	MPISSN-633	MP2719			

# DSSN 45°

## TOOL HOLDER FOR EXTERNAL TURNING AND CHAMFERING EQUIPPED WITH DOUBLE-SIDED SQUARE NEGATIVE INSERTS





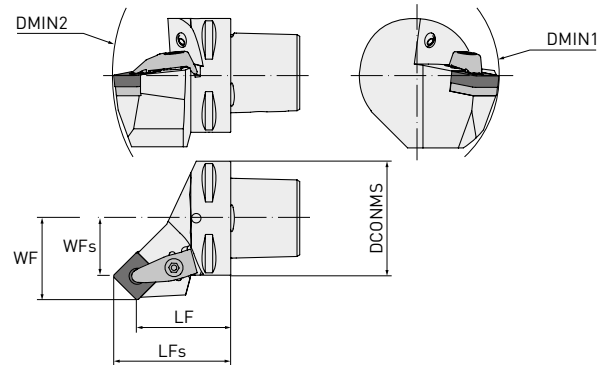



GAMF:  $-8^\circ$   
GAMP:  $0^\circ$



Order number	Stock	Hand	DCONMS	DMIN1	DMIN2	WF	WFs	LF	LFs	WT	Insert
PSC40-DSSNL27042-12	●	L	40	110	140	27	18.7	42	50.3	0.35	SN $\odot$ 1204 $\odot\odot$
PSC40-DSSNR27042-12	●	R	40	110	140	27	18.7	42	50.3	0.35	
PSC50-DSSNL35052-12	●	L	50	110	165	35	26.7	52	60.3	0.70	
PSC50-DSSNR35052-12	●	R	50	110	165	35	26.7	52	60.3	0.70	
PSC63-DSSNL45056-12	●	L	63	110	190	45	36.7	56	64.3	1.12	
PSC63-DSSNR45056-12	●	R	63	110	190	45	36.7	56	64.3	1.12	

1/1

## SPARE PARTS

Tool holder type						
PSC40-DSSNL27042-12						
PSC40-DSSNR27042-12						
PSC50-DSSNL35052-12	MP1766	MPISSN-442	MP2712	MP1696	MP4295	MP5004
PSC50-DSSNR35052-12						
PSC63-DSSNL45056-12						
PSC63-DSSNR45056-12						

# DVJN 93°

TOOL HOLDER FOR VERY SPECIFIC OPERATIONS EQUIPPED WITH RHOMBIC NEGATIVE DOUBLE-SIDED INSERTS





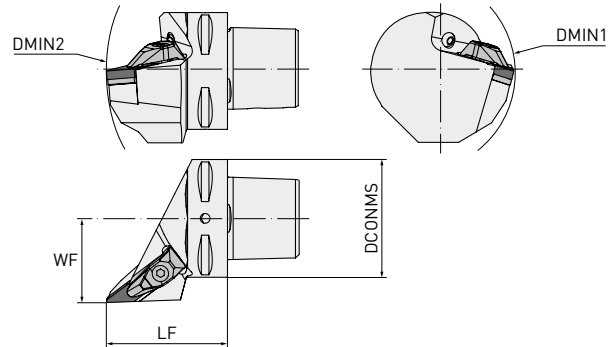



GAMF:  $-4^{\circ}$   
GAMP:  $-13^{\circ}$



Order number	Stock	Hand	DCONMS	DMIN1	DMIN2	WF	LF	WT	Insert
PSC40-DVJNL27062-16	●	L	40	60	152	27	62	0.45	VN $\odot$ 1604 $\odot$
PSC40-DVJNR27062-16	●	R	40	60	152	27	62	0.45	
PSC50-DVJNL35065-16	●	L	50	65	170	35	65	0.79	
PSC50-DVJNR35065-16	□	R	50	65	170	35	65	0.79	
PSC63-DVJNL45065-16	●	L	63	81	190	45	65	1.10	
PSC63-DVJNR45065-16	●	R	63	81	190	45	65	1.10	
PSC80-DVJNL55080-16	●	L	80	100	250	55	80	2.74	
PSC80-DVJNR55080-16	●	R	80	100	250	55	80	2.74	

1/1

## SPARE PARTS

Tool holder type						
PSC40-DVJNL27062-16						
PSC40-DVJNR27062-16						
PSC50-DVJNL35065-16						
PSC50-DVJNR35065-16	MP1764	MPIVSN-322	MP2708	MP1695	MP4294	MP5004
PSC63-DVJNL45065-16						
PSC63-DVJNR45065-16						
PSC80-DVJNL55080-16						
PSC80-DVJNR55080-16						

# DVNN 72° 30'

## PROFILING TOOLHOLDER EQUIPPED WITH RHOMBIC NEGATIVE DOUBLE-SIDED INSERTS





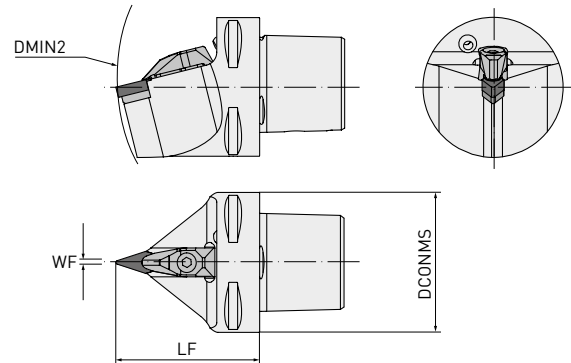



GAMF:  $-4^{\circ}$   
GAMP:  $-13^{\circ}$



Order number	Stock	DCONMS	DMIN2	WF	LF	WT	Insert
PSC40-DVNN00062-16	<input type="checkbox"/>	40	152	0.6	62	0.43	VNO1604
PSC50-DVNN00065-16	<input type="checkbox"/>	50	170	0.6	65	0.80	
PSC63-DVNN00065-16	<input type="checkbox"/>	63	190	0.6	65	1.07	
PSC80-DVNN00080-16	<input type="checkbox"/>	80	250	0.6	80	2.32	

1/1

## SPARE PARTS

Tool holder type						
PSC40-DVNN00062-16						
PSC50-DVNN00065-16	MP1764	MPIVSN-322	MP2708	MP1695	MP4294	MP5004
PSC63-DVNN00065-16						
PSC80-DVNN00080-16						

# DWLN 95°

## MULTI-PURPOSE TOOL HOLDER EQUIPPED WITH TRIGONAL NEGATIVE DOUBLE-SIDED INSERTS





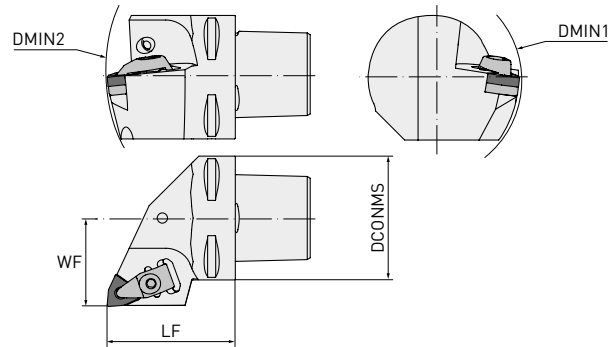



GAMF:  $-6^\circ$   
GAMP:  $-6^\circ$



Order number	Stock	Hand	DCONMS	DMIN1	DMIN2	WF	LF	WT	Insert
PSC40-DWLN27050-06	●	L	40	60	140	27	50	0.42	WN00060400
PSC40-DWLN27050-06	●	R	40	60	140	27	50	0.42	
PSC50-DWLN35060-06	●	L	50	65	165	35	60	0.80	
PSC50-DWLN35060-06	●	R	50	65	165	35	60	0.80	
PSC40-DWLN27050-08	●	L	40	110	140	27	50	0.42	WN00080400
PSC40-DWLN27050-08	●	R	40	110	140	27	50	0.42	
PSC50-DWLN35060-08	●	L	50	110	165	35	60	0.80	
PSC50-DWLN35060-08	●	R	50	110	165	35	60	0.80	
PSC63-DWLN45065-08	●	L	63	110	190	45	65	1.10	
PSC63-DWLN45065-08	●	R	63	110	190	45	65	1.10	
PSC80-DWLN55080-08	●	L	80	110	250	55	80	2.74	
PSC80-DWLN55080-08	●	R	80	110	250	55	80	2.74	

1/1

## SPARE PARTS

Tool holder type						
PSC40-DWLN27050-06	MP1764	MPIWSN-322	MP2708	MP1695	MP4294	MP5004
PSC40-DWLN27050-06	MP1764	MPIWSN-322	MP2708	MP1695	MP4294	
PSC50-DWLN35060-06	MP1764	MPIWSN-322	MP2708	MP1695	MP4294	
PSC50-DWLN35060-06	MP1764	MPIWSN-322	MP2708	MP1695	MP4294	
PSC40-DWLN27050-08	MP1766	MPIWSN-433	MP2712	MP1696	MP4295	
PSC40-DWLN27050-08	MP1766	MPIWSN-433	MP2712	MP1696	MP4295	
PSC50-DWLN35060-08	MP1766	MPIWSN-433	MP2712	MP1696	MP4295	
PSC50-DWLN35060-08	MP1766	MPIWSN-433	MP2712	MP1696	MP4295	
PSC63-DWLN45065-08	MP1766	MPIWSN-433	MP2712	MP1696	MP4295	
PSC63-DWLN45065-08	MP1766	MPIWSN-433	MP2712	MP1696	MP4295	
PSC80-DWLN55080-08	MP1766	MPIWSN-433	MP2712	MP1696	MP4295	
PSC80-DWLN55080-08	MP1766	MPIWSN-433	MP2712	MP1696	MP4295	

● : Inventory maintained.



# PCLN 95°

## MULTI-PURPOSE TOOL HOLDER EQUIPPED WITH RHOMBIC NEGATIVE DOUBLE-SIDED INSERTS



GAMF:  $-6^\circ$   
GAMP:  $-6^\circ$

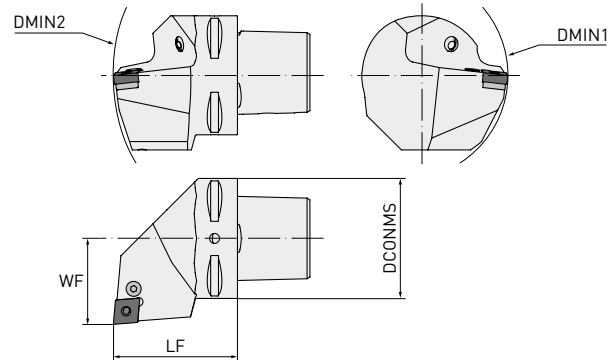





Order number	Stock	Hand	DCONMS	DMIN1	DMIN2	WF	LF	WT	Insert
PSC40-PCLNL27050-12	●	L	40	110	140	27	50	0.42	
PSC40-PCLNR27050-12	●	R	40	110	140	27	50	0.42	
PSC50-PCLNL35060-12	●	L	50	110	165	35	60	0.80	
PSC50-PCLNR35060-12	●	R	50	110	165	35	60	0.80	
PSC63-PCLNL45065-12	●	L	63	110	190	45	65	1.10	CN00120400
PSC63-PCLNR45065-12	●	R	63	110	190	45	65	1.10	
PSC80-PCLNL55080-12	●	L	80	110	250	55	80	2.74	
PSC80-PCLNR55080-12	●	R	80	110	250	55	80	2.74	
PSC50-PCLNL35060-16	●	L	50	125	165	35	60	0.80	
PSC50-PCLNR35060-16	●	R	50	125	165	35	60	0.80	
PSC63-PCLNL45065-16	●	L	63	125	190	45	65	1.10	
PSC63-PCLNR45065-16	●	R	63	125	190	45	65	1.10	CN00160600
PSC80-PCLNL55080-16	●	L	80	125	250	55	80	2.74	
PSC80-PCLNR55080-16	●	R	80	125	250	55	80	2.74	
PSC63-PCLNL45065-19	●	L	63	125	190	45	65	1.10	
PSC63-PCLNR45065-19	●	R	63	125	190	45	65	1.10	
PSC80-PCLNL55080-19	●	L	80	125	250	55	80	2.74	CN00190600
PSC80-PCLNR55080-19	●	R	80	125	250	55	80	2.74	

1/1

PCLN 95°

## SPARE PARTS

Tool holder type					
PSC40-PCLNL27050-12	MP8012	MP1608	MP5003	MP3612	MP4112
PSC40-PCLNR27050-12	MP8012	MP1608	MP5003	MP3612	MP4112
PSC50-PCLNL35060-12	MP8012	MP1608	MP5003	MP3612	MP4112
PSC50-PCLNR35060-12	MP8012	MP1608	MP5003	MP3612	MP4112
PSC63-PCLNL45065-12	MP8012	MP1608	MP5003	MP3612	MP4112
PSC63-PCLNR45065-12	MP8012	MP1608	MP5003	MP3612	MP4112
PSC80-PCLNL55080-12	MP8012	MP1608	MP5003	MP3612	MP4112
PSC80-PCLNR55080-12	MP8012	MP1608	MP5003	MP3612	MP4112
PSC50-PCLNL35060-16	MP8016	MP1618	MP5003	MP3616	MP4115
PSC50-PCLNR35060-16	MP8016	MP1618	MP5003	MP3616	MP4115
PSC63-PCLNL45065-16	MP8016	MP1618	MP5003	MP3616	MP4115
PSC63-PCLNR45065-16	MP8016	MP1618	MP5003	MP3616	MP4115
PSC80-PCLNL55080-16	MP8016	MP1618	MP5003	MP3616	MP4115
PSC80-PCLNR55080-16	MP8016	MP1618	MP5003	MP3616	MP4115
PSC63-PCLNL45065-19	MP8019	MP1610	MP5004	MP3619	MP4119
PSC63-PCLNR45065-19	MP8019	MP1610	MP5004	MP3619	MP4119
PSC80-PCLNL55080-19	MP8019	MP1610	MP5004	MP3619	MP4119
PSC80-PCLNR55080-19	MP8019	MP1610	MP5004	MP3619	MP4119

# PCRN 75°

## MULTI-PURPOSE TOOL HOLDER EQUIPPED WITH RHOMBIC NEGATIVE DOUBLE-SIDED INSERTS





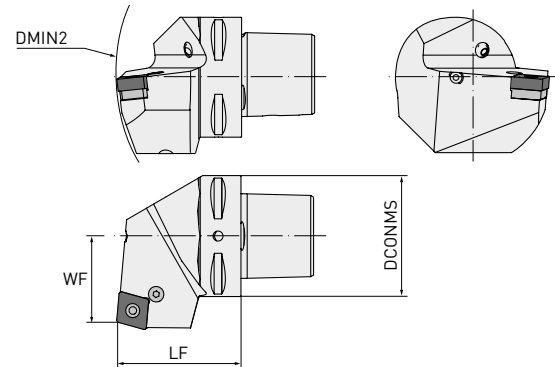

GAMF:  $-6^\circ$   
GAMP:  $-6^\circ$



Order number	Stock	Hand	DCONMS	DMIN2	WF	LF	WT	Insert
PSC63-PCRNL35065-16	●	L	63	190	35	65	1.40	CN $\odot$ 1606 $\odot\odot$
PSC63-PCRR35065-16	●	R						CN $\odot$ 1906 $\odot\odot$
PSC63-PCRNL35065-19	●	L						CN $\odot$ 1906 $\odot\odot$
PSC63-PCRR35065-19	●	R						

1/1

## SPARE PARTS

Tool holder type					
PSC63-PCRNL35065-16	MP8016	MP1618	MP5003	MP3616	MP4115
PSC63-PCRR35065-16	MP8016	MP1618	MP5003	MP3616	MP4115
PSC63-PCRNL35065-19	MP8019	MP1610	MP5004	MP3619	MP4119
PSC63-PCRR35065-19	MP8019	MP1610	MP5004	MP3619	MP4119

# PDJN 93°

## TURNING AND PROFILING TOOL HOLDER EQUIPPED WITH RHOMBIC NEGATIVE DOUBLE-SIDED INSERTS



GAMF:  $-6^\circ$   
GAMP:  $-7^\circ$

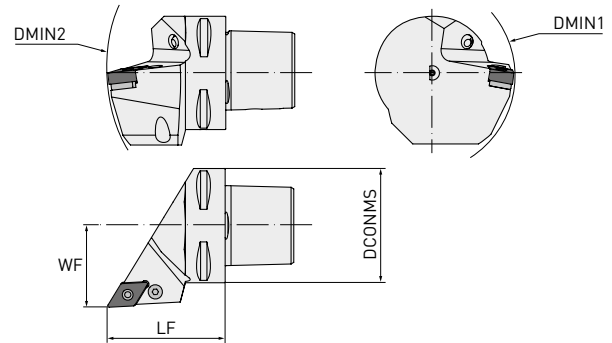

Order number	Stock	Hand	DCONMS	DMIN1	DMIN2	WF	LF	WT	Insert
PSC40-PDJNL27055-15	●	L	40	110	145	27	55	0.43	DN $\odot$ 150 $\odot\odot$
PSC40-PDJNR27055-15	●	R	40	110	145	27	55	0.43	
PSC50-PDJNL35060-15	●	L	50	110	165	35	60	0.80	
PSC50-PDJNR35060-15	●	R	50	110	165	35	60	0.80	
PSC63-PDJNL45065-15	□	L	63	110	190	45	65	1.10	
PSC63-PDJNR45065-15	●	R	63	110	190	45	65	1.10	
PSC80-PDJNL55080-15	●	L	80	110	250	55	80	2.74	
PSC80-PDJNR55080-15	●	R	80	110	250	55	80	2.74	

1/1

## SPARE PARTS

Tool holder type					
PSC40-PDJNL27055-15					
PSC40-PDJNR27055-15					
PSC50-PDJNL35060-15					
PSC50-PDJNR35060-15	MP8415	MP1638	MP5003	MP3715	MP4112
PSC63-PDJNL45065-15					
PSC63-PDJNR45065-15					
PSC80-PDJNL55080-15					
PSC80-PDJNR55080-15					

# PSDN 45°

TOOL HOLDER FOR EXTERNAL TURNING AND CHAMFERING  
EQUIPPED WITH SQUARE NEGATIVE DOUBLE-SIDED INSERTS





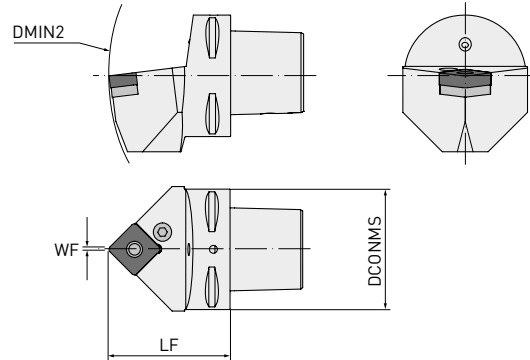

GAMF:  $-6^\circ$   
GAMP:  $-6^\circ$



Order number	Stock	DCONMS	DMIN2	WF	LF	WT	Insert
PSC63-PSDNN00065-12	<input type="checkbox"/>	63	190	0.3	65	1.07	SN $\odot$ 1204 $\odot$
PSC63-PSDNN00065-15	<input type="checkbox"/>	63	190	0.5	65	1.07	SN $\odot$ 1506 $\odot$
PSC63-PSDNN00065-19	<input type="checkbox"/>	63	195	0.5	65	1.07	SN $\odot$ 1906 $\odot$

1/1

## SPARE PARTS

Tool holder type					
PSC63-PSDNN00065-12	MP8012	MP1608	MP5003	MP3512	MP4112
PSC63-PSDNN00065-15	MP8016	MP1618	MP5003	MP3515	MP4115
PSC63-PSDNN00065-19	MP8019	MP1610	MP5004	MP3519	MP4119

# PSKN 75°

## TOOL HOLDER FOR FACE TURNING EQUIPPED WITH SQUARE NEGATIVE DOUBLE-SIDED INSERTS





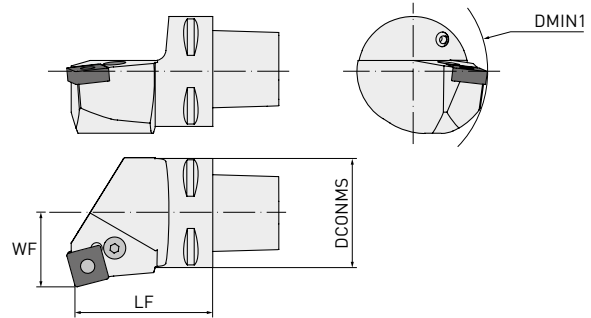

GAMF:  $-6^\circ$   
GAMP:  $-6^\circ$



Order number	Stock	Hand	DCONMS	DMIN1	WF	LF	WT	Insert
PSC63-PSKNL45065-12	●	L	63	110	45	65	1.10	SN00120400
PSC63-PSKNR45065-12	●	R	63	110	45	65	1.10	
PSC63-PSKNL45065-19	□	L	63	125	45	65	1.10	SN00190600
PSC63-PSKNR45065-19	□	R	63	125	45	65	1.10	
PSC80-PSKNL55080-19	□	L	80	125	55	80	2.74	SN00250700
PSC80-PSKNR55080-19	□	R	80	125	55	80	2.74	
PSC80-PSKNL55080-25	□	L	80	150	55	80	2.74	SN00250700
PSC80-PSKNR55080-25	□	R	80	150	55	80	2.74	

1/1

## SPARE PARTS

Tool holder type					
PSC63-PSKNL45065-12	MP8012	MP1608	MP5003	MP3512	MP4112
PSC63-PSKNR45065-12	MP8012	MP1608	MP5003	MP3512	MP4112
PSC63-PSKNL45065-19	MP8019	MP1610	MP5004	MP3519	MP4119
PSC63-PSKNR45065-19	MP8019	MP1610	MP5004	MP3519	MP4119
PSC80-PSKNL55080-19	MP8019	MP1610	MP5004	MP3519	MP4119
PSC80-PSKNR55080-19	MP8019	MP1610	MP5004	MP3519	MP4119
PSC80-PSKNL55080-25	MP8025	MP1612	MP5005	MP3525	MP4125
PSC80-PSKNR55080-25	MP8025	MP1612	MP5005	MP3525	MP4125

# PSRN 75°

## TOOL HOLDER FOR FACE TURNING EQUIPPED WITH SQUARE NEGATIVE DOUBLE-SIDED INSERTS





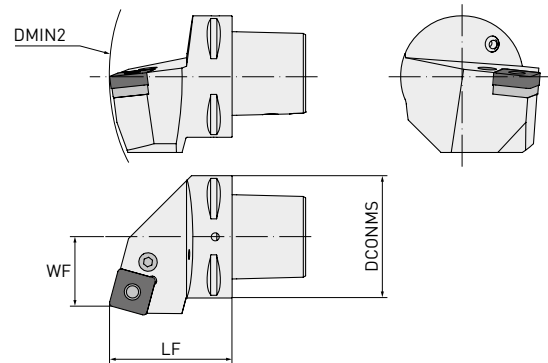

GAMF:  $-6^\circ$   
GAMP:  $-6^\circ$



Order number	Stock	Hand	DCONMS	DMIN2	WF	LF	WT	Insert
PSC63-PSRNL35065-19	<input type="checkbox"/>	L	63	190	35	65	1.40	SN $\odot$ 1906 $\odot$
PSC63-PSRNR35065-19	<input type="checkbox"/>	R	63	190	35	65	1.40	
PSC80-PSRNL45080-19	<input type="checkbox"/>	L	80	250	45	80	2.80	
PSC80-PSRNR45080-19	<input type="checkbox"/>	R	80	250	45	80	2.80	

1/1

## SPARE PARTS

Tool holder type					
PSC63-PSRNL35065-19					
PSC63-PSRNR35065-19	MP8019	MP1610	MP5004	MP3519	MP4119
PSC80-PSRNL45080-19					
PSC80-PSRNR45080-19					

# PSSN 45°

TOOL HOLDER FOR EXTERNAL TURNING AND CHAMFERING  
EQUIPPED WITH SQUARE NEGATIVE DOUBLE-SIDED INSERTS





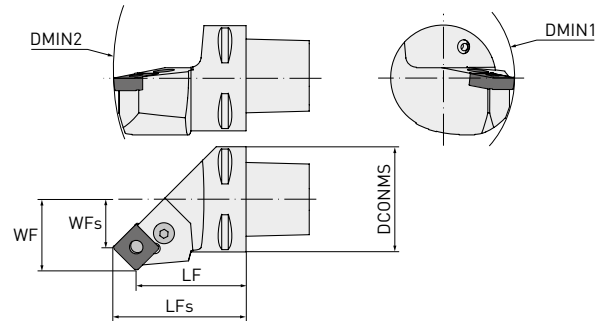

GAMF:  $-8^\circ$   
GAMP:  $0^\circ$



Order number	Stock	Hand	DCONMS	DMIN1	DMIN2	WF	WF <sub>s</sub>	LF	LF <sub>s</sub>	WT	Insert
PSC63-PSSNL45052-19	●	L	63	125	190	45	32.5	52	64.5	1.13	SN00190600
PSC63-PSSNR45052-19	●	R									

1/1

## SPARE PARTS

Tool holder type					
PSC63-PSSNL45052-19	MP8019	MP1610	MP5004	MP3519	MP4119
PSC63-PSSNR45052-19					



# SCLC 95°

## MULTI-PURPOSE TOOL HOLDER EQUIPPED WITH RHOMBIC POSITIVE INSERTS





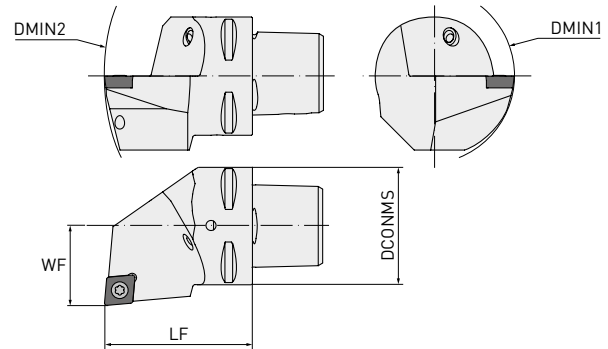

GAMF: 0°  
GAMP: 0°



Order number	Stock	Hand	DCONMS	DMIN1	DMIN2	WF	LF	WT	Insert
PSC40-SCLCL27050-09	●	L	40	80	140	27	50	0.42	CC0009T300
PSC40-SCLCR27050-09	●	R	40	80	140	27	50	0.42	
PSC50-SCLCL35060-09	●	L	50	80	165	35	60	0.80	
PSC50-SCLCR35060-09	●	R	50	80	165	35	60	0.80	
PSC40-SCLCL27050-12	●	L	40	110	140	27	50	0.42	CC00120400
PSC40-SCLCR27050-12	●	R	40	110	140	27	50	0.42	
PSC50-SCLCL35060-12	●	L	50	110	165	35	60	0.80	
PSC50-SCLCR35060-12	●	R	50	110	165	35	60	0.80	
PSC63-SCLCL45065-12	●	L	63	110	190	45	65	1.10	
PSC63-SCLCR45065-12	●	R	63	110	190	45	65	1.10	

1/1

## SPARE PARTS

Tool holder type				
PSC40-SCLCL27050-09	MP1240	MP5515		
PSC40-SCLCR27050-09	MP1240	MP5515		
PSC50-SCLCL35060-09	MP1240	MP5515		
PSC50-SCLCR35060-09	MP1240	MP5515		
PSC40-SCLCL27050-12	MP1540	MP5517		
PSC40-SCLCR27050-12	MP1540	MP5517		
PSC50-SCLCL35060-12	MP1540	MP5517		
PSC50-SCLCR35060-12	MP1540	MP5517	MP3614	MP1760
PSC63-SCLCL45065-12	MP1540	MP5517		
PSC63-SCLCR45065-12	MP1540	MP5517		

# SDJC 93°

## MULTI-PURPOSE TOOL HOLDER EQUIPPED WITH RHOMBIC POSITIVE INSERTS





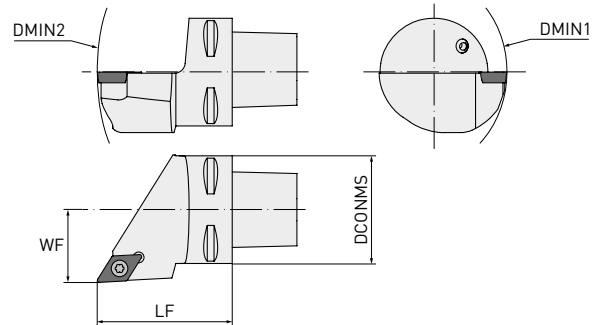

GAMF: 0°  
GAMP: 0°



Order number	Stock	Hand	DCONMS	DMIN1	DMIN2	WF	LF	WT	Insert
PSC40-SDJCL27050-11	●	L	40	110	140	27	50	0.42	DC0011T300
PSC40-SDJCR27050-11	●	R	40	110	140	27	50	0.42	
PSC50-SDJCL35060-11	●	L	50	110	165	35	60	0.80	
PSC50-SDJCR35060-11	●	R	50	110	165	35	60	0.80	
PSC63-SDJCL45065-11	●	L	63	110	190	45	65	1.10	
PSC63-SDJCR45065-11	●	R	63	110	190	45	65	1.10	

1/1

## SPARE PARTS

Tool holder type				
PSC40-SDJCL27050-11				
PSC40-SDJCR27050-11				
PSC50-SDJCL35060-11	MP1335	MP5516	MP3714	MP1750
PSC50-SDJCR35060-11				
PSC63-SDJCL45065-11				
PSC63-SDJCR45065-11				

# SDNC 62° 30'

## MULTI-PURPOSE PROFILING TOOL HOLDER EQUIPPED WITH RHOMBIC POSITIVE INSERTS



GAMF: 0°  
GAMP: 0°

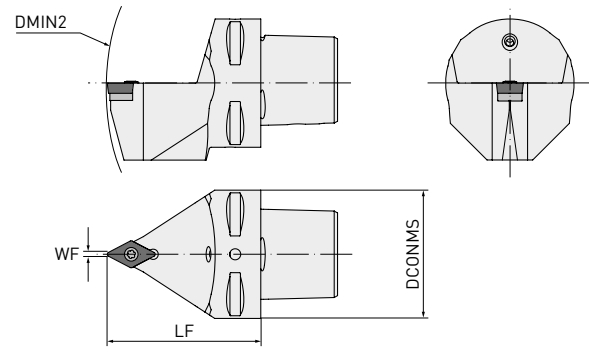

Order number	Stock	DCONMS	DMIN2	WF	LF	WT	Insert
PSC40-SDNCN00050-11	●	40	140	0.5	50	0.35	DC0011T300
PSC50-SDNCN00060-11	●	50	165	0.5	60	0.75	

1/1

## SPARE PARTS

Tool holder type



PSC40-SDNCN00050-11

MP1335

MP5516

MP3714

MP1750

PSC50-SDNCN00060-11

# SVHC 107° 30'

## MULTI-PURPOSE PROFILING TOOL HOLDER EQUIPPED WITH RHOMBIC POSITIVE INSERTS





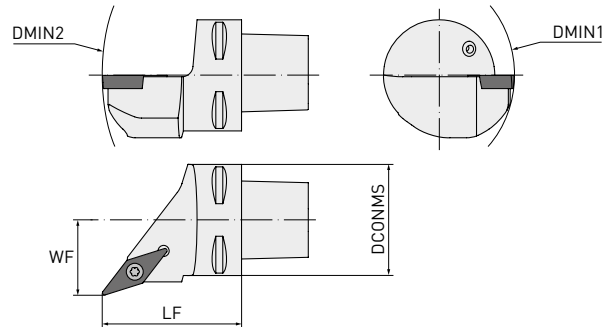

GAMF: 0°  
GAMP: 0°



Order number	Stock	Hand	DCONMS	DMIN1	DMIN2	WF	LF	WT	Insert
PSC40-SVHCL27050-11	●	L	40	80	140	27	50	0.42	VC <sup>00</sup> 1103 <sup>00</sup>
PSC40-SVHCR27050-11	●	R	40	80	140	27	50	0.42	
PSC40-SVHCL27050-16	●	L	40	110	140	27	50	0.42	
PSC40-SVHCR27050-16	●	R	40	110	140	27	50	0.42	
PSC50-SVHCL35060-16	●	L	50	110	165	35	60	0.80	VC <sup>00</sup> 1604 <sup>00</sup>
PSC50-SVHCR35060-16	●	R	50	110	165	35	60	0.80	
PSC63-SVHCL45065-16	●	L	63	110	190	45	65	1.10	
PSC63-SVHCR45065-16	●	R	63	110	190	45	65	1.10	

1/1

## SPARE PARTS

Tool holder type				
PSC40-SVHCL27050-11	MP1225	MP5507		
PSC40-SVHCR27050-11	MP1225	MP5507		
PSC40-SVHCL27050-16	MP1335	MP5516		
PSC40-SVHCR27050-16	MP1335	MP5516		
PSC50-SVHCL35060-16	MP1335	MP5516		
PSC50-SVHCR35060-16	MP1335	MP5516	MP3718	MP1750
PSC63-SVHCL45065-16	MP1335	MP5516		
PSC63-SVHCR45065-16	MP1335	MP5516		

# SVJC 93°

## MULTI-PURPOSE PROFILING TOOL HOLDER EQUIPPED WITH RHOMBIC POSITIVE INSERTS



GAMF: 0°



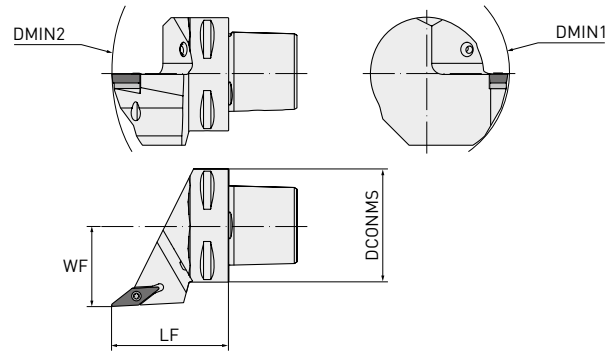

GAMP: 0°



Order number	Stock	Hand	DCONMS	DMIN1	DMIN2	WF	LF	WT	Insert
PSC40-SVJCL27050-11	●	L	40	80	145	27	50	0.42	VC00110300
PSC40-SVJCR27050-11	●	R	40	80	145	27	50	0.42	
PSC40-SVJCL27050-16	●	L	40	110	145	27	50	0.42	
PSC40-SVJCR27050-16	●	R	40	110	145	27	50	0.42	
PSC50-SVJCL35060-16	●	L	50	110	165	35	60	0.80	VC00160400
PSC50-SVJCR35060-16	●	R	50	110	165	35	60	0.80	
PSC63-SVJCL45065-16	●	L	63	110	190	45	65	1.10	
PSC63-SVJCR45065-16	●	R	63	110	190	45	65	1.10	

1/1

## SPARE PARTS

Tool holder type				
PSC40-SVJCL27050-11	MP1225	MP5507		
PSC40-SVJCR27050-11	MP1225	MP5507		
PSC40-SVJCL27050-16	MP1335	MP5516	MP3718	MP1750
PSC40-SVJCR27050-16	MP1335	MP5516	MP3718	MP1750
PSC50-SVJCL35060-16	MP1335	MP5516	MP3718	MP1750
PSC50-SVJCR35060-16	MP1335	MP5516	MP3718	MP1750
PSC63-SVJCL45065-16	MP1335	MP5516	MP3718	MP1750
PSC63-SVJCR45065-16	MP1335	MP5516	MP3718	MP1750

# SVVC 72° 30'

## MULTI-PURPOSE PROFILING TOOL HOLDER EQUIPPED WITH RHOMBIC POSITIVE INSERTS





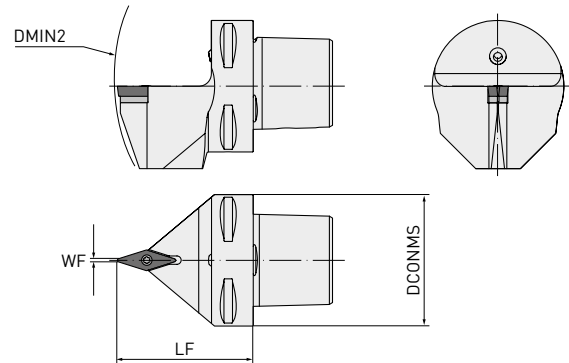

GAMF: 0°  
GAMP: 0°



Order number	Stock	DCONMS	DMIN2	WF	LF	WT	Insert
PSC40-SVVCN00050-11	<input type="checkbox"/>	40	140	0.3	50	0.35	VC00110300
PSC40-SVVCN00050-16	<input type="checkbox"/>	40	140	0.6	50	0.35	
PSC50-SVVCN00060-16	<input type="checkbox"/>	50	165	0.6	60	0.75	VC00160400
PSC63-SVVCN00065-16	<input type="checkbox"/>	63	190	0.6	65	1.07	

1/1

## SPARE PARTS

Tool holder type				
PSC40-SVVCN00050-11	MP1225	MP5507		
PSC40-SVVCN00050-16	MP1335	MP5516	MP3718	MP1750
PSC50-SVVCN00060-16	MP1335	MP5516	MP3718	MP1750
PSC63-SVVCN00065-16	MP1335	MP5516	MP3718	MP1750

# PCLN 95°

## BORING BAR FOR INTERNAL TURNING EQUIPPED WITH RHOMBIC NEGATIVE DOUBLE-SIDED INSERTS





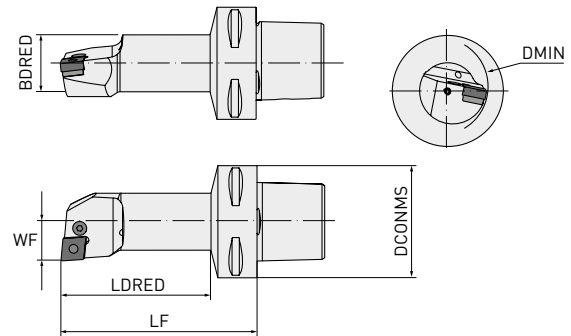

GAMF:  $-6^\circ$



Order number	Stock	Hand	DCONMS	DMIN	BDRED	WF	LF	LDRED	GAMP	WT	Insert
PSC40-PCLNL13080-09	●	L	40	25	20	13	80	58	$-11^\circ$	0.40	CN00090300
PSC40-PCLNR13080-09	●	R	40	25	20	13	80	58	$-11^\circ$	0.40	
PSC50-PCLNL13080-09	●	L	50	25	20	13	80	56	$-11^\circ$	0.57	
PSC50-PCLNR13080-09	●	R	50	25	20	13	80	56	$-11^\circ$	0.57	
PSC40-PCLNL17090-12	●	L	40	32	25	17	90	69	$-11^\circ$	0.48	CN00120400
PSC40-PCLNR17090-12	●	R	40	32	25	17	90	69	$-11^\circ$	0.48	
PSC40-PCLNL22110-12	●	L	40	40	32	22	110	89	$-11^\circ$	0.75	
PSC40-PCLNR22110-12	●	R	40	40	32	22	110	89	$-11^\circ$	0.75	
PSC40-PCLNL27120-12	●	L	40	50	40	27	120	100	$-11^\circ$	1.13	CN00160600
PSC40-PCLNR27120-12	●	R	40	50	40	27	120	100	$-11^\circ$	1.13	
PSC50-PCLNL17090-12	●	L	50	32	25	17	90	67	$-11^\circ$	0.70	CN00160600
PSC50-PCLNR17090-12	●	R	50	32	25	17	90	67	$-11^\circ$	0.70	
PSC50-PCLNL22110-12	●	L	50	40	32	22	110	88	$-11^\circ$	0.93	
PSC50-PCLNR22110-12	●	R	50	40	32	22	110	88	$-11^\circ$	0.93	
PSC50-PCLNL27140-12	●	L	50	50	40	27	140	119	$-10^\circ$	1.47	CN00160600
PSC50-PCLNR27140-12	●	R	50	50	40	27	140	119	$-10^\circ$	1.47	
PSC50-PCLNL35100-12	●	L	50	63	50	35	100	81	$-7^\circ$	1.48	CN00160600
PSC50-PCLNR35100-12	●	R	50	63	50	35	100	81	$-7^\circ$	1.48	
PSC63-PCLNL17100-12	●	L	63	32	25	17	100	74	$-11^\circ$	1	CN00160600
PSC63-PCLNR17100-12	●	R	63	32	25	17	100	74	$-11^\circ$	1	
PSC63-PCLNL22110-12	●	L	63	40	32	22	110	84	$-11^\circ$	1.26	
PSC63-PCLNR22110-12	●	R	63	40	32	22	110	84	$-11^\circ$	1.26	
PSC50-PCLNL35150-16	●	L	50	63	50	35	150	131	$-11^\circ$	2.25	CN00160600
PSC50-PCLNR35150-16	●	R	50	63	50	35	150	131	$-11^\circ$	2.25	
PSC63-PCLNL27140-16	●	L	63	50	40	27	140	115	$-11^\circ$	1.78	
PSC63-PCLNR27140-16	●	R	63	50	40	27	140	115	$-11^\circ$	1.78	
PSC63-PCLNL35175-16	●	L	63	63	50	35	175	152	$-11^\circ$	2.85	CN00160600
PSC63-PCLNR35175-16	●	R	63	63	50	35	175	152	$-11^\circ$	2.85	

PCLN 95°

## SPARE PARTS

Tool holder type					
PSC40-PCLNL13080-09	MP8005	MP1605	MP5002		
PSC40-PCLNR13080-09	MP8005	MP1605	MP5002		
PSC50-PCLNL13080-09	MP8005	MP1605	MP5002		
PSC50-PCLNR13080-09	MP8005	MP1605	MP5002		
PSC40-PCLNL17090-12	MP8212	MP1626	MP5025		
PSC40-PCLNR17090-12	MP8212	MP1626	MP5025		
PSC40-PCLNL22110-12	MP8312	MP1648	MP5003	MP3612	MP4112
PSC40-PCLNR22110-12	MP8312	MP1648	MP5003	MP3612	MP4112
PSC40-PCLNL27120-12	MP8012	MP1608	MP5003	MP3612	MP4112
PSC40-PCLNR27120-12	MP8012	MP1608	MP5003	MP3612	MP4112
PSC50-PCLNL17090-12	MP8212	MP1626	MP5025		
PSC50-PCLNR17090-12	MP8212	MP1626	MP5025		
PSC50-PCLNL22110-12	MP8312	MP1648	MP5003	MP3612	MP4112
PSC50-PCLNR22110-12	MP8312	MP1648	MP5003	MP3612	MP4112
PSC50-PCLNL27140-12	MP8012	MP1608	MP5003	MP3612	MP4112
PSC50-PCLNR27140-12	MP8012	MP1608	MP5003	MP3612	MP4112
PSC50-PCLNL35100-12	MP8012	MP1608	MP5003	MP3612	MP4112
PSC50-PCLNR35100-12	MP8012	MP1608	MP5003	MP3612	MP4112
PSC63-PCLNL17100-12	MP8212	MP1626	MP5025		
PSC63-PCLNR17100-12	MP8212	MP1626	MP5025		
PSC63-PCLNL22110-12	MP8312	MP1648	MP5003	MP3612	MP4112
PSC63-PCLNR22110-12	MP8312	MP1648	MP5003	MP3612	MP4112
PSC50-PCLNL35150-16	MP8016	MP1618	MP5003	MP3616	MP4115
PSC50-PCLNR35150-16	MP8016	MP1618	MP5003	MP3616	MP4115
PSC63-PCLNL27140-16	MP8016	MP1618	MP5003	MP3616	MP4115
PSC63-PCLNR27140-16	MP8016	MP1618	MP5003	MP3616	MP4115
PSC63-PCLNL35175-16	MP8016	MP1618	MP5003	MP3616	MP4115
PSC63-PCLNR35175-16	MP8016	MP1618	MP5003	MP3616	MP4115



# PDUN 93°

## BORING BAR FOR INTERNAL TURNING AND PROFILING WITH RHOMBIC NEGATIVE DOUBLE-SIDED INSERTS

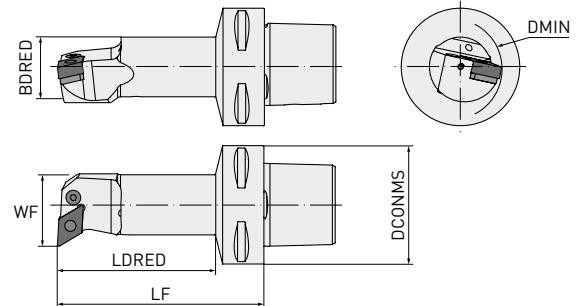



GAMF:  $-6^\circ$ 

Order number	Stock	Hand	DCONMS	DMIN	BDRED	WF	LF	LDRED	GAMP	WT	Insert
PSC40-PDUNL17090-11	●	L	40	32	25	17	90	69	$-11^\circ$	0.48	DN $\odot$ 1104 $\odot\odot$
PSC40-PDUNR17090-11	●	R	40	32	25	17	90	69	$-11^\circ$	0.48	
PSC40-PDUNL22110-11	●	L	40	40	32	22	110	89	$-10^\circ$	0.75	
PSC40-PDUNR22110-11	●	R	40	40	32	22	110	89	$-10^\circ$	0.75	
PSC50-PDUNL17090-11	●	L	50	32	25	17	90	67	$-11^\circ$	0.70	
PSC50-PDUNR17090-11	●	R	50	32	25	17	90	67	$-11^\circ$	0.70	
PSC50-PDUNL22110-11	●	L	50	40	32	22	110	88	$-10^\circ$	0.93	
PSC50-PDUNR22110-11	●	R	50	40	32	22	110	88	$-10^\circ$	0.93	
PSC63-PDUNL17100-11	●	L	63	32	25	17	100	74	$-11^\circ$	1	
PSC63-PDUNR17100-11	●	R	63	32	25	17	100	74	$-11^\circ$	1	
PSC40-PDUNL27080-15	●	L	40	50	40	27	80	60	$-11^\circ$	0.74	
PSC40-PDUNR27080-15	●	R	40	50	40	27	80	60	$-11^\circ$	0.74	
PSC40-PDUNL27120-15	●	L	40	50	40	27	120	100	$-11^\circ$	1.13	
PSC40-PDUNR27120-15	●	R	40	50	40	27	120	100	$-11^\circ$	1.13	
PSC50-PDUNL27140-15	●	L	50	50	40	27	140	119	$-11^\circ$	1.47	DN $\odot$ 1506 $\odot\odot$
PSC50-PDUNR27140-15	●	R	50	50	40	27	140	119	$-11^\circ$	1.47	
PSC50-PDUNL35150-15	●	L	50	63	50	35	150	131	$-10^\circ$	2.25	
PSC50-PDUNR35150-15	●	R	50	63	50	35	150	131	$-10^\circ$	2.25	
PSC63-PDUNL22110-15	●	L	63	40	32	22	110	84	$-12^\circ$	1.26	
PSC63-PDUNR22110-15	●	R	63	40	32	22	110	84	$-12^\circ$	1.26	
PSC63-PDUNL27140-15	●	L	63	50	40	27	140	115	$-11^\circ$	1.78	
PSC63-PDUNR27140-15	●	R	63	50	40	27	140	115	$-11^\circ$	1.78	
PSC63-PDUNL35175-15	●	L	63	63	50	35	175	152	$-10^\circ$	2.85	
PSC63-PDUNR35175-15	●	R	63	63	50	35	175	152	$-10^\circ$	2.85	

1/1

PDUN 93°

## SPARE PARTS

Tool holder type					
PSC40-PDUNL17090-11	MP8009	MP1606	MP5025	MP3711	MP4109
PSC40-PDUNR17090-11	MP8009	MP1606	MP5025	MP3711	MP4109
PSC40-PDUNL22110-11	MP8009	MP1606	MP5025	MP3711	MP4109
PSC40-PDUNR22110-11	MP8009	MP1606	MP5025	MP3711	MP4109
PSC50-PDUNL17090-11	MP8009	MP1606	MP5025	MP3711	MP4109
PSC50-PDUNR17090-11	MP8009	MP1606	MP5025	MP3711	MP4109
PSC50-PDUNL22110-11	MP8009	MP1606	MP5025	MP3711	MP4109
PSC50-PDUNR22110-11	MP8009	MP1606	MP5025	MP3711	MP4109
PSC63-PDUNL17100-11	MP8009	MP1606	MP5025	MP3711	MP4109
PSC63-PDUNR17100-11	MP8009	MP1606	MP5025	MP3711	MP4109
PSC40-PDUNL27080-15	MP8415	MP1638	MP5003	MP3715	MP4112
PSC40-PDUNR27080-15	MP8415	MP1638	MP5003	MP3715	MP4112
PSC40-PDUNL27120-15	MP8415	MP1638	MP5003	MP3715	MP4112
PSC40-PDUNR27120-15	MP8415	MP1638	MP5003	MP3715	MP4112
PSC50-PDUNL27140-15	MP8415	MP1638	MP5003	MP3715	MP4112
PSC50-PDUNR27140-15	MP8415	MP1638	MP5003	MP3715	MP4112
PSC50-PDUNL35150-15	MP8415	MP1638	MP5003	MP3715	MP4112
PSC50-PDUNR35150-15	MP8415	MP1638	MP5003	MP3715	MP4112
PSC63-PDUNL22110-15	MP8415	MP1638	MP5003	MP3715	MP4112
PSC63-PDUNR22110-15	MP8415	MP1638	MP5003	MP3715	MP4112
PSC63-PDUNL27140-15	MP8415	MP1638	MP5003	MP3715	MP4112
PSC63-PDUNR27140-15	MP8415	MP1638	MP5003	MP3715	MP4112
PSC63-PDUNL35175-15	MP8415	MP1638	MP5003	MP3715	MP4112
PSC63-PDUNR35175-15	MP8415	MP1638	MP5003	MP3715	MP4112

# SCLC 95°

## MULTI-PURPOSE BORING BAR EQUIPPED WITH RHOMBIC POSITIVE INSERTS

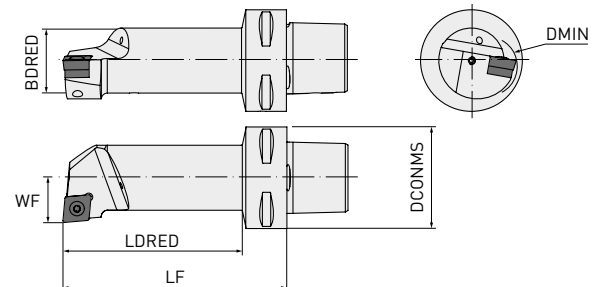





GAMF: 0°

Order number	Stock	Hand	DCONMS	DMIN	BDRED	WF	LF	LDRED	GAMP	WT	Insert
PSC40-SCLCL11070-09	●	L	40	20	16	11	70	47	-12°	0.33	
PSC40-SCLCR11070-09	●	R	40	20	16	11	70	47	-12°	0.33	
PSC40-SCLCL13080-09	●	L	40	25	20	13	80	58	-8°	0.40	
PSC40-SCLCR13080-09	●	R	40	25	20	13	80	58	-8°	0.40	
PSC40-SCLCL17090-09	●	L	40	32	25	17	90	69	-6°	0.48	
PSC40-SCLCR17090-09	●	R	40	32	25	17	90	69	-6°	0.48	
PSC50-SCLCL11070-09	●	L	50	20	16	11	70	46	-12°	0.50	CC0009T300
PSC50-SCLCR11070-09	●	R	50	20	16	11	70	46	-12°	0.50	
PSC50-SCLCL13080-09	●	L	50	25	20	13	80	56	-8°	0.57	
PSC50-SCLCR13080-09	●	R	50	25	20	13	80	56	-8°	0.57	
PSC50-SCLCL17090-09	●	L	50	32	25	17	90	67	-6°	0.70	
PSC50-SCLCR17090-09	●	R	50	32	25	17	90	67	-6°	0.70	
PSC50-SCLCL35100-09	●	L	50	63	49.7	35	100	81	-4°	1.48	
PSC50-SCLCR35100-09	●	R	50	63	49.7	35	100	81	-4°	1.48	
PSC40-SCLCL22110-12	●	L	40	40	32	22	110	89	-10°	0.75	CC00120400
PSC40-SCLCR22110-12	●	R	40	40	32	22	110	89	-10°	0.75	
PSC50-SCLCL22110-12	●	L	50	40	32	22	110	88	-10°	0.93	
PSC50-SCLCR22110-12	●	R	50	40	32	22	110	88	-10°	0.93	
PSC50-SCLCL27140-12	●	L	50	50	40	27	140	119	-8°	1.47	
PSC50-SCLCR27140-12	●	R	50	50	40	27	140	119	-8°	1.47	
PSC50-SCLCL35100-12	●	L	50	63	49.7	35	100	80	-5°	1.48	
PSC50-SCLCR35100-12	●	R	50	63	49.7	35	100	80	-5°	1.48	

1/1

SCLC 95°

## SPARE PARTS

Tool holder type				
PSC40-SCLCL11070-09	MP1440	MP5515		
PSC40-SCLCR11070-09	MP1440	MP5515		
PSC40-SCLCL13080-09	MP1440	MP5515		
PSC40-SCLCR13080-09	MP1440	MP5515		
PSC40-SCLCL17090-09	MP1240	MP5515		
PSC40-SCLCR17090-09	MP1240	MP5515		
PSC50-SCLCL11070-09	MP1440	MP5515		
PSC50-SCLCR11070-09	MP1440	MP5515		
PSC50-SCLCL13080-09	MP1440	MP5515		
PSC50-SCLCR13080-09	MP1440	MP5515		
PSC50-SCLCL17090-09	MP1240	MP5515		
PSC50-SCLCR17090-09	MP1240	MP5515		
PSC50-SCLCL35100-09	MP1240	MP5515		
PSC50-SCLCR35100-09	MP1240	MP5515		
PSC40-SCLCL22110-12	MP1540	MP5517	MP3614	MP1760
PSC40-SCLCR22110-12	MP1540	MP5517	MP3614	MP1760
PSC50-SCLCL22110-12	MP1540	MP5517	MP3614	MP1760
PSC50-SCLCL27140-12	MP1540	MP5517	MP3614	MP1760
PSC50-SCLCL35100-12	MP1540	MP5517	MP3614	MP1760
PSC50-SCLCR22110-12	MP1540	MP5517	MP3614	MP1760
PSC50-SCLCR27140-12	MP1540	MP5517	MP3614	MP1760
PSC50-SCLCR35100-12	MP1540	MP5517	MP3614	MP1760

# SDUC 93°

## MULTI-PURPOSE PROFILING BORING BAR EQUIPPED WITH RHOMBIC POSITIVE INSERTS



GAMP: 0°

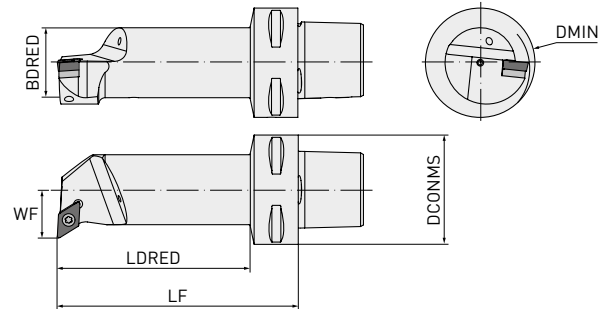





Order number	Stock	Hand	DCONMS	DMIN	BDRED	WF	LF	LDRED	GAMP	WT	Insert
PSC40-SDUCL11070-07	●	L	40	20	16	11	70	47	-8°	0.33	DC00070200
PSC40-SDUCR11070-07	●	R	40	20	16	11	70	47	-8°	0.33	
PSC50-SDUCL11070-07	●	L	50	20	16	11	70	46	-8°	0.50	
PSC50-SDUCR11070-07	●	R	50	20	16	11	70	46	-8°	0.50	
PSC40-SDUCL13080-11	●	L	40	25	20	13	80	58	-6°	0.40	DC0011T300
PSC40-SDUCR13080-11	●	R	40	25	20	13	80	58	-6°	0.40	
PSC40-SDUCL17090-11	●	L	40	32	25	17	90	69	-6°	0.48	
PSC40-SDUCR17090-11	●	R	40	32	25	17	90	69	-6°	0.48	
PSC40-SDUCL22110-11	●	L	40	40	32	22	110	89	-6°	0.75	DC0011T300
PSC40-SDUCR22110-11	●	R	40	40	32	22	110	89	-6°	0.75	
PSC40-SDUCL27080-11	●	L	40	50	40	27	80	60	-6°	0.74	
PSC40-SDUCR27080-11	●	R	40	50	40	27	80	60	-6°	0.74	
PSC50-SDUCL13080-11	●	L	50	25	20	13	80	56	-6°	0.57	DC0011T300
PSC50-SDUCR13080-11	●	R	50	25	20	13	80	56	-6°	0.57	
PSC50-SDUCL17090-11	●	L	50	32	25	17	90	67	-6°	0.70	
PSC50-SDUCR17090-11	●	R	50	32	25	17	90	67	-6°	0.70	
PSC50-SDUCL22110-11	●	L	50	40	32	22	110	88	-6°	0.93	DC0011T300
PSC50-SDUCR22110-11	●	R	50	40	32	22	110	88	-6°	0.93	
PSC50-SDUCL35100-11	●	L	50	63	49.7	35	100	81	-4°	1.48	
PSC50-SDUCR35100-11	●	R	50	63	49.7	35	100	81	-4°	1.48	

1/1

SDUC 93°

## SPARE PARTS

Tool holder type				
PSC40-SDUCL11070-07	MP1225	MP5507		
PSC40-SDUCR11070-07	MP1225	MP5507		
PSC50-SDUCL11070-07	MP1225	MP5507		
PSC50-SDUCR11070-07	MP1225	MP5507		
PSC40-SDUCL13080-11	MP1240	MP5515		
PSC40-SDUCR13080-11	MP1240	MP5515		
PSC40-SDUCL17090-11	MP1240	MP5515		
PSC40-SDUCR17090-11	MP1240	MP5515		
PSC40-SDUCL22110-11	MP1335	MP5516	MP3714	MP1750
PSC40-SDUCR22110-11	MP1335	MP5516	MP3714	MP1750
PSC40-SDUCL27080-11	MP1335	MP5516	MP3714	MP1750
PSC40-SDUCR27080-11	MP1335	MP5516	MP3714	MP1750
PSC50-SDUCL13080-11	MP1240	MP5515		
PSC50-SDUCR13080-11	MP1240	MP5515		
PSC50-SDUCL17090-11	MP1240	MP5515		
PSC50-SDUCR17090-11	MP1240	MP5515		
PSC50-SDUCL22110-11	MP1335	MP5516	MP3714	MP1750
PSC50-SDUCR22110-11	MP1335	MP5516	MP3714	MP1750
PSC50-SDUCL35100-11	MP1335	MP5516	MP3714	MP1750
PSC50-SDUCR35100-11	MP1335	MP5516	MP3714	MP1750

# SVQC 107° 30'

## MULTI-PURPOSE PROFILING BORING BAR EQUIPPED WITH RHOMBIC POSITIVE INSERTS





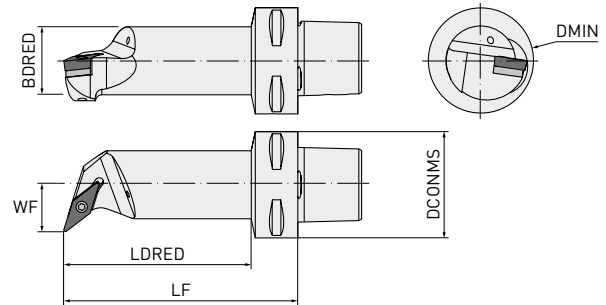

GAMF: 0°  
GAMP: -8°



Order number	Stock	Hand	DCONMS	DMIN	BDRED	WF	LF	LDRED	WT	Insert
PSC63-SVQCL22120-16	●	L	63	40	32	22	120	94	1.28	VC00160400
PSC63-SVQCR22120-16	●	R	63	40	32	22	120	94	1.28	
PSC63-SVQCL27145-16	●	L	63	50	40	27	145	120	1.78	
PSC63-SVQCR27145-16	●	R	63	50	40	27	145	120	1.78	
PSC63-SVQCL35175-16	●	L	63	63	50	35	175	152	2.85	
PSC63-SVQCR35175-16	●	R	63	63	50	35	175	152	2.85	

1/1

## SPARE PARTS

Tool holder type				
PSC63-SVQCL22120-16				
PSC63-SVQCL27145-16				
PSC63-SVQCL35175-16	MP1335			
PSC63-SVQCR22120-16		MP5516		
PSC63-SVQCR27145-16			MP3718	
PSC63-SVQCR35175-16				MP1750

# EXTERNAL THREADING 90°

## MULTI-PURPOSE THREADING TOOL HOLDER FOR NEGATIVE THREADING INSERTS

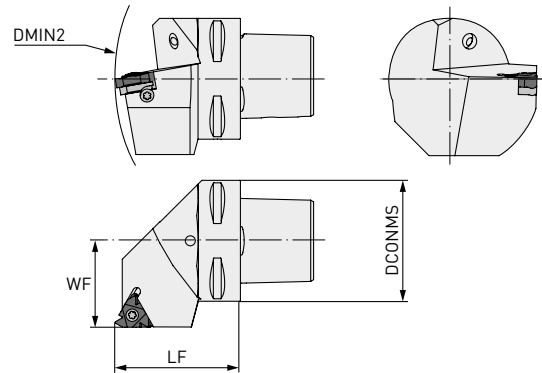

Order number	Stock	Hand	DCONMS	DMIN2	WF	LF	WT	Insert
PSC40-SEL27050-16	<input type="checkbox"/>	L	40	140	27	50	0.42	MMT16E $\odot\odot$
PSC40-SER27050-16	<input checked="" type="checkbox"/>	R	40	140	27	50	0.42	
PSC50-SEL35060-16	<input type="checkbox"/>	L	50	165	35	60	0.80	
PSC50-SER35060-16	<input checked="" type="checkbox"/>	R	50	165	35	60	0.80	
PSC63-SEL45065-16	<input type="checkbox"/>	L	63	190	45	65	1.10	
PSC63-SER45065-16	<input checked="" type="checkbox"/>	R	63	190	45	65	1.10	
PSC40-SEL27050-22	<input type="checkbox"/>	L	40	140	27	50	0.42	MMT22E $\odot\odot$
PSC40-SER27050-22	<input checked="" type="checkbox"/>	R	40	140	27	50	0.42	
PSC50-SEL35060-22	<input type="checkbox"/>	L	50	165	35	60	0.80	
PSC50-SER35060-22	<input checked="" type="checkbox"/>	R	50	165	35	60	0.80	
PSC63-SEL45065-22	<input type="checkbox"/>	L	63	190	45	65	1.10	
PSC63-SER45065-22	<input checked="" type="checkbox"/>	R	63	190	45	65	1.10	

1/1

## SPARE PARTS

### Tool holder type



PSC40-SEL27050-16	MPSA3	MP5510	MPYI3	MPSY3
PSC40-SER27050-16	MPSA3	MP5510	MPYE3	MPSY3
PSC50-SEL35060-16	MPSA3	MP5510	MPYI3	MPSY3
PSC50-SER35060-16	MPSA3	MP5510	MPYE3	MPSY3
PSC63-SEL45065-16	MPSA3	MP5510	MPYI3	MPSY3
PSC63-SER45065-16	MPSA3	MP5510	MPYE3	MPSY3
PSC40-SEL27050-22	MPSA4	MP5520	MPYI4	MPSY4
PSC40-SER27050-22	MPSA4	MP5520	MPYE4	MPSY4
PSC50-SEL35060-22	MPSA4	MP5520	MPYI4	MPSY4
PSC50-SER35060-22	MPSA4	MP5520	MPYE4	MPSY4
PSC63-SEL45065-22	MPSA4	MP5520	MPYI4	MPSY4
PSC63-SER45065-22	MPSA4	MP5520	MPYE4	MPSY4



# INTERNAL THREADING 90°

## MULTI-PURPOSE THREADING TOOL HOLDER FOR NEGATIVE THREADING INSERTS

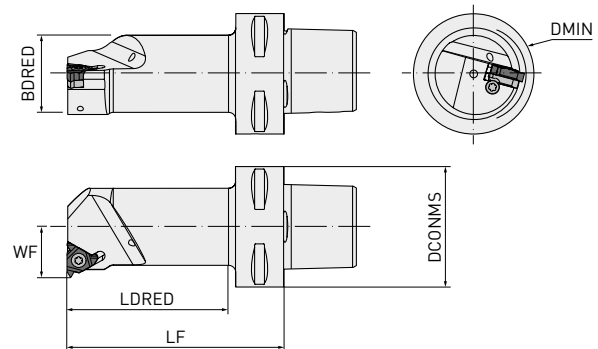





Order number	Stock	Hand	DCONMS	DMIN	WF	LF	BDRED	LDRED	WT	Insert
PSC40-SIL12060-16	□	L	40	20	12	60	15.5	37	0.30	
PSC40-SIR12060-16	●	R	40	20	12	60	15.5	37	0.30	
PSC40-SIL14060-16	□	L	40	25	14	60	18.5	38	0.34	
PSC40-SIR14060-16	●	R	40	25	14	60	18.5	38	0.34	
PSC40-SIL17070-16	□	L	40	32	17	70	24.5	48	0.41	
PSC40-SIR17070-16	●	R	40	32	17	70	24.5	48	0.41	
PSC40-SIL22090-16	□	L	40	40	22	90	32	69	0.65	
PSC40-SIR22090-16	●	R	40	40	22	90	35	69	0.65	
PSC40-SIL27080-16	□	L	40	50	27	80	39.5	60	0.76	
PSC40-SIR27080-16	●	R	40	50	27	80	39.5	60	0.76	
PSC50-SIL12060-16	□	L	50	20	12	60	15.5	35	0.49	
PSC50-SIR12060-16	●	R	50	20	12	60	15.5	35	0.49	
PSC50-SIL14060-16	□	L	50	25	14	60	18.5	36	0.51	
PSC50-SIR14060-16	●	R	50	25	14	60	18.5	36	0.51	
PSC50-SIL17070-16	□	L	50	32	17	70	24.5	47	0.59	MMT161
PSC50-SIR17070-16	●	R	50	32	17	70	24.5	47	0.59	
PSC50-SIL22090-16	□	L	50	40	22	90	24.5	68	0.82	
PSC50-SIR22090-16	●	R	50	40	22	90	24.5	68	0.82	
PSC50-SIL27105-16	□	L	50	50	27	105	40	84	1.20	
PSC50-SIR27105-16	●	R	50	50	27	105	40	84	1.20	
PSC63-SIL14070-16	□	L	63	25	14	70	18.5	42	0.90	
PSC63-SIR14070-16	●	R	63	25	14	70	18.5	42	0.90	
PSC63-SIL17075-16	□	L	63	32	17	75	24.5	48	0.97	
PSC63-SIR17075-16	●	R	63	32	17	75	24.5	48	0.97	
PSC63-SIL22090-16	□	L	63	40	22	90	32	64	1.14	
PSC63-SIR22090-16	●	R	63	40	22	90	32	64	1.14	
PSC63-SIL27105-16	□	L	63	50	27	105	40	80	1.20	
PSC63-SIR27105-16	●	R	63	50	27	105	40	80	1.20	
PSC40-SIL15065-22	□	L	40	25	15	65	18.5	42	0.35	
PSC40-SIR15065-22	●	R	40	25	15	65	18.5	42	0.35	
PSC40-SIL19070-22	□	L	40	32	19	70	25	48	0.42	MMT221
PSC40-SIR19070-22	●	R	40	32	19	70	25	48	0.42	

## INTERNAL THREADING 90°

Order number	Stock	Hand	DCONMS	DMIN	WF	LF	BDRED	LDRED	WT	Insert
PSC40-SIL22090-22	☐	L	40	40	22	90	31.5	69	0.65	
PSC40-SIR22090-22	●	R	40	40	22	90	31.5	69	0.65	
PSC40-SIL27080-22	☐	L	40	50	27	80	39.5	60	0.76	
PSC40-SIR27080-22	●	R	40	50	27	80	39.5	60	0.76	
PSC50-SIL15065-22	☐	L	50	25	15	65	18.5	41	0.35	
PSC50-SIR15065-22	●	R	50	25	15	65	18.5	41	0.35	
PSC50-SIL19070-22	☐	L	50	32	19	70	25	48	0.60	
PSC50-SIR19070-22	●	R	50	32	19	70	25	48	0.60	
PSC50-SIL22090-22	☐	L	50	40	22	90	31.5	68	0.82	MMT22100
PSC50-SIR22090-22	●	R	50	40	22	90	31.5	68	0.82	
PSC50-SIL27105-22	☐	L	50	50	27	105	40	84	1.20	
PSC50-SIR27105-22	●	R	50	50	27	105	40	84	1.20	
PSC63-SIL19075-22	☐	L	63	32	19	75	25	48	0.97	
PSC63-SIR19075-22	●	R	63	32	19	75	25	48	0.97	
PSC63-SIL22090-22	☐	L	63	40	22	90	31.5	64	1.14	
PSC63-SIR22090-22	●	R	63	40	22	90	31.5	64	1.14	
PSC63-SIL27105-22	☐	L	63	50	27	105	40	80	1.50	
PSC63-SIR27105-22	●	R	63	50	27	105	40	80	1.50	

2/2





## SPARE PARTS

Tool holder type					
PSC40-SIL12060-16	MPSN3	MP5510	—	—	
PSC40-SIR12060-16	MPSN3	MP5510	—	—	
PSC40-SIL14060-16	MPSA3T	MP5510	MPYE3	MPYI3	MPSY3
PSC40-SIR14060-16	MPSA3T	MP5510	MPYE3	MPYI3	MPSY3
PSC40-SIL17070-16	MPSA3	MP5510	MPYE3	MPYI3	MPSY3
PSC40-SIR17070-16	MPSA3	MP5510	MPYE3	MPYI3	MPSY3
PSC40-SIL22090-16	MPSA3	MP5510	MPYE3	MPYI3	MPSY3
PSC40-SIR22090-16	MPSA3	MP5510	MPYE3	MPYI3	MPSY3
PSC40-SIL27080-16	MPSA3	MP5510	MPYE3	MPYI3	MPSY3
PSC40-SIR27080-16	MPSA3	MP5510	MPYE3	MPYI3	MPSY3
PSC50-SIL12060-16	MPSN3	MP5510	—	—	
PSC50-SIR12060-16	MPSN3	MP5510	—	—	
PSC50-SIL14060-16	MPSA3T	MP5510	MPYE3	MPYI3	MPSY3
PSC50-SIR14060-16	MPSA3T	MP5510	MPYE3	MPYI3	MPSY3
PSC50-SIL17070-16	MPSA3	MP5510	MPYE3	MPYI3	MPSY3
PSC50-SIR17070-16	MPSA3	MP5510	MPYE3	MPYI3	MPSY3
PSC50-SIL22090-16	MPSA3	MP5510	MPYE3	MPYI3	MPSY3
PSC50-SIR22090-16	MPSA3	MP5510	MPYE3	MPYI3	MPSY3
PSC50-SIL27105-16	MPSA3	MP5510	MPYE3	MPYI3	MPSY3
PSC50-SIR27105-16	MPSA3	MP5510	MPYE3	MPYI3	MPSY3
PSC63-SIL14070-16	MPSA3T	MP5510	MPYE3	MPYI3	MPSY3
PSC63-SIR14070-16	MPSA3T	MP5510	MPYE3	MPYI3	MPSY3

1/2

## INTERNAL THREADING 90°

## SPARE PARTS

Tool holder type			 	
PSC63-SIL17075-16	MPSA3	MP5510	MPYE3	MPSY3
PSC63-SIR17075-16	MPSA3	MP5510	MPYI3	MPSY3
PSC63-SIL22090-16	MPSA3	MP5510	MPYE3	MPSY3
PSC63-SIR22090-16	MPSA3	MP5510	MPYI3	MPSY3
PSC63-SIL27105-16	MPSA3	MP5510	MPYE3	MPSY3
PSC63-SIR27105-16	MPSA3	MP5510	MPYI3	MPSY3
PSC40-SIL15065-22	MPSN4	MP5520	—	
PSC40-SIR15065-22	MPSN4	MP5520	—	
PSC40-SIL19070-22	MPSA4	MP5520	MPYE4	MPSY4
PSC40-SIR19070-22	MPSA4	MP5520	MPYI4	MPSY4
PSC40-SIL22090-22	MPSA4	MP5520	MPYE4	MPSY4
PSC40-SIR22090-22	MPSA4	MP5520	MPYI4	MPSY4
PSC40-SIL27080-22	MPSA4	MP5520	MPYE4	MPSY4
PSC40-SIR27080-22	MPSA4	MP5520	MPYI4	MPSY4
PSC50-SIL15065-22	MPSN4	MP5520	—	
PSC50-SIR15065-22	MPSN4	MP5520	—	
PSC50-SIL19070-22	MPSA4	MP5520	MPYE4	MPSY4
PSC50-SIR19070-22	MPSA4	MP5520	MPYI4	MPSY4
PSC50-SIL22090-22	MPSA4	MP5520	MPYE4	MPSY4
PSC50-SIR22090-22	MPSA4	MP5520	MPYI4	MPSY4
PSC50-SIL27105-22	MPSA4	MP5520	MPYE4	MPSY4
PSC50-SIR27105-22	MPSA4	MP5520	MPYI4	MPSY4
PSC63-SIL19075-22	MPSA4	MP5520	MPYE4	MPSY4
PSC63-SIR19075-22	MPSA4	MP5520	MPYI4	MPSY4
PSC63-SIL22090-22	MPSA4	MP5520	MPYE4	MPSY4
PSC63-SIR22090-22	MPSA4	MP5520	MPYI4	MPSY4
PSC63-SIL27105-22	MPSA4	MP5520	MPYE4	MPSY4
PSC63-SIR27105-22	MPSA4	MP5520	MPYI4	MPSY4

# THREADING

## HELIX CHART

### RIGHT HAND THREAD / TOOL

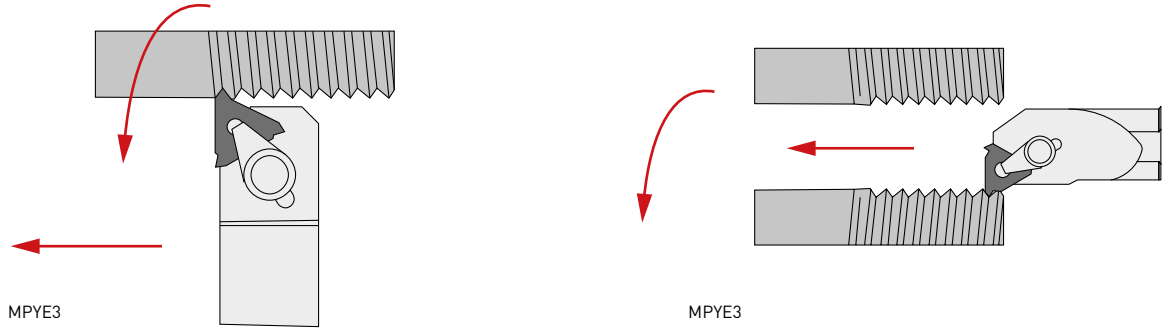

### LEFT HAND THREAD / TOOL

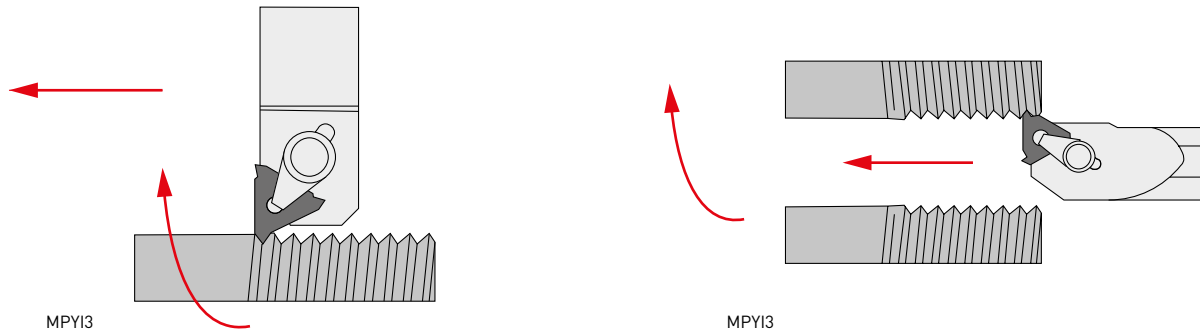

### SHIM TO GIVE CORRECT HELIX

Insert size	+3°	+2°	+1°	0°	
MMT16E	MP3424P3	MP3424P2	MP3424P1	MPYE3	
MMT16I	MP3425P3	MP3425P2	MP3425P1	MPYI3	
Insert size	-3°	-2°	-1°	0°	
MMT16E	MP3424M3	MP3424M2	MP3424M1	MPYE3	
MMT16I	MP3425M3	MP3425M2	MP3425M1	MPYI3	

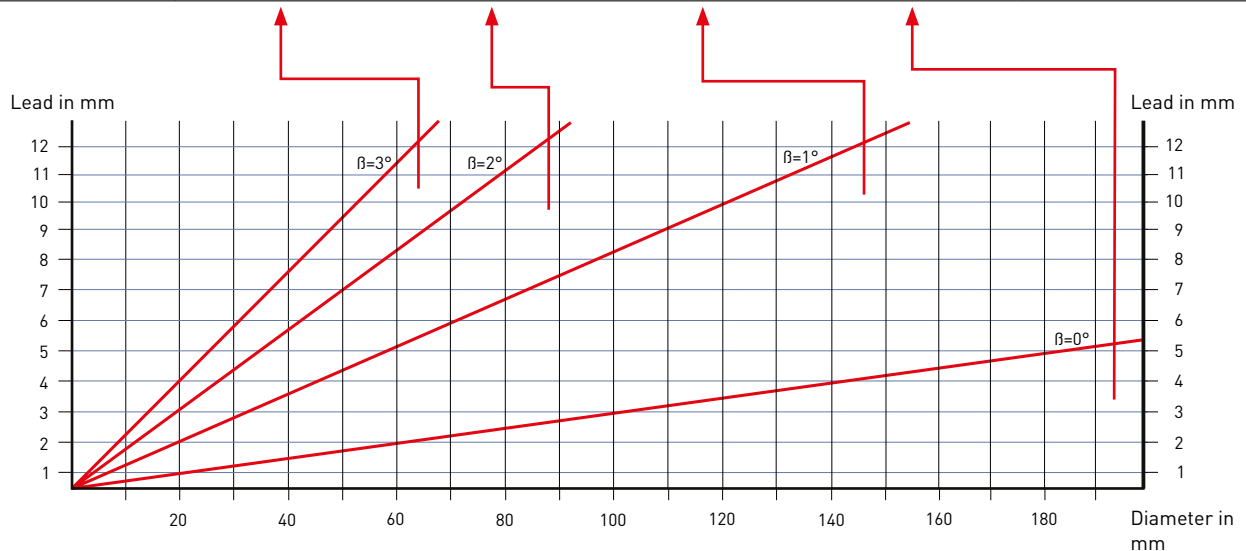

# CRSN

## PROFILING MULTI-PURPOSE TURNING TOOL HOLDER EQUIPPED WITH ROUND NEGATIVE DOUBLE-SIDED INSERTS



GAMF:  $-6^\circ$   
GAMP:  $-6^\circ$

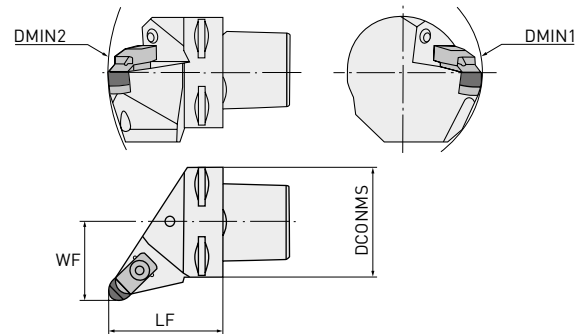

Order number	Stock	Hand	DCONMS	DMIN1	DMIN2	LF	WF	WT	Insert
PSC40-CRSNL27050-124	●	L	40	110	140	50	27	0.42	RNGN1204 <sup>○○</sup>
PSC40-CRSNR27050-124	●	R	40	110	140	50	27	0.42	
PSC50-CRSNL35060-124	●	L	50	110	165	60	35	0.80	
PSC50-CRSNR35060-124	●	R	50	110	165	60	35	0.80	
PSC63-CRSNL45065-124	●	L	63	110	190	65	45	1.10	
PSC63-CRSNR45065-124	●	R	63	110	190	65	45	1.10	
PSC40-CRSNL27050-127	●	L	40	110	140	50	27	0.42	RNGN1207 <sup>○○</sup>
PSC40-CRSNR27050-127	●	R	40	110	140	50	27	0.42	
PSC50-CRSNL35060-127	●	L	50	110	165	60	35	0.80	
PSC50-CRSNR35060-127	●	R	50	110	165	60	35	0.80	
PSC63-CRSNL45065-127	●	L	63	110	190	65	45	1.10	
PSC63-CRSNR45065-127	●	R	63	110	190	65	45	1.10	

1/1

## SPARE PARTS

Tool holder type



PSC40-CRSNL27050-124	MPIRSN44					
PSC40-CRSNR27050-124	MPIRSN44					
PSC50-CRSNL35060-124	MPIRSN44					
PSC50-CRSNR35060-124	MPIRSN44					
PSC63-CRSNL45065-124	MPIRSN44					
PSC63-CRSNR45065-124	MPIRSN44					
PSC40-CRSNL27050-127	MPIRSN42	MP1766	MP9414	MP2713	MP1086	MP5004
PSC40-CRSNR27050-127	MPIRSN42					
PSC50-CRSNL35060-127	MPIRSN42					
PSC50-CRSNR35060-127	MPIRSN42					
PSC63-CRSNL45065-127	MPIRSN42					
PSC63-CRSNR45065-127	MPIRSN42					

# MA TYPE ADAPTOR

## SHELL MILL ADAPTOR

### FOR CUTTERS WITH DRIVE SLOT – DIN 138

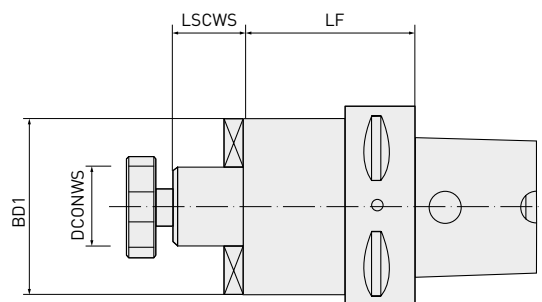

Order number	Stock	PSC	DCONWS	LF	LSCWS	BD1
PSC63-MA-16063	●	63	16	63	17	37
PSC63-MA-22100	●	63	22	100	19	47
PSC63-MA-27100	●	63	27	100	21	58
PSC63-MA-32100	●	63	32	100	24	63

1/1

## SPARE PARTS

Tool holder type



PSC63-MA-16063	MP10008	MP86016	MP11103
PSC63-MA-22100	MP10010	MP86022	MP11004
PSC63-MA-27100	MP10012	MP86027	MP11005
PSC63-MA-32100	MP10016	MP86032	MP11005

# MS TYPE SCREWED SHANK

## ADAPTOR FOR SCREW IN TYPE MILLING CUTTERS

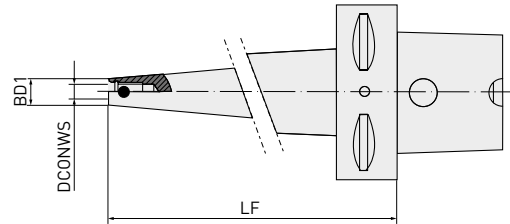

Order number	Stock	PSC	LF	DCONWS	BD1
PSC63-MS-10090	●	63	90	M10	18
PSC63-MS-12100	●	63	100	M12	21
PSC63-MS-16100	●	63	100	M16	29

1/1

# B-TYPE BORING BAR HOLDER

## BORING BAR HOLDERS PSC ISO 26623-1

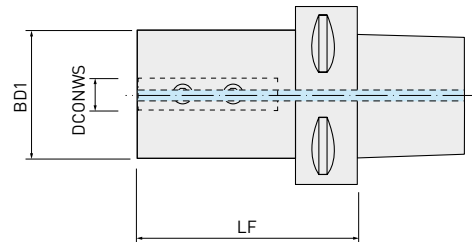

Order number	Stock	PSC	DCONWS	LF	BD1
PSC40-B-08050	●	50	08	50	44
PSC40-B-10050	●	40	10	50	44
PSC40-B-12050	●	40	12	50	44
PSC40-B-16050	●	40	16	50	44
PSC40-B-20050	●	40	20	50	44
PSC40-B-25060	●	40	25	60	50
PSC50-B-08052	●	50	08	52	44
PSC50-B-10052	●	50	10	52	44
PSC50-B-12052	●	50	12	52	44
PSC50-B-16052	●	50	16	52	44
PSC50-B-20052	●	50	20	52	50
PSC50-B-25060	●	50	25	60	55
PSC63-B-08060	●	63	08	60	44
PSC63-B-10060	●	63	10	60	44
PSC63-B-12060	●	63	12	60	44
PSC63-B-16060	●	63	16	60	44
PSC63-B-20060	●	63	20	60	50
PSC63-B-25072	●	63	25	72	55
PSC63-B-32075	●	63	32	75	55
PSC63-B-40085	●	63	40	85	65
PSC80-B-16085	□	80	16	85	44
PSC80-B-20085	□	80	20	85	50
PSC80-B-25085	□	80	25	85	55
PSC80-B-32085	□	80	32	85	72
PSC80-B-40095	□	80	40	95	65
PSC80-B-50100	□	80	50	100	75

1/1



**B-TYPE BORING BAR HOLDER****SPARE PARTS****Tool holder type**

PSC40-B-08050	MP14206
PSC40-B-10050	MP14208
PSC40-B-12050	MP14208
PSC40-B-16050	MP14210
PSC40-B-20050	MP14210
PSC40-B-25060	MP14210
PSC50-B-08052	MP14206
PSC50-B-10052	MP14208
PSC50-B-12052	MP14208
PSC50-B-16052	MP14210
PSC50-B-20052	MP14210
PSC50-B-25060	MP14210
PSC63-B-08060	MP14206
PSC63-B-10060	MP14208
PSC63-B-12060	MP14208
PSC63-B-16060	MP14210
PSC63-B-20060	MP14210
PSC63-B-25072	MP14210
PSC63-B-32075	MP14210
PSC63-B-40085	MP14210
PSC80-B-16085	MP14210
PSC80-B-20085	MP14210
PSC80-B-25085	MP14210
PSC80-B-32085	MP17110
PSC80-B-40095	MP14210
PSC80-B-50100	MP14210

# C-TYPE COLLET CHUCKS

COLLET CHUCKS FOR DIN 6499 (ERC) COLLETS FOR  
TOOLS WITH CYLINDRICAL SHANK DIN 1835-A

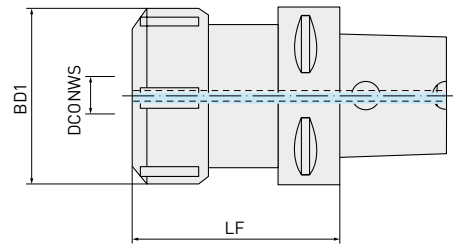



Order number	Stock	PSC	LF	DCONWS	BD1
PSC40-C-16060	☐	40	60	0.5 – 10	28
PSC40-C-20060	☐	40	60	1.0 – 13	34
PSC40-C-25060	☐	40	60	1.0 – 16	42
PSC40-C-32060	☐	40	60	2.0 – 20	50
PSC50-C-16060	☐	50	60	0.5 – 10	28
PSC50-C-16100	☐	50	100	0.5 – 10	28
PSC50-C-20060	☐	50	60	1.0 – 13	34
PSC50-C-20100	☐	50	100	1.0 – 13	34
PSC50-C-25060	☐	50	60	1.0 – 16	42
PSC50-C-25100	☐	50	100	1.0 – 16	42
PSC50-C-32060	☐	50	60	2.0 – 20	50
PSC50-C-32100	☐	50	100	2.0 – 20	50
PSC50-C-40060	☐	50	65	3.0 – 30	63
PSC50-C-40100	☐	50	100	3.0 – 30	63
PSC63-C-16060	☐	63	60	0.5 – 10	28
PSC63-C-16100	☐	63	100	0.5 – 10	28
PSC63-C-20060	☐	63	60	1.0 – 13	34
PSC63-C-20100	☐	63	100	1.0 – 13	34
PSC63-C-25060	☐	63	60	1.0 – 16	42
PSC63-C-25100	☐	63	100	1.0 – 16	42
PSC63-C-32060	☐	63	60	2.0 – 20	50
PSC63-C-32100	☐	63	100	2.0 – 20	50
PSC63-C-40070	☐	63	70	3.0 – 30	63
PSC63-C-40120	☐	63	120	3.0 – 30	63
PSC80-C-32070	☐	80	70	2.0 – 20	50
PSC80-C-32160	☐	80	160	2.0 – 20	50
PSC80-C-40070	☐	80	70	3.0 – 30	63
PSC80-C-40160	☐	80	160	3.0 – 30	63

1/1

## C-TYPE COLLET CHUCKS

## SPARE PARTS

Tool holder type			
PSC40-C-16060	MPERC1600	MP45316	MP50216
PSC40-C-20060	MPERC2000	MP45320	MP50220
PSC40-C-25060	MPERC2500	MP45325	MP50225
PSC40-C-32060	MPERC3200	MP45332	MP50232
PSC50-C-16060	MPERC1600	MP45316	MP50216
PSC50-C-16100	MPERC1600	MP45316	MP50216
PSC50-C-20060	MPERC2000	MP45320	MP50220
PSC50-C-20100	MPERC2000	MP45320	MP50220
PSC50-C-25060	MPERC2500	MP45325	MP50225
PSC50-C-25100	MPERC2500	MP45325	MP50225
PSC50-C-32060	MPERC3200	MP45332	MP50232
PSC50-C-32100	MPERC3200	MP45332	MP50232
PSC50-C-40060	MPERC4000	MP45340	MP50240
PSC50-C-40100	MPERC4000	MP45340	MP50240
PSC63-C-16060	MPERC1600	MP45316	MP50216
PSC63-C-16100	MPERC1600	MP45316	MP50216
PSC63-C-20060	MPERC2000	MP45320	MP50220
PSC63-C-20100	MPERC2000	MP45320	MP50220
PSC63-C-25060	MPERC2500	MP45325	MP50225
PSC63-C-25100	MPERC2500	MP45325	MP50225
PSC63-C-32060	MPERC3200	MP45332	MP50232
PSC63-C-32100	MPERC3200	MP45332	MP50232
PSC63-C-40070	MPERC4000	MP45340	MP50240
PSC63-C-40120	MPERC4000	MP45340	MP50240
PSC80-C-32070	MPERC3200	MP45332	MP50232
PSC80-C-32160	MPERC3200	MP45332	MP50232
PSC80-C-40070	MPERC4000	MP45340	MP50240
PSC80-C-40160	MPERC4000	MP45340	MP50240

# TA-TYPE ADAPTOR

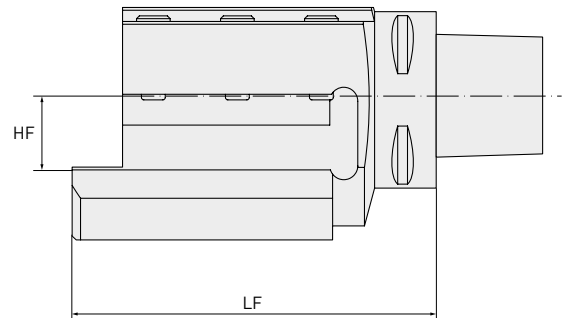

## ADAPTOR WITH AXIAL MOUNTING ADAPTOR FOR SQUARE TURNING TOOL HOLDER LEFT/RIGHT HAND



Order number	Stock	PSC	HF	LF
PSC50-TA-20098L	●	50	20	98
PSC50-TA-20098R	●	50	20	98
PSC63-TA-20100L	●	63	20	100
PSC63-TA-20100R	●	63	20	100
PSC63-TA-25130L	●	63	25	130
PSC63-TA-25130R	●	63	25	130
PSC63-TA-32134L	●	63	32	134
PSC63-TA-32134R	●	63	32	134
PSC80-TA-32140L	□	80	32	140
PSC80-TA-32140R	□	80	32	140

1/1

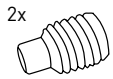
## SPARE PARTS

Tool holder type	2x 	
PSC50-TA-20098L	MP17010	
PSC50-TA-20098R	MP17010	
PSC63-TA-20100L	MP17110	
PSC63-TA-20100R	MP17110	
PSC63-TA-25130L	MP17012	
PSC63-TA-25130R	MP17012	MP29716
PSC63-TA-32134L	MP17012	
PSC63-TA-32134R	MP17012	
PSC80-TA-32140L	MP17012	
PSC80-TA-32140R	MP17012	

# TR-TYPE ADAPTOR

## RADIAL MOUNTING - MULTI-PURPOSE ADAPTOR FOR SQUARE TOOL HOLDERS

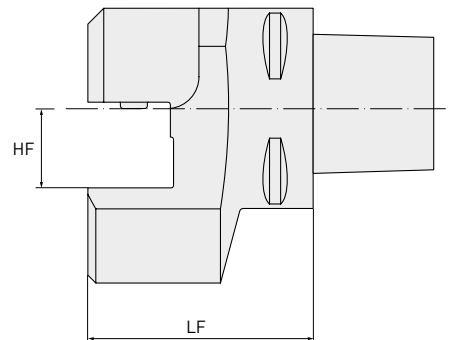

Order number	Stock	PSC	HF	LF
PSC50-TR-20058	●	50	20	58
PSC63-TR-25071	●	63	25	71
PSC63-TR-32071	●	63	32	71
PSC80-TR-32085	□	80	32	85

1/1

## SPARE PARTS

Tool holder type

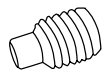

PSC50-TR-20058	MP17112	
PSC63-TR-25071	MP17012	
PSC63-TR-32071	MP17012	MP29716
PSC80-TR-32085	MP17012	

# AC-TYPE CAPS

## AUTOMATIC CAPS

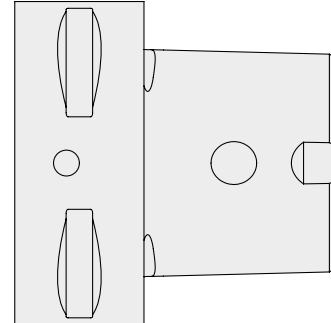

Order number	Stock	Automatic cap
PSC40-AC	●	40
PSC50-AC	●	50
PSC63-AC	●	63
PSC80-AC	●	80

1/1

**NEW**

# 415SD

FIRST CHOICE FOR HIGH-FEED MACHINING OF  
TITANIUM ALLOYS



*Mplus...*

# 415SD

## FOR HIGH-FEED EFFICIENT MACHINING



### HIGH-FEED MILLING CUTTER CONCEPT FOR STABILITY AND HIGH PERFORMANCE

- Unevenly spaced cutting edges reduce vibrations, especially in long overhang applications.
- Fine and extra fine pitch types enable a highly efficient cutting performance.
- Carefully selected steel for the tool body is capable of safely absorbing machining forces. In addition, the nickel coating increases wear and corrosion protection.
- The insert location in the holder combined with the ideal geometry and a precisely positioned coolant outlet achieves maximum stability and machining performance.

### CUTTING PERFORMANCE

The approach angle of 15° achieves an APMX of 2 mm, which enables a high removal rate but with low radial forces.

### TARGETED APPLICATIONS

The use of different diameters and the precise positioning of the coolant nozzles enables perfect chip removal as well as reducing and dissipating the high temperatures that occur at the cutting edge.

### SAFE, PRECISE AND RELIABLE

Exact positioning, secure insert clamping with large contact surfaces offers the possibility of high-performance and efficient high-feed machining of stainless steels and heat resistant materials.

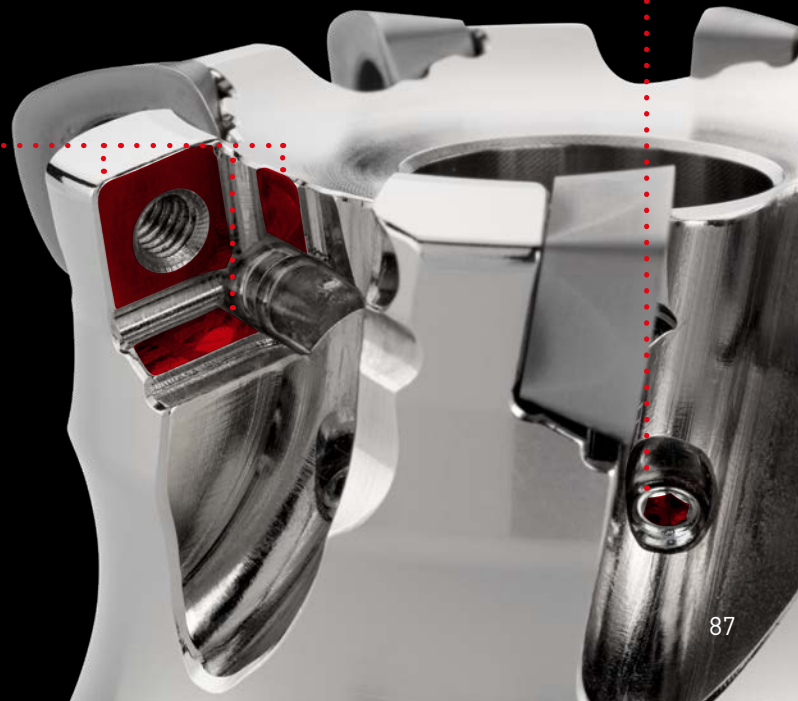



# 415SD

## INSERTS FOR HIGH-FEED EFFICIENT MACHINING

### THE PVD-COATED, HIGH-PERFORMANCE GRADE MP9130 FOCUSES ON TITANIUM MACHINING

- High-feed face milling including radial, plunge and ramping operations.
- Ideal for machining components that require a long overhang.
- Highly suitable for low power machines and low rigidity component clamping.

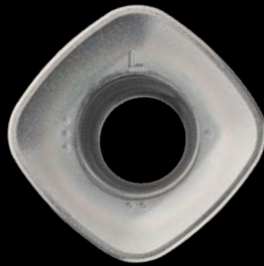

**L-BREAKER**

Ideal for applications that require low cutting resistance.



**M-BREAKER**

First recommendation - ideal combination of cutting edge stability and low cutting resistance.

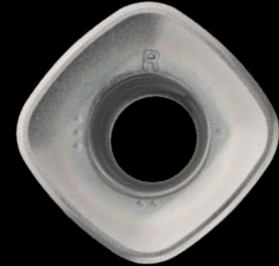

**R-BREAKER**

High cutting edge stability, for heavy interrupted machining or difficult cutting conditions.



**Highest productivity even when applications require low cutting resistance.**

- Low power consumption.
- Designed to achieve low radial cutting forces.
- Process reliability and long tool life, especially when machining difficult-to-cut materials.
- Stable and robust 4-edge insert for efficient, high-feed milling.

# 415SD



## HIGH-FEED CUTTER

**S**

**415SD**

GAMP: 9°

GAMF: 5° – 6°

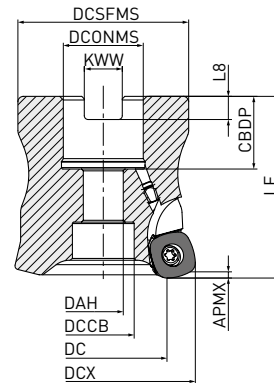
**1**

DCX	Set bolt	Geometry
Ø 50, Ø 52	HSC10035	
Ø 63, Ø 66	HSC12035	

*Right hand tool holder only.*

### ARBOR TYPE

Order number	Stock	APMX	DC	DCONMS	DCX	LF	RMPX	WT	ZEFP		Type	
415SD-050A04AR-E	●	2	33.4	22	50	50	3°	0.4	4		1	SDMT12
415SD-050A05AR-E	●	2	33.4	22	50	50	3°	0.4	5		1	
415SD-052A04AR-E	●	2	35.4	22	52	50	3°	0.4	4		1	
415SD-052A06AR-E	●	2	35.4	22	52	50	3°	0.4	6		1	
415SD-063X05AR-E	●	2	46.5	27	63	50	2°	0.7	5		1	
415SD-063X07AR-E	●	2	46.5	27	63	50	2°	0.7	7		1	
415SD-066X05AR-E	●	2	49.4	27	66	50	1.9°	0.7	5		1	
415SD-066X07AR-E	●	2	49.4	27	66	50	1.9°	0.7	7		1	

1/1

1. Please refer to page 91, for maximum depth of cut (APMX).

91

# 415SD



## HIGH-FEED CUTTER

### MOUNTING DIMENSIONS

Order number	CBDP	DAH	DCCB	DCONMS	DCSFMS	DCX	KWW	L8	Type
415SD-050A04AR-E	20	11	17	22	47	50	10.4	6.3	1
415SD-050A05AR-E	20	11	17	22	47	50	10.4	6.3	1
415SD-052A04AR-E	20	11	17	22	47	52	10.4	6.3	1
415SD-052A06AR-E	20	11	17	22	47	52	10.4	6.3	1
415SD-063X05AR-E	22	13	19	27	60	63	12.4	7.0	1
415SD-063X07AR-E	22	13	19	27	60	63	12.4	7.0	1
415SD-066X05AR-E	22	13	19	27	60	66	12.4	7.0	1
415SD-066X07AR-E	22	13	19	27	60	66	12.4	7.0	1





1/1

## INSERTS

Order number	Class	MP9130	IC	S	RE	Shape
SDMT125530ZEN-L MP9130	L	●	12.25	5.56	3.0	
SDMT125530ZEN-M MP9130	M	●	12.25	5.56	3.0	
SDMT125530ZSN-R MP9130	R	●	12.25	5.56	3.0	

1/1

## SPARE PARTS

Tool holder					
	Clamp screw	Flag wrench	Coolant nozzle	Standard L wrench	Anti-seize lubricant
415SD	TPS43	TIP15W-E	HSD04004H12	HKY20R	MK1KS

1. Clamp torque (N • m): TPS43 = 3.5

### COOLANT NOZZLES ARE AVAILABLE WITH VARYING DIAMETERS FOR ADJUSTING COOLANT PRESSURE

← Standard →

Nozzle Dia.	Ø 0.6mm	Ø 0.8mm	Ø 1.2mm	Ø 1.6mm
Order number	HSD04004H06	HSD04004H08	HSD04004H12	HSD04004H16

# 415SD

## RECOMMENDED CUTTING CONDITIONS

### CORRECTION FACTOR BY OVERHANG LENGTH







	DCX	Overhang length	Adjustment value		
			Vc	ap	fz
Arbor type	50 – 66	<2.5xDCX	100%	100%	100%
		3.0xDCX	85%	100%	90%
		4.0xDCX	80%	80%	80%
		5.0xDCX	75%	75%	60%
		6.0xDCX	70%	70%	40%

### CUTTING SPEED / WET CUTTING

Material	Properties	Cutting conditions	Grade	APMX	Vc		
					ae ≤ 0.5 DC	ae ≤ 0.75 DC	ae = DC
S Titanium alloy	—	● ● ✘	MP9130	≤ 1	55 [40 – 70]	50 [35 – 65]	45 [30 – 60]
			MP9130	≤ 2	55 [40 – 70]	50 [35 – 65]	45 [30 – 60]

1/1

### DEPTH OF CUT / FEED PER TOOTH

Material	Properties	Cutting conditions	Coolant	Grade	ae ≤ 0.5 DC		ae ≤ 0.75 DC		ae = DC				
					 ap	 fz	 ap	 fz	 ap	 fz			
S Titanium alloy	—	● ● ● ● ● ● ✘	●	MP9130	L	≤ 1	0.7 [0.5 – 0.9]	L	≤ 1	0.6 [0.4 – 0.7]	L	≤ 1	0.5 [0.3 – 0.6]
				MP9130	L	≤ 2	0.6 [0.4 – 0.8]	L	≤ 2	0.5 [0.3 – 0.6]	L	≤ 2	0.4 [0.2 – 0.5]
				MP9130	M	≤ 1	0.7 [0.5 – 0.9]	M	≤ 1	0.6 [0.4 – 0.7]	M	≤ 1	0.5 [0.3 – 0.6]
				MP9130	M	≤ 2	0.6 [0.4 – 0.8]	M	≤ 2	0.5 [0.3 – 0.6]	M	≤ 2	0.4 [0.2 – 0.5]
				MP9130	R	≤ 1	0.8 [0.6 – 1.0]	R	≤ 1	0.7 [0.4 – 0.9]	R	≤ 1	0.6 [0.4 – 0.8]
				MP9130	R	≤ 2	0.7 [0.5 – 0.9]	R	≤ 2	0.6 [0.3 – 0.8]	R	≤ 2	0.5 [0.3 – 0.7]
				MP9130	R	≤ 1	0.7 [0.5 – 0.9]	R	≤ 1	0.6 [0.4 – 0.7]	R	≤ 1	0.5 [0.3 – 0.6]
				MP9130	R	≤ 2	0.6 [0.4 – 0.8]	R	≤ 2	0.5 [0.3 – 0.6]	R	≤ 2	0.4 [0.2 – 0.5]

1/1

# 415SD

## MAXIMUM CAPACITIES BY MODE

### RAMPING

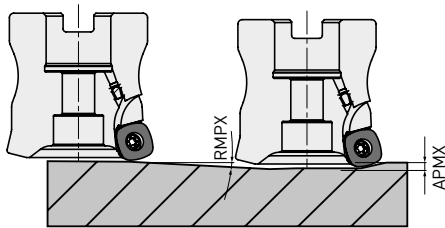

### HELICAL DRILLING

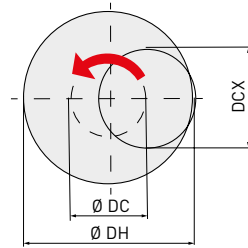

- How to derive a locus of the centre of the tool.

$$\text{Ø DC} = \text{Ø DH} - \text{DCX}$$

Locus of the centre of the tool      Desired hole diameter      Cutting Diameter Maximum

- For the depth of cut per pass, refer to the cutting conditions above for helical drilling.
- Set the machine spindle revolution so that the tool is rotating and cutting in a down cut direction.

- When ramping and helical cutting, please apply a lower feed (60 % of the calculated feed rate or less).
- The long chips generated can disperse, ensure that adequate safety precautions are taken.

Tool holder type	DCX	DC	APMX	Ramping		Helical drilling	
				RMPX	DH		
					Min.	Max.	
<b>ARBOR TYPE</b>							
41SD-050A04AR-E	50	33.4	2	3	84	97	
41SD-050A05AR-E	50	33.4	2	3	84	97	
41SD-052A04AR-E	52	35.4	2	3	88	101	
41SD-052A06AR-E	52	35.4	2	3	88	101	
41SD-063A05AR-E	63	46.5	2	2	110	123	
41SD-063A07AR-E	63	46.5	2	2	110	123	
41SD-066A05AR-E	66	49.4	2	1.9	116	129	
41SD-066A07AR-E	66	49.4	2	1.9	116	129	

## NOTE FOR PROGRAMMING

When using 415SD (MPLUS), please programme as an RE = 4.3 radius cutter. The approximate uncut portions for the programme are as follows.

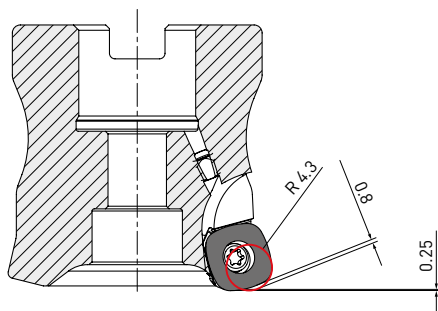

---

# ARM

---

MULTI-FUNCTIONAL HIGH FEED CUTTER  
FOR MOULD & DIE MACHINING

---



*Mplus...*

# ARM

## MULTI-FUNCTIONAL HIGH FEED CUTTER FOR MOULD & DIE MACHINING

ARM is a multifunctional high-performance cutter that provides process stability even at high feed rates. Its individual design as well as the advanced technical features promise high material removal rates combined with effective chip control.



### PRODUCT RANGE

#### ARM07:

- Arbor type: DC Ø 40 mm
- Shank type: DC Ø 16 – 32 mm
- Weldon type: DC Ø 16 – 32 mm
- Screw in type: DC Ø 16 – 42 mm

#### ARM09:

- Arbor type: DC Ø 40 – 66 mm
- Shank type: DC Ø 25 – 35 mm
- Weldon type: DC Ø 25 – 32 mm
- Screw in type: DC Ø 25 – 42 mm

#### ARM11:

- Arbor type: DC Ø 50 – 80 mm
- Shank type: DC Ø 32 mm
- Screw in type: DC Ø 32 – 35 mm

### APPLICATION

- Mould & die machining
- Roughing
- High feed cutting
- Face milling
- Copying
- Helical milling
- Pocketing



# ARM

## MULTI-FUNCTIONAL HIGH FEED CUTTER FOR MOULD & DIE MACHINING

### IDEAL FOR DEEP CAVITIES

- Internal coolant holes for air blow increases reliability due to effective chip disposal
- Ideal for high volume machining

### HIGH PRODUCTIVITY FOR ROUGHING APPLICATIONS

- Time saving when machining high hardness plastic injection moulds and forging dies
- Ideal for high feed machining path strategies

### COST EFFICIENT SOLUTION

- Economical 4 cutting edges
- Reinforced cutting edge geometry
- Versatile VP15TF grade for varied applications
- The micro-grain substrate and Miracle coating provide excellent welding resistance



### BENEFITS

- High metal removal rates
- Near nett shape material remaining
- Porcess stability and security
- High rigidity for high feed rates
- Long tool life in both soft and hard materials
- Economic cost/performance ratio due to 4 cutting edges
- For high volume roughing
- Proven performance for machining of plastic injection moulds
- Versatile range of cutters available





# ARM



## HIGH FEED MILLING CUTTER FOR MOULD & DIE

P M K H

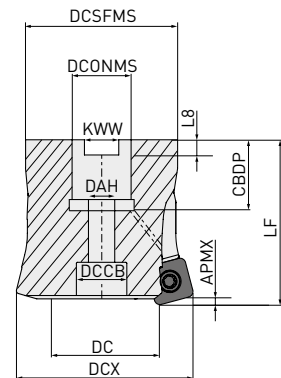

Right hand tool holder only.

### ARBOR TYPE

Order number	Stock	CICT	DCX	DC	LF	DCONMS	CDBP	DAH	DCSFMS	KWW	L8	APMX	DCCB		Inserts
ARM09-040A05R	●	5	40	22.9	40	16	18	9	38.5	8.4	5.6	1.4	12		SPMX094506
ARM09-042A05R	●	5	42	24.9	40	16	18	9	38.5	8.4	5.6	1.4	12		
ARM09-050A06R	●	6	50	33	40	22	20	11	49	10.4	6.3	1.4	17		
ARM09-052A07R	●	7	52	35	40	22	20	11	49	10.4	6.3	1.4	17		
ARM09-066A08R	●	8	66	48.9	50	27	22	13	60	12.4	7	1.4	19		
ARM11-050A05R	●	5	50	29.4	40	22	20	11	49	10.4	6.3	1.8	17		SPMX115506
ARM11-052A05R	●	5	52	31.4	40	22	20	11	49	10.4	6.3	1.8	17		
ARM11-063A06R	●	6	63	42.4	50	27	22	13	60	12.4	7	1.8	19		
ARM11-066A07R	●	7	66	45.4	50	27	22	13	60	12.4	7	1.8	19		
ARM11-080A08R	●	8	80	59.3	50	27	22	13	64	12.4	7	1.8	19		

1/1

100

## SET BOLT

DCX	Set bolt	Geometry
Ø 40-42	M8-C	
Ø 50-52	M10-C	
Ø 63-80	M12-C	

# ARM



## HIGH FEED MILLING CUTTER FOR MOULD & DIE

P M K H

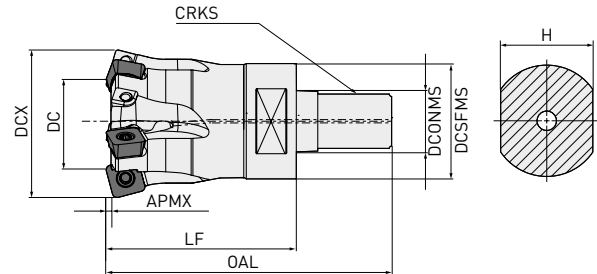

Right hand tool holder only.

### SCREW-IN TYPE

Order number	Stock	CICT	DCX	DC	LF	DCONMS	DCSFMS	OAL	H	CRKS	APMX		Inserts
ARM07R162AM08	●	2	16	4	23	8.5	14	40	12	M8	0.6	●	
ARM07R203AM10	●	3	20	7.5	30	10.5	18	48	15	M10	1.2	●	SPMX073505
ARM07R254AM12	●	4	25	12.5	35	12.5	21	56	19	M12	1.2	●	
ARM07R325AM16	●	5	32	19.5	43	17	29	66	22	M16	1.2	●	
ARM09R252AM12	●	2	25	8	35	12.5	21	56	19	M12	1.4	●	
ARM09R324AM16	●	4	32	15	43	17	29	66	22	M16	1.4	●	SPMX094506
ARM09R354AM16	●	4	35	17.9	43	17	29	66	22	M16	1.4	●	
ARM09R425AM16	●	5	42	24.9	43	17	29	66	22	M16	1.4	●	
ARM11R323AM16	●	3	32	11.7	43	17	29	66	22	M16	1.8	●	SPMX115506
ARM11R353AM16	●	3	35	14.6	43	17	29	66	22	M16	1.8	●	

1/1

100

# ARM



## HIGH FEED MILLING CUTTER FOR MOULD & DIE

P M K H

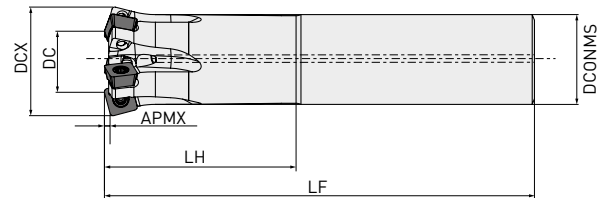

### CYLINDRICAL SHANK

Order number	Stock	CICT	DCX	DCONMS	DC	LF	LH	APMX		Inserts
ARM07R162SA16S	●	2	16	16	4	85	25	0.6	●	
ARM07R203SA20S	●	3	20	20	7.5	130	30	1.2	●	SPMX073505
ARM07R254SA25S	●	4	25	25	12.5	140	40	1.2	●	
ARM07R325SA32S	●	5	32	32	19.5	150	50	1.2	●	
ARM09R252SA25S	●	2	25	25	8	140	40	1.4	●	
ARM09R324SA32S	●	4	32	32	15	150	50	1.4	●	SPMX094506
ARM09R354SA32S	●	4	35	32	17.9	150	50	1.4	●	
ARM11R323SA32S	●	3	32	32	11.7	150	50	1.8	●	SPMX115506

1/1

100 

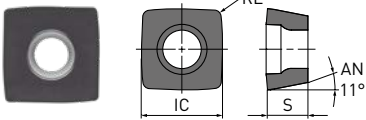

# INSERTS

Order number	Class	Honing*	VP15TF	VP10H	IC	S	RE	Shape
SPMX073505ZNEN-FT	M	E	●	●	7.0	3.5	0.5	
SPMX073505ZNSN-FT	M	S	●	●	7.0	3.5	0.5	
SPMX094506ZNEN-FT	M	E	●	●	9.7	4.4	0.6	
SPMX094506ZNSN-FT	M	S	●	●	9.7	4.4	0.6	
SPMX115506ZNEN-FT	M	E	●	●	11.6	5.4	0.6	
SPMX115506ZNSN-FT	M	S	●	●	11.6	5.4	0.6	

1/1

\* Honing:  
E: Round,  
S: Chamfer + Hone

# SPARE PARTS

Insert type	 <b>Clamp screw</b>	 <b>Wrench</b>
SPMX073505	TPS3	TIP10W
SPMX094506	TPS4 - C	TIP15W - C
SPMX115506	TPS43 - C	TIP15W - C

# ARM

## RECOMMENDED CUTTING CONDITIONS

Material	Hardness	Insert	Grade	Standard milling				High feed milling						
				Vc	fz	ap	ae	Vc	fz	ap	ae			
P	Mild steel	SPMX073505	VP15TF	170 (120 – 220)	1.0	0.3/0.8	100%/DC		200	1.0	0.4	100%/DC		
		SPMX094506			1.2	0.5/1	100%/DC			1.4	0.5	100%/DC		
		SPMX115506			1.5	0.8/1.5	100%/DC			1.4	0.8	100%/DC		
	Carbon steel Alloy steel	180 – 280HB	SPMX073505	VP15TF	150 (100 – 200)	0.9	0.3/0.5	100%/DC		200	100%/DC			
			SPMX094506			1	0.5/0.7	100%/DC			1.2	0.5	100%/DC	
			SPMX115506			1.2	0.6/1.5	100%/DC			1.2	0.8	100%/DC	
	Alloy tool steel	<350HB	SPMX073505	VP15TF	120 (80 – 150)	0.9	0.3/0.5	100%/DC		180	0.9	0.3	100%/DC	
			SPMX094506			1	0.5/0.7	100%/DC			1.2	0.4	100%/DC	
			SPMX115506			1.2	0.5/1	100%/DC			1.2	0.6	100%/DC	
Pre-hardened steel	35 – 45HRC	SPMX073505	VP15TF	100 (70 – 130)	0.75	0.3/0.5	100%/DC		150	0.75	0.3	100%/DC		
		SPMX094506			0.8	0.4/0.6	100%/DC			0.8	0.4	100%/DC		
		SPMX115506			0.8	0.4/0.8	100%/DC			0.8	0.5	100%/DC		
	Stainless steel	<200HB	SPMX073505	VP15TF	100 (60 – 120)	0.75	0.25/0.4	100%/DC		150	0.75	0.3	100%/DC	
			SPMX094506			0.8	0.4/0.6	100%/DC			0.8	0.4	100%/DC	
			SPMX115506			0.8	0.4/0.8	100%/DC			0.8	0.5	100%/DC	
M	PH, Duplex	SPMX073505	VP10H	120 (90 – 150)	0.75	0.25/0.4	100%/DC		150	0.75	0.3	100%/DC		
		SPMX094506			0.8	0.4/0.6	100%/DC			0.8	0.4	100%/DC		
		SPMX115506			0.8	0.4/0.8	100%/DC			0.8	0.5	100%/DC		
K	Gray cast iron	SPMX073505	VP15TF	100 (60 – 120)	0.3	0.4/0.8	100%/DC		–	–	–	–		
		SPMX094506			0.4	0.5/1	100%/DC			–	–	–		
		SPMX115506			0.4	0.6/1.5	100%/DC			–	–	–		
	Ductile cast iron	>200HB	SPMX073505	VP15TF	70 (50 – 90)	0.3	0.25/0.4	100%/DC		–	–	–	–	
			SPMX094506			0.4	0.3/0.5	100%/DC			–	–	–	
			SPMX115506			0.4	0.4/0.8	100%/DC			–	–	–	
H	Gray cast iron	SPMX073505	VP15TF	150 (100 – 200)	1.0	0.3/0.6	100%/DC		–	–	–	–		
		SPMX094506			1.2	0.5/0.8	100%/DC			–	–	–		
		SPMX115506			1.2	0.6/1.5	100%/DC			–	–	–		
	Ductile cast iron	<450MPa	SPMX073505	VP15TF	120 (80 – 160)	0.8	0.25/0.5	100%/DC		–	–	–	–	
			SPMX094506			1	0.4/0.6	100%/DC			–	–	–	
			SPMX115506			1	0.5/0.8	100%/DC			–	–	–	
Hardened steel	40 – 55HRC	SPMX073505	VP15TF	70 (50 – 90)	0.5	0.25/0.4	100%/DC		120	0.5	0.25	100%/DC		
		SPMX094506			0.6	0.3/0.5	100%/DC			0.6	0.3	100%/DC		
		SPMX115506			0.6	0.3/0.6	100%/DC			0.6	0.4	100%/DC		
	Alloy tool steel	40 – 55HRC	SPMX073505	VP10H	90 (70 – 120)	0.5	0.25/0.4	100%/DC		120	0.5	0.25	100%/DC	
			SPMX094506			0.6	0.3/0.5	100%/DC			0.6	0.3	100%/DC	
			SPMX115506			0.6	0.3/0.6	100%/DC			0.6	0.4	100%/DC	

1/1

### NOTE FOR PROGRAMMING

When using ARM cutters, please program as an RE radius cutter.  
The approximate uncut portions for the program are as follows:

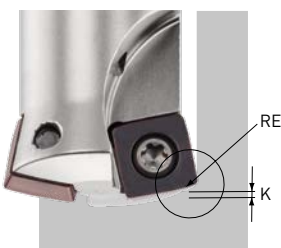

Insert size	RE	K
07	1.7	0.82
09	2.3	1.6
11	2.695	2.1

---

# SIDE AND FACE MILLING CUTTER SERIES

---

SIDE AND FACE MACHINING WITH LOW CUTTING  
RESISTANCE VERTICAL MOUNT DOUBLE-SIDED INSERTS  
FOR DCV SERIES

---

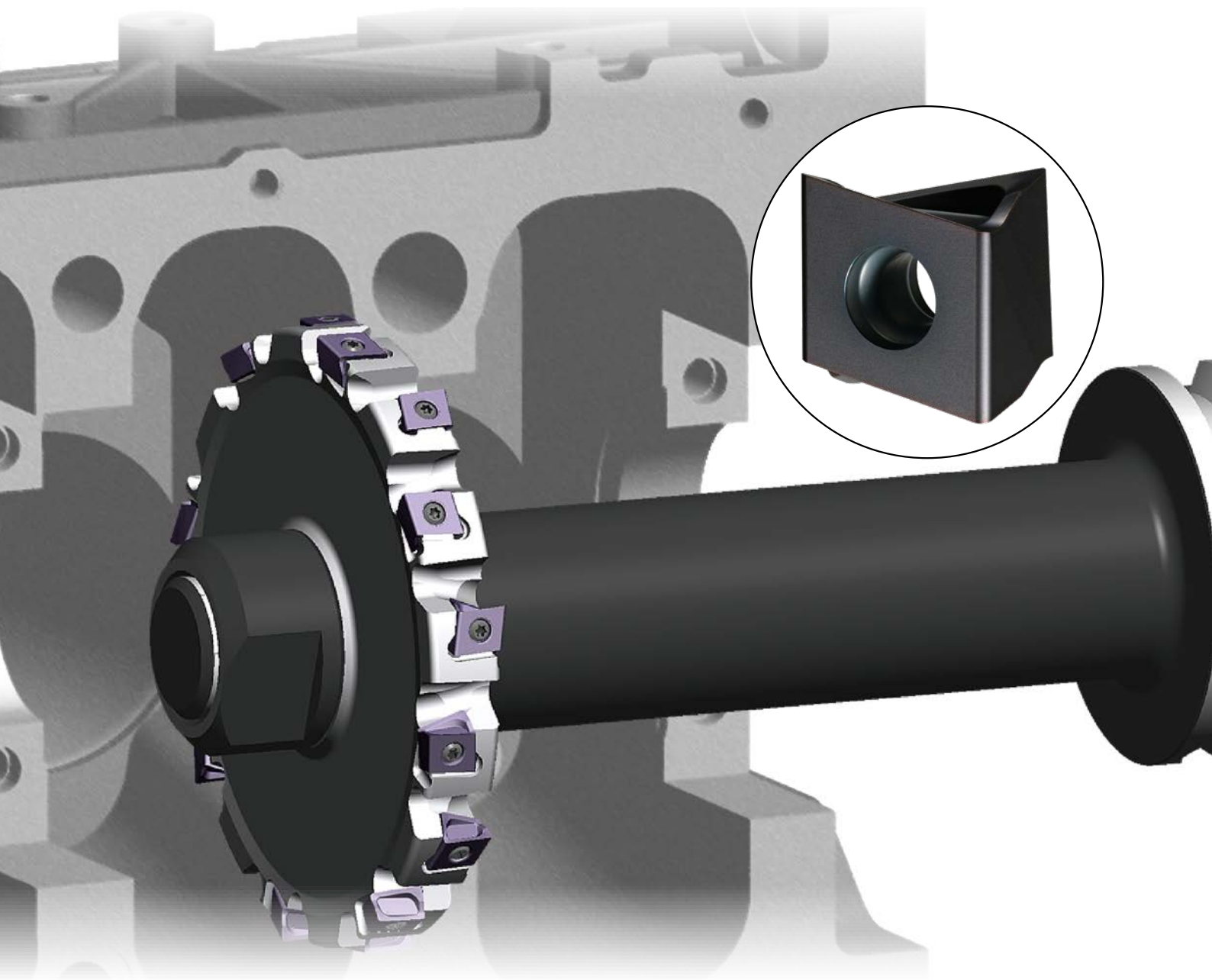

*M*plus...

# DCV3 / DCV4 / DCV5

## EXCHANGEABLE INSERTS

### ECONOMICAL INSERT DESIGN

Tangential type insert with 4 cutting edges.

### SECURE CLAMPING

Special seating surfaces ensure all different insert radius sizes are securely clamped.

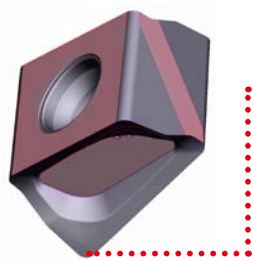

Corner radius R 0.4 mm

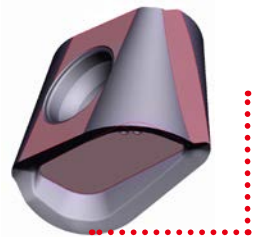

Corner radius R 4.0 mm for DCV3  
 Corner radius R 5.0 mm for DCV4  
 Corner radius R 7.0 mm for DCV5

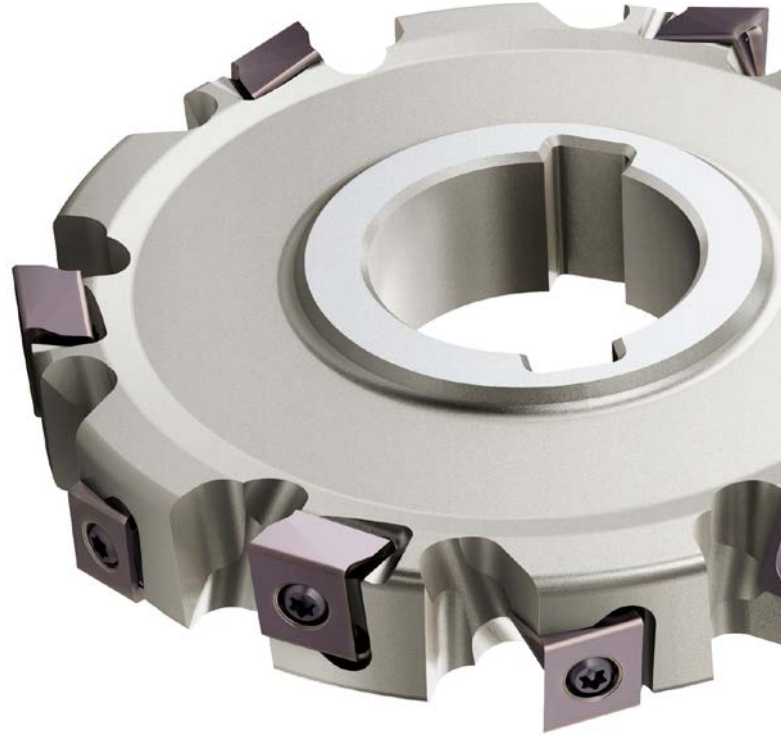

Cutter body with inserts: GAMF: + 8° GAMP: + 3°

### LOW CUTTING RESISTANCE INSERT → PREFERRED SHARPNESS

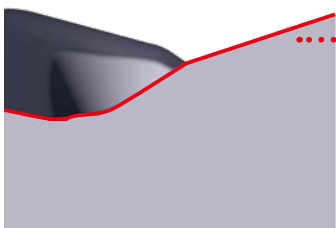

Tough cutting edge  
 (Convex curve)

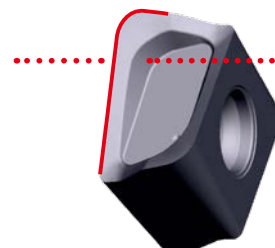

Double-phased helical  
 rake angles

## HIGH PRECISION CORNER RADIUS

PRECISION INSERTS FOR FORMING ACCURATE CORNER RADII IN THE WORKPIECE.

R 0.4 – R 3.0 mm

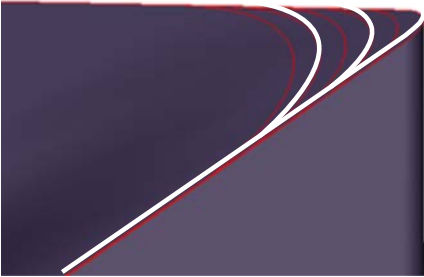

R 3.0 – R 7.0 mm

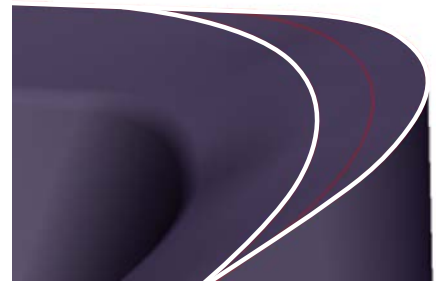

### CONSISTENT GEOMETRY

Cutting width and diameter do not change even when different corner radius inserts are used.

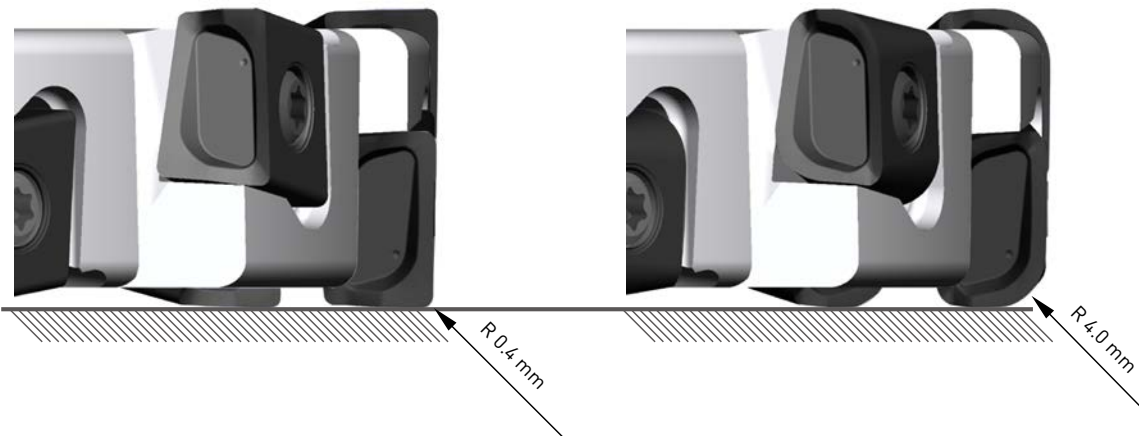

### LARGE VARIETY OF CORNER RADII AVAILABLE

DCV3 = R 0.4 – R 4.0 mm

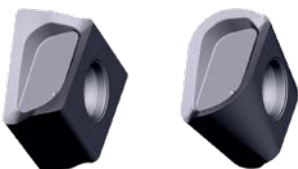

DCV4 = R 0.4 – R 5.0 mm

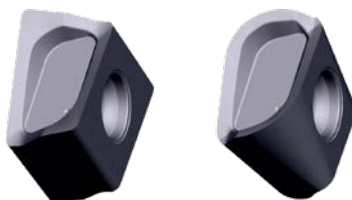

DCV5 = R 0.4 – R 7.0 mm

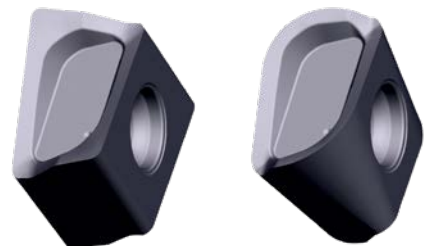



# DCV3



P K

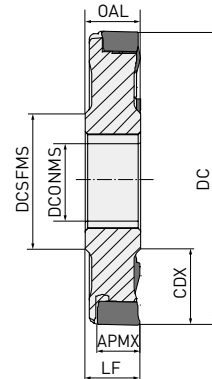
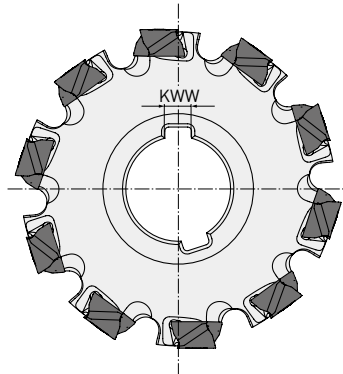

Max. APMX: 8.6 mm

## HALF SIDE

DC	ZNF	LF = OAL	CDX	DCONMS	DCSFMS	KWW		
80 - 99.9	8	≥12	20.0	27	40	7	—	LNGU09
100 - 124.9	10		27.0	32	46	8	—	
125 - 160.0	12		35.0	40	55	10	—	

1/1

115

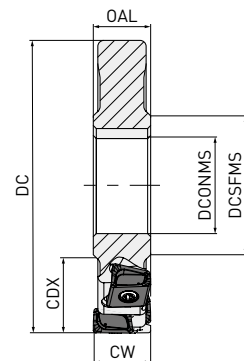
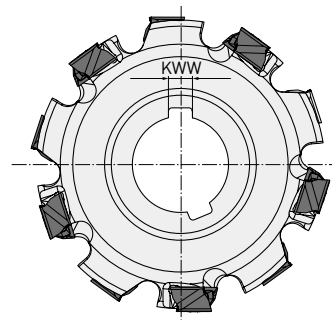

Largest width CW: 17.2 mm

## FULL SIDE

DC	ZNF	ZNP	LF = OAL	CW	CDX	DCONMS	DCSFMS	KWW		
80 - 99.9	4	8	≥12	12-17.2	20.0	27	40	7	—	LNGU09
100 - 124.9	5	10		12-17.2	27.0	32	46	8	—	
125 - 160.0	6	12		12-17.2	35.0	40	55	10	—	

1/1

1. Multi level designs available for each size. Please contact our technical department (MMC Hartmetall GmbH - special@mmchg.de) for details of any geometry not shown.

115

# DCV3



P K

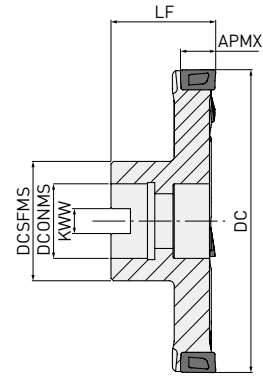
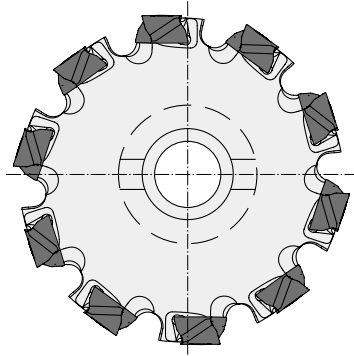
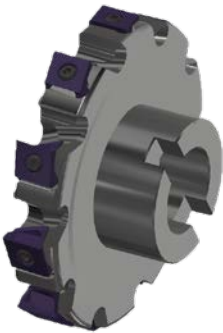

Max. APMX: 8.6 mm

## HALF SIDE ARBOR

DC	ZEFP	LF	CDX	DCONMS	DCSFMS	KWW		
80 - 99.9	8	50	20.0	27	40	12.4	—	LNGU09
100 - 124.9	10	60	27.0	32	46	14.4	—	
125 - 160.0	12	60	35.0	40	55	16.4	—	

1/1

115

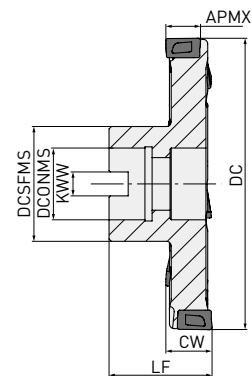
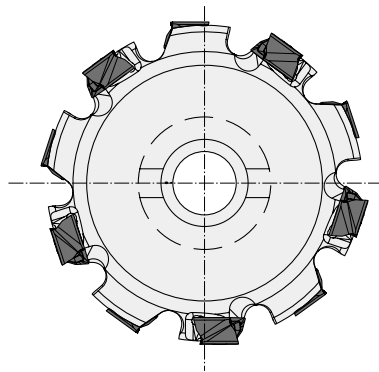

Largest width CW: 17.2 mm

## FULL SIDE ARBOR

DC	ZEFP	LF	CW	CDX	DCONMS	DCSFMS	KWW		
80 - 99.9	8	50	12-17.2	20.0	27	40	12.4	—	LNGU09
100 - 124.9	10	60	12-17.2	27.0	32	46	14.4	—	
125 - 160.0	12	60	12-17.2	35.0	40	55	16.4	—	



1/1

1. Multi level designs available for each size. Please contact our technical department (MMC Hartmetall GmbH - special@mmchg.de) for details of any geometry not shown.

115

# DCV3

## SPARE PARTS

Tool holder type		TQ (Nm)		
	Clamp screw	Clamp torque	Wrench	Anti-seize lubricant
DCV3 LNGU090600PNEOM	TS304	1.5	TKY08W	MK1KS

## INSERT

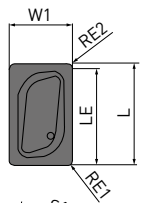
Order number	VP15TF	Hand	Class	Honing	L	LE	S	S10	RE1	W1	Shape	Geometry
												Right hand insert shown
LNGU090604PNER-M	●	R	G	E	9	8.6	6	8.5	0.4	6		
LNGU090608PNER-M	●	R	G	E	9	8.6	6	8.5	0.8	6		
LNGU090612PNER-M	●	R	G	E	9	8.6	6	8.5	1.2	6		
LNGU090616PNER-M	●	R	G	E	9	8.6	6	8.5	1.6	6		
LNGU090620PNER-M	●	R	G	E	9	8.6	6	8.5	2	6		
LNGU090624PNER-M	●	R	G	E	9	8.6	6	8.5	2.4	6		
LNGU090630PNER-M	●	R	G	E	9	8.6	6	8.5	3	6		
LNGU090640PNER-M	●	R	G	E	9	8.6	6	8.5	4	6		
LNGU090604PNEL-M	●	L	G	E	9	8.6	6	8.5	0.4	6		
LNGU090608PNEL-M	●	L	G	E	9	8.6	6	8.5	0.8	6		
LNGU090612PNEL-M	●	L	G	E	9	8.6	6	8.5	1.2	6		
LNGU090616PNEL-M	●	L	G	E	9	8.6	6	8.5	1.6	6		
LNGU090620PNEL-M	●	L	G	E	9	8.6	6	8.5	2	6		
LNGU090624PNEL-M	●	L	G	E	9	8.6	6	8.5	2.4	6		
LNGU090630PNEL-M	●	L	G	E	9	8.6	6	8.5	3	6		
LNGU090640PNEL-M	●	L	G	E	9	8.6	6	8.5	4	6		

1/1

[10 inserts in one case]

# DCV4



**P** **K**

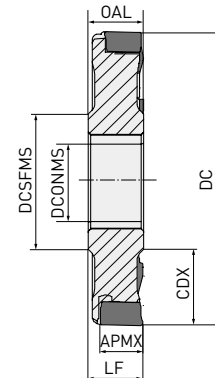
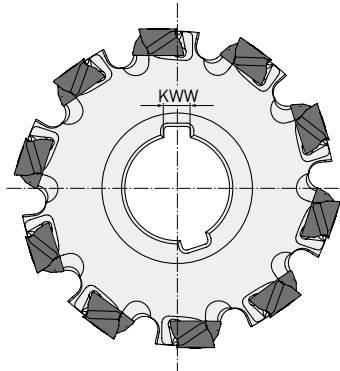

Max. APMX: RE1 < 3.0 mm 12.2 mm  
RE1 > 3.0 mm 11.4 mm

## HALF SIDE

DC	ZEFP	LF = OAL	CDX	DCONMS	DCSFMS	KWW		
80 - 99.9	8	18	20.0	27	40	7	—	LNGU13
100 - 124.9	10		27.0	32	46	8	—	
125 - 159.9	12		35.0	40	55	10	—	
160 - 200	14		52.5	40	55	10	—	

1/1

115

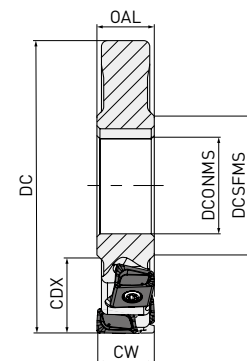
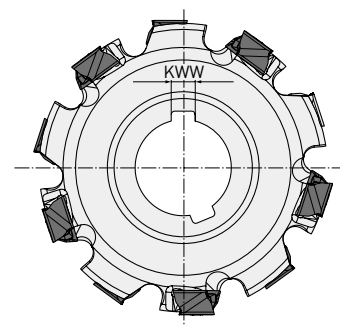

Largest width CW: 24 mm

## FULL SIDE

DC	ZEFP	CW	CDX	DCONMS	DCSFMS	KWW		
80 - 99.9	4	18-24	20.0	27	40	7	—	LNGU13
100 - 124.9	5	18-24	27.0	32	46	8	—	
125 - 159.9	6	18-24	35.0	40	55	10	—	
160 - 200	7	18-24	52.5	40	55	10	—	

1/1

1. Multi level designs available for each size. Please contact our technical department (MMC Hartmetall GmbH - special@mmchg.de) for details of any geometry not shown.

115

# DCV4



P

K

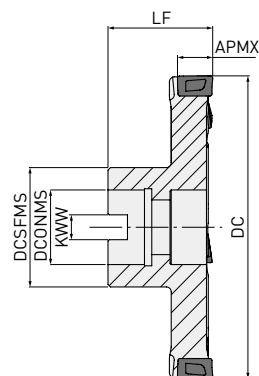
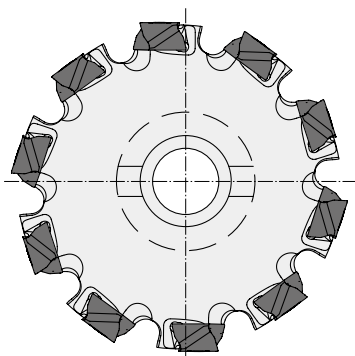

## HALF SIDE ARBOR

Max. APMX: RE1 < 3.0 mm 12.2 mm  
RE1 > 3.0 mm 11.4 mm

DC	ZEFP	LF	CDX	DCONMS	DCSFMS	KWW		
80 - 99.9	8 - 10	50	20	27	40	12.4	—	LNGU13
100 - 124.9	10 - 12	60	27	32	46	14.4	—	
125 - 159.9	12 - 14	60	35	40	55	16.4	—	
160 - 200	14 - 20	70	52.5	40	55	16.4	—	

1/1

115

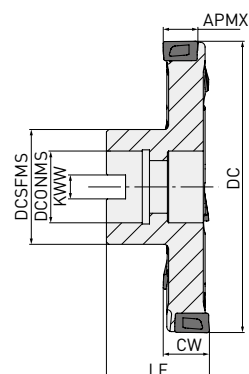
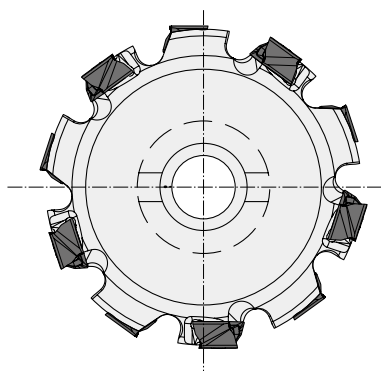

Largest width CW: 24 mm

## FULL SIDE ARBOR

DC	ZEFP	LF	CW	CDX	DCONMS	DCSFMS	KWW		
80 - 99.9	8 - 10	50	18-24	20	27	40	12.4	—	LNGU13
100 - 124.9	10 - 12	60	18-24	27	32	46	14.4	—	
125 - 159.9	12 - 14	60	18-24	35	40	55	16.4	—	
160 - 200	14 - 20	70	18-24	52.5	40	55	16.4	—	

1/1

1. Multi level designs available for each size. Please contact our technical department (MMC Hartmetall GmbH - special@mmchg.de) for details of any geometry not shown.

115

# DCV4

## SPARE PARTS

Tool holder type		TQ (Nm)		
	Clamp screw	Clamp torque	Wrench	Anti-seize lubricant
DCV4 LNGU13080PNE	TS406	3.5	TKY15T	MK1KS

## INSERT

Order number	MP6120 VP15TF	Hand	Class	Honing	L	LE	S	S10	RE1	RE2	W1	Shape	Geometry
													Right hand insert shown
LNGU130804PNER-M	●	R	G	E	13.0	12.2	8.0	11.0	0.4	0.8	8.0		
LNGU130804PNEL-M	●	L	G	E	13.0	12.2	8.0	11.0	0.4	0.8	8.0		
LNGU130808PNER-M	●	R	G	E	13.0	12.2	8.0	11.0	0.8	0.8	8.0		
LNGU130808PNEL-M	●	L	G	E	13.0	12.2	8.0	11.0	0.8	0.8	8.0		
LNGU130812PNER-M	●	R	G	E	13.0	12.2	8.0	11.0	1.2	0.8	8.0		
LNGU130812PNEL-M	●	L	G	E	13.0	12.2	8.0	11.0	1.2	0.8	8.0		
LNGU130816PNER-M	●	R	G	E	13.0	12.2	8.0	11.0	1.6	0.8	8.0		
LNGU130816PNEL-M	●	L	G	E	13.0	12.2	8.0	11.0	1.6	0.8	8.0		
LNGU130820PNER-M	●	R	G	E	13.0	12.2	8.0	11.0	2.0	0.8	8.0		
LNGU130820PNEL-M	●	L	G	E	13.0	12.2	8.0	11.0	2.0	0.8	8.0		
LNGU130824PNER-M	●	R	G	E	13.0	12.2	8.0	11.0	2.4	0.8	8.0		
LNGU130824PNEL-M	●	L	G	E	13.0	12.2	8.0	11.0	2.4	0.8	8.0		
LNGU130830PNER-M	●	R	G	E	13.0	11.4	8.0	11.0	3.0	1.6	8.0		
LNGU130830PNEL-M	●	L	G	E	13.0	11.4	8.0	11.0	3.0	1.6	8.0		
LNGU130840PNER-M	●	R	G	E	13.0	11.4	8.0	11.0	4.0	1.6	8.0		
LNGU130840PNEL-M	●	L	G	E	13.0	11.4	8.0	11.0	4.0	1.6	8.0		
LNGU130850PNER-M	●	R	G	E	13.0	11.4	8.0	11.0	5.0	1.6	8.0		
LNGU130850PNEL-M	●	L	G	E	13.0	11.4	8.0	11.0	5.0	1.6	8.0		
LNGU130804PNER-R	●	R	G	E	13.0	12.2	8.0	11.0	0.4	0.8	8.0		
LNGU130804PNEL-R	●	L	G	E	13.0	12.2	8.0	11.0	0.4	0.8	8.0		
LNGU130808PNER-R	●	R	G	E	13.0	12.2	8.0	11.0	0.8	0.8	8.0		
LNGU130808PNEL-R	●	L	G	E	13.0	12.2	8.0	11.0	0.8	0.8	8.0		
LNGU130812PNER-R	●	R	G	E	13.0	12.2	8.0	11.0	1.2	0.8	8.0		
LNGU130812PNEL-R	●	L	G	E	13.0	12.2	8.0	11.0	1.2	0.8	8.0		
LNGU130816PNER-R	●	R	G	E	13.0	12.2	8.0	11.0	1.6	0.8	8.0		
LNGU130816PNEL-R	●	L	G	E	13.0	12.2	8.0	11.0	1.6	0.8	8.0		
LNGU130820PNER-R	●	R	G	E	13.0	12.2	8.0	11.0	2.0	0.8	8.0		
LNGU130820PNEL-R	●	L	G	E	13.0	12.2	8.0	11.0	2.0	0.8	8.0		
LNGU130824PNER-R	●	R	G	E	13.0	12.2	8.0	11.0	2.4	0.8	8.0		
LNGU130824PNEL-R	●	L	G	E	13.0	12.2	8.0	11.0	2.4	0.8	8.0		
LNGU130830PNER-R	●	R	G	E	13.0	11.4	8.0	11.0	3.0	1.6	8.0		
LNGU130830PNEL-R	●	L	G	E	13.0	11.4	8.0	11.0	3.0	1.6	8.0		
LNGU130840PNER-R	●	R	G	E	13.0	11.4	8.0	11.0	4.0	1.6	8.0		
LNGU130840PNEL-R	●	L	G	E	13.0	11.4	8.0	11.0	4.0	1.6	8.0		
LNGU130850PNER-R	●	R	G	E	13.0	11.4	8.0	11.0	5.0	1.6	8.0		
LNGU130850PNEL-R	●	L	G	E	13.0	11.4	8.0	11.0	5.0	1.6	8.0		

1/1

(10 inserts in one case)

● : Inventory maintained. □ : Produced to order only.

# DCV5



P K

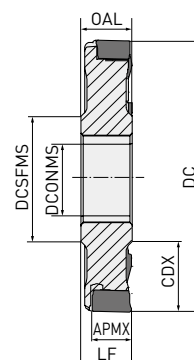
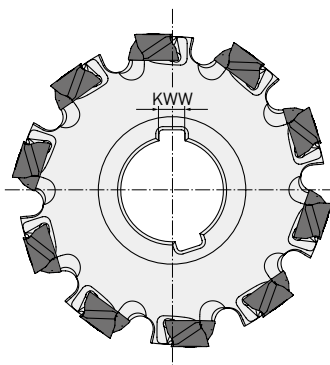

Max. APMX: RE1 < 3.0 mm 16.2 mm  
RE1 > 3.0 mm 15.4 mm

## HALF SIDE

DC	ZEFP	LF = OAL	CDX	DCONMS	DCSFMS	KWW		
100 – 124.9	8	23	27.0	32	46	8	—	LNGU17
125 – 159.9	10		35.0	40	55	10	—	
160 – 199.9	12		52.5	40	55	10	—	
200 – 250	16		65.0	50	70	12	—	

1/1

115

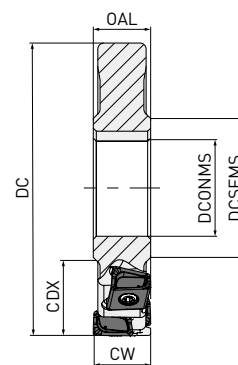
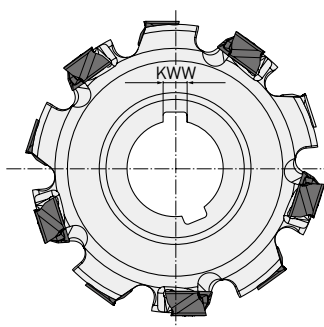

Largest width CW: 32 mm

## FULL SIDE

DC	ZEFP	CW	CDX	DCONMS	DCSFMS	KWW		
100 – 124.9	8	23 – 32	27.0	32	46	8	—	LNGU17
125 – 159.9	10		35.0	40	55	10	—	
160 – 199.9	12		52.5	40	55	10	—	
200 – 250	16		65.0	50	70	12	—	

1/1

1. Multi level designs available for each size. Please contact our technical department (MMC Hartmetall GmbH - special@mmchg.de) for details of any geometry not shown.

115

# DCV5



P K

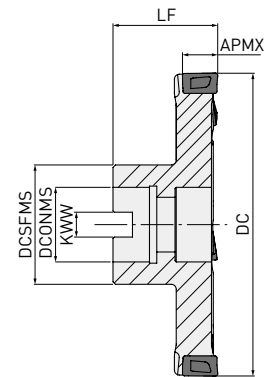
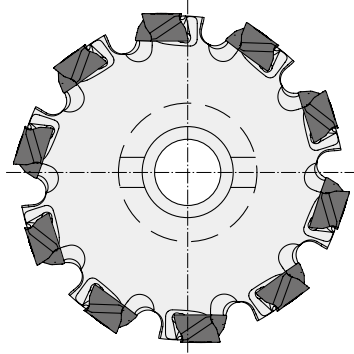

Max. APMX: RE1 < 3.0 mm 16.2 mm  
RE1 > 3.0 mm 15.4 mm

## HALF SIDE ARBOR

DC	ZEFP	LF	CDX	DCONMS	DCSFMS	KWW		
100 – 124.9	8 – 10	50	27	32	46	14.4	—	LNGU17
125 – 159.9	10 – 12	60	35	40	55	16.4	—	
160 – 199.9	12 – 14	60	52.5	40	55	16.4	—	
200 – 250.0	14 – 20	70	65	40	70	16.4	—	

1/1

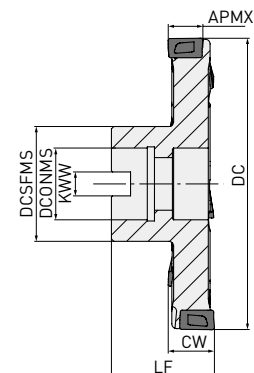
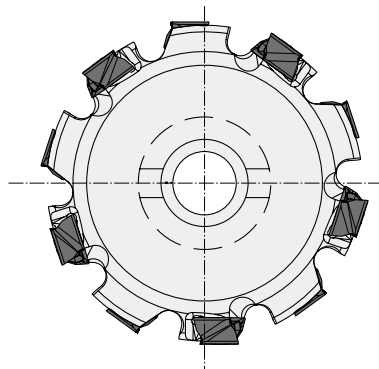

Largest width CW: 32 mm

## FULL SIDE ARBOR

DC	ZEFP	LF	CW	CDX	DCONMS	DCSFMS	KWW		
100 – 124.9	8 – 10	60	23 – 32	27	32	46	14.4	—	LNGU17
125 – 159.9	10 – 12	60		35	40	55	16.4	—	
160 – 199.9	12 – 14	70		52.5	40	55	16.4	—	
200 – 250.0	14 – 20	70		65	40	70	16.4	—	



1/1

1. Multi level designs available for each size. Please contact our technical department (MMC Hartmetall GmbH - special@mmchg.de) for details of any geometry not shown.



# DCV5

## SPARE PARTS

Tool holder type		TQ (Nm)		
	Clamp screw	Clamp torque	Wrench	Anti-seize lubricant
DCV5 LNGU17100PNER	TS53	7.5	TKY25T	MK1KS

## INSERT

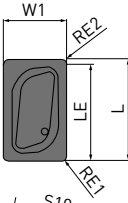
Order number	MP6120	VP15TF	Hand	Class	Honing	L	LE	S	S10	RE1	RE2	W1	D1	Shape	Geometry
															Right hand insert shown
LNGU171004PNER-R	●	●	R	G	E	17.0	16.2	10.0	13.0	0.4	0.8	10.0	5.5		
LNGU171004PNEL-R	●	●	L	G	E	17.0	16.2	10.0	13.0	0.4	0.8	10.0	5.5		
LNGU171008PNER-R	●	●	R	G	E	17.0	16.2	10.0	13.0	0.8	0.8	10.0	5.5		
LNGU171008PNEL-R	●	●	L	G	E	17.0	16.2	10.0	13.0	0.8	0.8	10.0	5.5		
LNGU171012PNER-R	●	●	R	G	E	17.0	16.2	10.0	13.0	1.2	0.8	10.0	5.5		
LNGU171012PNEL-R	●	●	L	G	E	17.0	16.2	10.0	13.0	1.2	0.8	10.0	5.5		
LNGU171016PNER-R	●	●	R	G	E	17.0	16.2	10.0	13.0	1.6	0.8	10.0	5.5		
LNGU171016PNEL-R	●	●	L	G	E	17.0	16.2	10.0	13.0	1.6	0.8	10.0	5.5		
LNGU171020PNER-R	●	●	R	G	E	17.0	16.2	10.0	13.0	2.0	0.8	10.0	5.5		
LNGU171020PNEL-R	●	●	L	G	E	17.0	16.2	10.0	13.0	2.0	0.8	10.0	5.5		
LNGU171024PNER-R	●	●	R	G	E	17.0	16.2	10.0	13.0	2.4	0.8	10.0	5.5		
LNGU171024PNEL-R	●	●	L	G	E	17.0	16.2	10.0	13.0	2.4	0.8	10.0	5.5		
LNGU171030PNER-R	●	●	R	G	E	17.0	15.4	10.0	13.0	3.0	1.6	10.0	5.5		
LNGU171030PNEL-R	●	●	L	G	E	17.0	15.4	10.0	13.0	3.0	1.6	10.0	5.5		
LNGU171040PNER-R	●	●	R	G	E	17.0	15.4	10.0	13.0	4.0	1.6	10.0	5.5		
LNGU171040PNEL-R	●	●	L	G	E	17.0	15.4	10.0	13.0	4.0	1.6	10.0	5.5		
LNGU171050PNER-R	●	●	R	G	E	17.0	15.4	10.0	13.0	5.0	1.6	10.0	5.5		
LNGU171050PNEL-R	●	●	L	G	E	17.0	15.4	10.0	13.0	5.0	1.6	10.0	5.5		
LNGU171060PNER-R	●	●	R	G	E	17.0	15.4	10.0	13.0	6.0	1.6	10.0	5.5		
LNGU171060PNEL-R	●	●	L	G	E	17.0	15.4	10.0	13.0	6.0	1.6	10.0	5.5		
LNGU171070PNER-R	●	●	R	G	E	17.0	15.4	10.0	13.0	7.0	1.6	10.0	5.5		
LNGU171070PNEL-R	●	●	L	G	E	17.0	15.4	10.0	13.0	7.0	1.6	10.0	5.5		

1/1

[10 inserts in one case]

## APPLICATION EXAMPLES

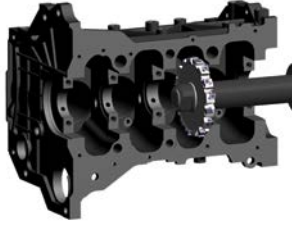
Tool	DCV4 Ø 300 mm	DCV4 Ø 160 mm
Insert (Grade)	LNGU130804PNER-M (VP15TF)	LNGU130804PNER-M (VP15TF)
	Brake caliper (DIN GGG40.3)	Cylinder block (DIN GG25)
Workpiece		
n (min <sup>-1</sup> )	120	500
Vc (m/min)	113	201
fz (mm/t.)	0.09 – 0.24	0.14
Vf (mm/min)	150 – 400	500
ap (mm)	1.0 – 2.0	1.0
Cutting mode	Dry cutting	Dry cutting
Machine	Machining centre	Horizontal
Results	Approximately 2 x longer tool life than conventional products. Excellent dimensional accuracy and surface finish. Improved machining efficiency gave a 30 % reduction in tooling costs.	1.5 x better machining efficiency than conventional products. Approximately double tool life. Stable cutting with minimal sound and provided a good surface finish. Improved machining efficiency and longer tool life.

1. The above application examples are customer's application examples, and can differ from the recommended conditions.

## UNIQUE SIDE CUTTER SERIES

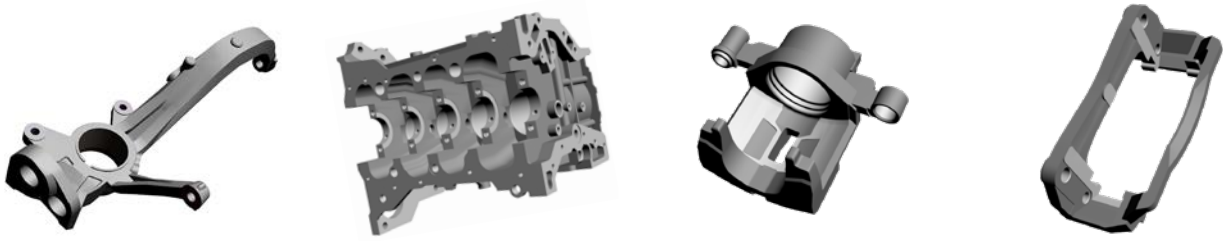

Taking advantage of the latest technology, materials and cutter geometry.

### CLASSIFIED

	DCV3	DCV4	DCV5
<b>Material</b>	P K	P K	P K
Low cutting resistance	◎	◎	◎
Toughness	◎	◎	◎
Insert shape		Vertical	Vertical
ZNF		Double sided insert	Double sided insert
ZNP	4	4	4
Half side Max. depth of cut APMX	RE < 4.0 mm 8.6 mm RE ≥ 3.0mm 11.4 mm	RE < 3.0 mm 12.2 mm RE ≥ 3.0mm 11.4 mm	RE < 3.0 mm 16.2 mm RE ≥ 3.0 mm 15.4 mm
Full side Max. cutting dia DC	Ø 300 mm	Ø 400 mm	Ø 660 mm

# DCV3 / DCV4 / DCV5

## RECOMMENDED CUTTING CONDITIONS

### SHOULDER MILLING

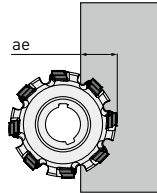
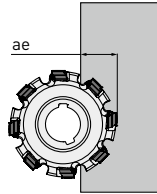
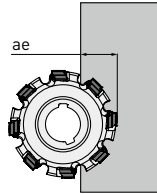
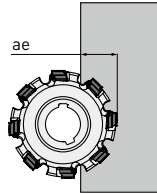
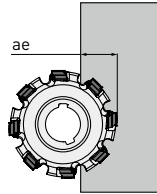
Material	Hardness	Grade	Vc	ap	ae	fz	Cutting mode	
P Steel	≤180HB	MP6120 VP15TF	150 (130 – 180)	≤APMX	<10%	0.10 (0.08 – 0.15)		
					<30%			
					≤50%			
				≤2.0	≤50%			0.12 (0.08 – 0.20)
				≤4.0	<10%			0.12 (0.08 – 0.20)
P Carbon steel/ Alloy steel	180 – 280HB	MP6120 VP15TF	150 (130 – 180)	≤4.0	<10%	0.10 (0.08 – 0.15)		
				≤APMX	<10%	0.10 (0.08 – 0.15)		
				≤APMX	≤50%	0.10 (0.08 – 0.12)		
				≤2.0	≤50%	0.12 (0.08 – 0.20)		
				≤4.0	<10%	0.12 (0.08 – 0.20)		
K Cast iron	Tensile strength ≤ 350MPa	VP15TF	150 (130 – 180)	≤4.0	<10%	0.10 (0.08 – 0.15)		
				≤APMX	<10%	0.10 (0.08 – 0.15)		
				≤APMX	≤50%	0.10 (0.08 – 0.12)		
				≤2.0	≤50%	0.12 (0.08 – 0.20)		
				≤4.0	<10%	0.12 (0.08 – 0.20)		
K Gray cast iron	Tensile strength ≤ 450MPa	VP15TF	130 (110 – 160)	≤4.0	<10%	0.10 (0.08 – 0.15)		
				≤APMX	<10%	0.10 (0.08 – 0.15)		
				≤APMX	≤50%	0.10 (0.08 – 0.12)		
				≤2.0	≤50%	0.12 (0.08 – 0.20)		
				≤4.0	<10%	0.12 (0.08 – 0.20)		
K Ductile cast iron	Tensile strength ≤ 800MPa	VP15TF	130 (110 – 160)	≤4.0	<10%	0.10 (0.08 – 0.15)		
				≤APMX	<10%	0.10 (0.08 – 0.15)		
				≤APMX	≤50%	0.10 (0.08 – 0.12)		
				≤2.0	≤50%	0.12 (0.08 – 0.20)		
				≤4.0	<10%	0.12 (0.08 – 0.20)		

1/1

### FACE MILLING

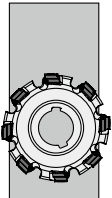
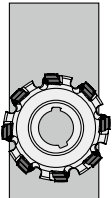
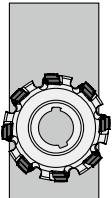
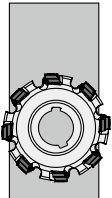
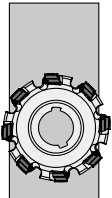
Material	Hardness	Grade	Vc	ap	fz	Cutting mode
P Steel	≤180HB	MP6120 VP15TF	150 (130 – 180)	≤APMX	0.10 (0.08 – 0.15)	
				≤2.0	0.12 (0.08 – 0.20)	
				≤4.0	0.10 (0.08 – 0.15)	
P Carbon steel/ Alloy steel	180 – 280HB	MP6120 VP15TF	150 (130 – 180)	≤APMX	0.10 (0.08 – 0.12)	
				≤2.0	0.12 (0.08 – 0.20)	
				≤4.0	0.10 (0.08 – 0.15)	
K Cast iron	Tensile strength ≤ 350MPa	VP15TF	150 (130 – 180)	≤APMX	0.10 (0.08 – 0.12)	
				≤2.0	0.12 (0.08 – 0.20)	
				≤4.0	0.10 (0.08 – 0.15)	
K Gray cast iron	Tensile strength ≤ 450MPa	VP15TF	150 (130 – 180)	≤APMX	0.10 (0.08 – 0.12)	
				≤2.0	0.12 (0.08 – 0.20)	
				≤4.0	0.10 (0.08 – 0.15)	
K Ductile cast iron	Tensile strength ≤ 800MPa	VP15TF	130 (110 – 160)	≤APMX	0.10 (0.08 – 0.12)	
				≤2.0	0.12 (0.08 – 0.20)	
				≤4.0	0.10 (0.08 – 0.15)	

1/1

---

# LSE445

---

GENERAL FACE MILLING SERIES WITH 20° POSITIVE  
INSERTS FOR RELIABLE AND EFFICIENT MACHINING

---



*M*plus...

# LSE445



## 45° FACE MILLING GENERAL CUTTING



CH: 45°  
A.R: +19°      T: +13°  
RR: -2°      I: +15°

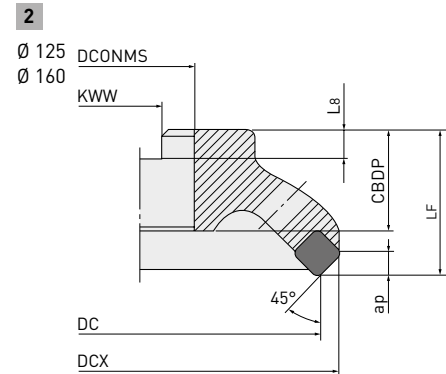
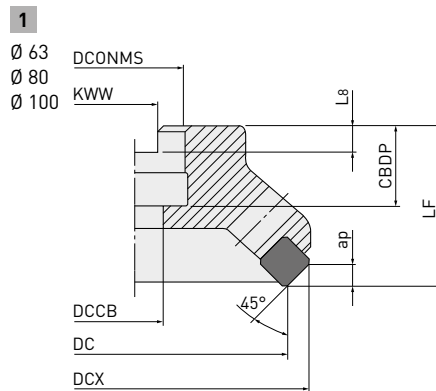

### ARBOR TYPE

Order number	Stock		ZEFP	DC	DCX	LF	DCONMS	CBDP	DCCB	KWW	L8	WT	APMX	Type	
	R	L													
LSE445-063A05R/L-E	●	□	5	63	76.5	40	22	20	11	10.4	6.4	0.8	5.5	—	1
LSE445-080A06R/L-E	●	□	6	80	93.5	50	27	22	13.5	12.4	7.0	1.0	5.5	—	1
LSE445-100A07R/L-E	●	□	7	100	113.5	50	32	25	17.5	14.4	8.0	1.4	5.5	—	1
LSE445-125B09R/L-E	□	□	9	125	138.5	50	40	32	—	16.4	9.0	2.0	5.5	—	2
LSE445-160B11R/L-E	□	□	11	160	173.5	50	40	32	—	16.4	9.0	3.0	5.5	—	2

1/1

119

## SPARE PARTS

Tool holder number	*1					
	Shim	Shim screw	Wedge	Clamp screw	Wrench	Wrench
LSE445 -063A05R/L-E				LS10T		
LSE445 -080A04R/L-E						
LSE445-100A07R/L-E	STBE445NF	CS300890T	CWSE445TR	LS15T	TKY25T	TKY08F
LSE445-125B09R/L-E						
LSE445 -160B11R/L-E						

\*1 Clamp Torque (N • m) : LS10T= 8.5. LS15T= 8.5. CS300890T= 1.0

# LSE445 – INSERTS

P	Steel	●	●		●	●	●	●	●						Cutting conditions: ●: Stable cutting ●: General cutting ✖: Unstable cutting
M	Stainless steel	●	●		●	●	●	●	●						
K	Cast iron				●	✖	●	●	✖	●					Honing: ●: Round F: Sharp S: Chamfer + Hone T: Chamfer Z: Strong
N	Non-ferrous metal														

Order number	Class	Honing	F7010	F7030	MC5020	VP15TF	NX2525	NX4545	UT120T	HTi10	IC	S	BS	RE	Shape
SEEN1203AFFN1	E	F								●	12.7	3.18	1.4	1.0	
SEEN1203AFEN1	E	E				●					12.7	3.18	1.4	1.0	
SEEN1203AFTN1	E	T	●				●		●		12.7	3.18	1.4	1.0	
SEEN1203AFTN3	E	T	●					●	★		12.7	3.18	1.4	—	
SEEN1203AFSN1	E	S		●	●						12.7	3.18	1.4	1.0	
SEEN1203AFSN3	E	S		●							12.7	3.18	1.4	—	
SEEN1203AFZN1	E	Z					●				12.7	3.18	1.4	1.0	
SEEN1203AFEN1	E	E									12.7	3.18	1.4	1.0	

## Inserts with breaker

Order number	Class	Honing	F7010	F7030	MC5020	VP15TF	NX2525	NX4545	UT120T	HTi10	IC	S	BS	RE	Shape
SEER1203AFEN-JS	E	E	●	●	●	●					12.7	3.18	1.4	1.0	
SEER1204AFEN-JS	E	E	●								12.7	3.18	1.4	1.0	

## Wiper inserts

Order number	Class	Honing	F7010	F7030	MC5020	VP15TF	NX2525	NX4545	UT120T	HTi10	IC	S	BS	RE	Shape
WEC42AFTR5C	C	T					●				—	3.18	5	1.0	

1/1

# LSE445

## RECOMMENDED CUTTING CONDITIONS

Material	Hardness	Grade	Vc	fz
P Mild steel	<180HB	F7030	300 (200 – 360)	0.2 (0.1 – 0.3)
		NX4545		
		UTi20T	240 (170 – 300)	
		UP20M		
P Carbon steel Alloy steel	180 – 280HB	F7030	250 (170 – 300)	0.2 (0.1 – 0.3)
		NX4545		
		UTi20T	200 (140 – 240)	
		UP20M		
P Alloy steel	280 – 350HB	UTi20T	140 (100 – 170)	0.15 (0.1 – 0.2)
		M Stainless steel	<200HB	UP20M
UTi20T				
K Cast iron	Tensile Strength <450MPa	MC5020	200 (130 – 240)	0.2 (0.1 – 0.3)
		F5010		
		F5020	160 (110 – 190)	
		UTi20T		
N Aluminium alloy	—	MD220	1000 (200 – 1500)	0.15 (0.05 – 0.25)
		HTi10	1000 (700 – 1200)	0.12 (0.05 – 0.2)

1/1

1. Revolution ( $\text{min}^{-1}$ ) = (1000 x Cutting speed)÷(3.14 x ØD1).
2. Table feed (mm/min) = Feed per tooth×Number of teeth x Cutter revolution.





---

# RRD

---

ROUND INSERT TYPE CUTTERS

VERSATILE PERFORMANCE AND LONG TOOL LIFE

---



*Mplus...*

# RRD

## PRODUCT FEATURES



- Round insert type cutter for mould & die machining
- Versatile range of insert grades for machining up to 60 HRC
- Large range of cutters available, arbor, screw-in, shank and Weldon types
- Wide range of insert sizes, R2.5, 3.5, 5.0, 6.0 and 8.0

# RRD

## ROUND INSERT TYPE CUTTERS

### RRD CUTTERS



### FEATURES

Inserts are available in 3 different tolerances to suit all applications.

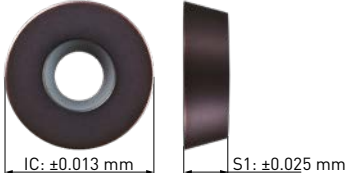
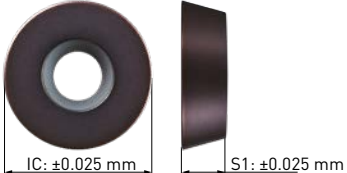
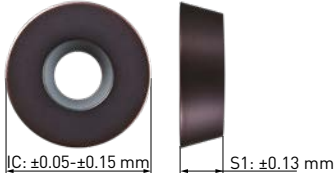
RDHX	RDZX	RDMX
<ul style="list-style-type: none"> <li>• Ground (H Tolerance)</li> <li>• For high precision</li> <li>• For semi-finishing and finishing</li> </ul>	<ul style="list-style-type: none"> <li>• Precision sintered (E Tolerance)</li> <li>• For universal use</li> <li>• Economical insert with long tool life</li> </ul>	<ul style="list-style-type: none"> <li>• Sintered (M Tolerance)</li> <li>• For universal use</li> <li>• For roughing and semi-finishing</li> </ul>
		

## GRADE OVERVIEW

	P	Coated carbide					Uncoated carbide	K	Coated carbide		Uncoated carbide	H	Coated carbide		
↑ Wear resistance	P01	VP05HT	VP10H	VP15TF	VP20M	F7030	UT120T	K01	VP15TF	UT120T	H01	VP05HT	VP10H	VP15TF	
↓ Toughness	P20							K10			H10				
	P30							K20			H20				
	P40							K30			H30				

# RRD N



**P** **K** **H**

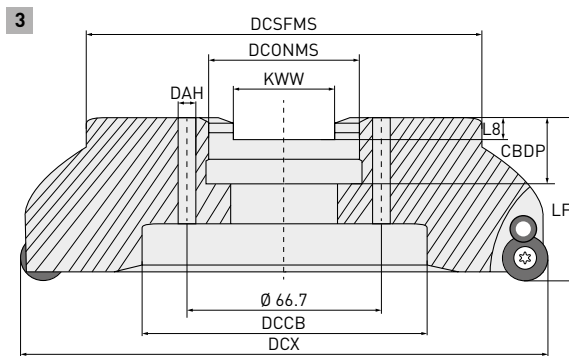
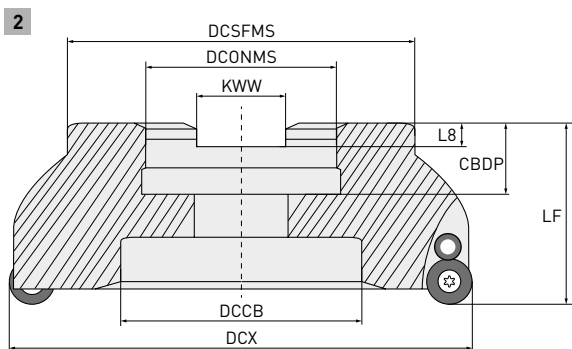
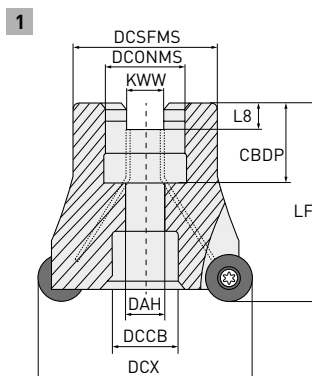

Right hand tool holder only.





## ARBOR TYPE (Neutral)

Order number	Stock	APMX	DCX	DC	LF	DCONMS	CBDP	DAH	DCSFMS	KWW	L8	DCCB	ZEFP		
RRD050N-042A06R	●	5	42	32	44	16	18	9	33	8.4	5.7	15	6	●	1
RRD050N-052A07R	●	5	52	42	50	22	20	11	44	10.4	6.3	18	7	●	1
RRD060N-042A05R	●	6	42	30	42	16	18	9	33	8.4	5.7	15	5	●	1
RRD060N-050A05R	●	6	50	38	50	22	20	11	44	10.4	6.3	18	5	●	1
RRD060N-052A05R	●	6	52	40	50	22	20	11	44	10.4	6.3	18	5	●	1
RRD060N-063A06R	●	6	63	51	50	22	20	11	44	10.4	6.3	18	6	●	1
RRD080N-050A04R	●	8	50	34	50	22	20	11	44	10.4	6.3	18	4	●	1
RRD080N-052A04R	●	8	52	36	50	22	20	11	4	10.4	6.3	18	4	●	1
RRD080N-052A05R	●	8	52	36	50	22	20	11	4	10.4	6.3	18	5	●	1
RRD080N-063A05R	●	8	63	47	50	22	20	11	4	10.4	6.3	18	5	●	1
RRD080N-066A05R	●	8	66	50	50	27	22	13.5	53	12.4	7.2	20	5	●	1
RRD080N-080A06R	●	8	80	64	52	27	22	13.5	64	12.4	7.2	20	6	●	1
RRD080N-100A07R	●	8	100	84	52	32	29	—	72	14.4	8	46	7	—	2
RRD080N-125B08R	●	8	125	109	52	40	30	—	82	16.4	9	58	8	—	2
RRD080N-160C09R	□	8	160	144	52	40	29	14	90	16.4	9	92	9	—	3

1/1

# RRD N

## SPARE PARTS

Order number	RE						
		Shim	Shim screw	Clamp screw	Insert clamp screw	Wrench	
RRD050N-	042A06R				—		
	052A07R						
RRD060N-	042A05R	—	—	B-TS35		TKY15F	
	050A05R				TS1001		
	052A05R						
	063A06R						
RRD080N-	050A04R						
	052A04R						
	052A05R						
	063A05R						
	066A05R	8	KS-12	B-TS45	214	—	TKY20F
	080A06R						
	100A07R						
125B08R							
160C09R							

# RRD P

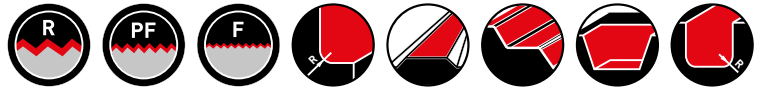

**P** **K** **H**

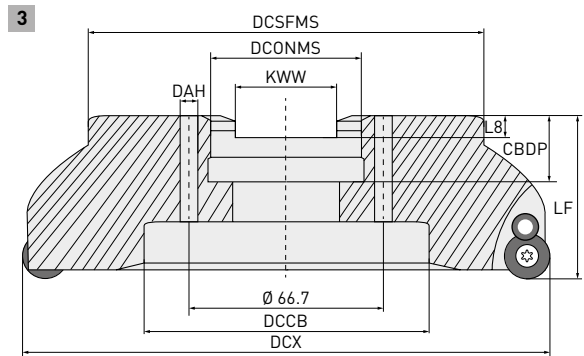
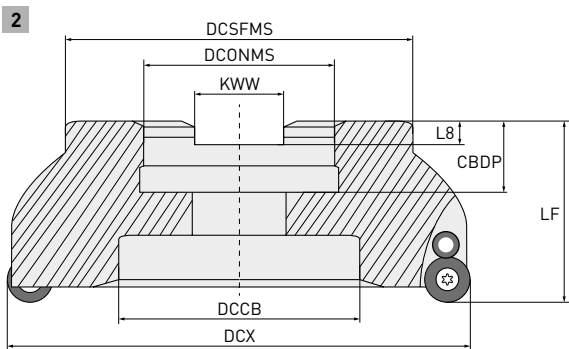
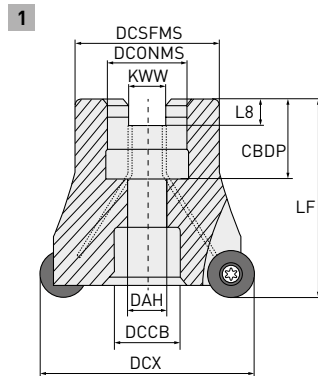

Right hand tool holder only.





## ARBOR TYPE (Positive)

Order number	Stock	APMX	DCX	DC	LF	DCONMS	CBDP	DAH	DCSFMS	KWW	L8	DCCB	ZFP	Typ	
RRD060P-050A05R	●	6	50	38	50	22	20	11	44	10.4	6.3	18	5	1	RDH/M/Z 12T3M0E
RRD060P-052A05R	●	6	52	40	50	22	20	11	44	10.4	6.3	18	5	1	
RRD060P-063A06R	●	6	63	51	50	22	20	11	44	10.4	6.3	18	6	1	
RRD060P-066A06R	●	6	66	54	52	27	22	13.5	53	12.4	7.2	20	6	1	
RRD060P-080A07R	●	6	80	68	50	27	22	13.5	64	12.4	7.2	20	7	1	
RRD080P-050A04R	●	8	50	34	50	22	20	11	44	10.4	6.3	18	4	1	RDH/M/Z 1604M0E
RRD080P-063A05R	●	8	63	47	50	22	20	11	44	10.4	6.3	18	5	1	
RRD080P-066A05R	●	8	66	50	50	27	22	13.5	53	12.4	7.2	20	5	1	
RRD080P-080A06R	●	8	80	64	52	27	22	13.5	64	12.4	7.2	20	6	1	
RRD080P-100A07R	●	8	100	84	52	32	29	—	72	14.4	8	46	7	2	
RRD080P-125B08R	●	8	125	109	52	40	30	—	82	16.4	9	58	8	2	
RRD080P-160C09R	●	8	160	144	52	40	29	14	90	16.4	9	92	9	3	

1/1

# RRD P

## SPARE PARTS

Order number	RE						
		Shim	Shim screw	Clamp screw	Insert clamp screw	Wrench	
RRD060P-	050A05R						
	052A05R						
	063A06R	6	—	—	B-TS35	TS1001	TKY15F
	066A06R						
	080A07R						
RRD080P-	050A04R						
	063A05R						
	066A05R						
	080A06R	8	KS-12	B-TS45	214	—	TKY20F
	100A07R						
	125B08R						
160C09R							

# RRD

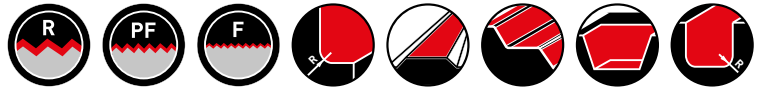

P K H

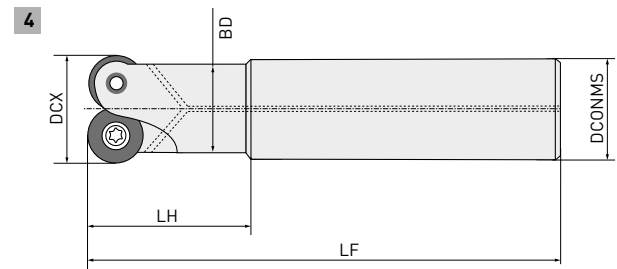
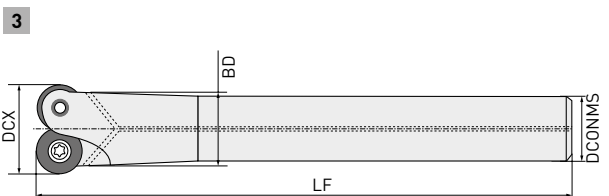
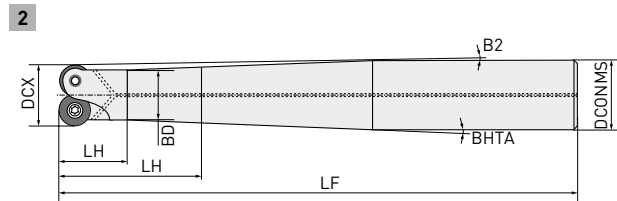
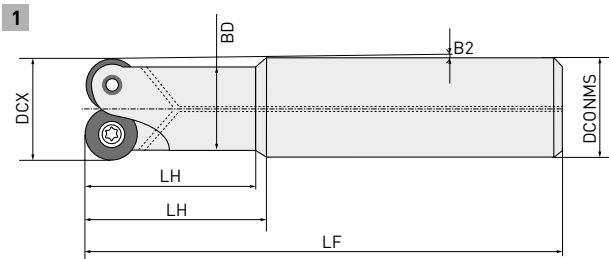
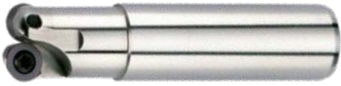

Right hand tool holder only.

## STRAIGHT SHANK TYPE





Order number	Stock	APMX	DCX	DCONMS	LF	LU	LH	BD	B2	BHTA	ZEFP		Typ	
RRD025R102S10Z	●	2.5	10	10	75	—	23	—	—	0.89	2	●	4	RDH/Z 0501M0
RRD025R123S12Z	●	2.5	12	12	75	—	23	11	—	—	3	●	4	
RRD025R154S16Z	●	2.5	15	16	80	22	22.5	14	1.4	45	4	●	1	
RRD035R122S10Z	●	3.5	12	10	75	23	—	11	—	—	2	●	3	RDH/M/Z 07T1M0
RRD035R122S12Z	●	3.5	12	12	75	—	23	11	—	—	2	●	4	
RRD035R122S16Z	□	3.5	12	16	88	15	18.4	11	4	8.37	2	●	2	
RRD035R122S16ZL	●	3.5	12	16	128	15	22.4	11	2.36	3.87	2	●	2	
RRD035R122S16ZM	●	3.5	12	16	109	15	22.4	11	2.36	3.87	2	●	2	
RRD035R152S16Z	□	3.5	15	16	88	18	27.6	14	1	6.52	2	●	2	
RRD035R152S16ZM	●	3.5	15	16	108	18	41.4	14	0.59	2.69	2	●	2	RDH/M/Z 0702M0
RRD035R152S20Z	●	3.5	15	20	130	20	35.6	14	2.12	4.04	2	●	2	
RRD035R152S20ZM	●	3.5	15	20	150	20	41.7	14	1.64	2.9	2	●	2	
RRD035R152S25Z	□	3.5	15	25	176	20	36.8	14	2.64	3.8	2	●	2	RDH/M/Z 07T1M0
RRD035R153S12Z	□	3.5	15	12	75	17	—	12.8	—	—	3	●	3	
RRD035R153S16Z	□	3.5	15	16	78	29.5	30	14	1.08	45	3	●	1	
RRD050R202S20Z	●	5	20	20	90	—	31	18	—	—	2	●	4	RDH/M/Z 1003M0
RRD050R202S20ZM	●	5	20	20	110	—	51	18	—	—	2	●	4	
RRD050R202S25Z	●	5	20	25	136	68.5	69.5	18	2.13	45	2	●	1	
RRD050R202S25ZL	●	5	20	25	176	108.5	109.5	18	1.34	45	2	●	1	
RRD050R202S25ZM	●	5	20	25	156	88.5	89.5	18	1.64	45	2	●	1	

1/1



# RRD

## SPARE PARTS

Order number	RE						
		Shim	Shim screw	Clamp screw	Insert clamp screw	Wrench	
RRD025R-	102S10Z						
	123S12Z	2.5	—	—	B-TS20	—	TKY06F
	54S16Z						
RRD035R-	122S10Z						
	122S12Z						
	122S16Z		—	—	B-TS253	—	TKY07F
	122S16ZL						
	122S16ZM						
	152S16Z	3.5					
	152S16ZM						
	152S20Z		—	—	TS25	—	TKY08F
	152S20ZM						
	152S25Z						
153S12Z		—	—	TS253	—	TKY08F	
153S16Z							
RRD050R-	202S20Z						
	202S20ZM						
	202S25Z	5	—	—	B-TS35	—	TKY15F
	202S25ZL						
	202S25ZM						

# RRD

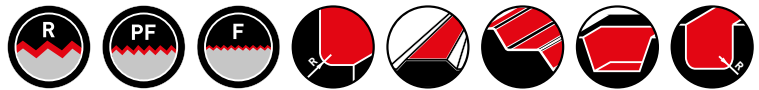

P

K

H

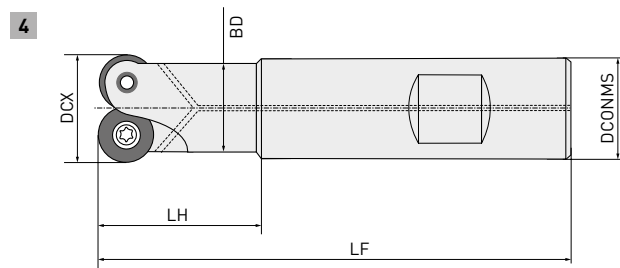
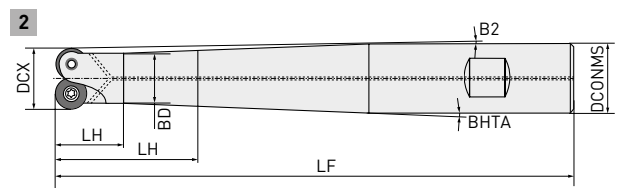
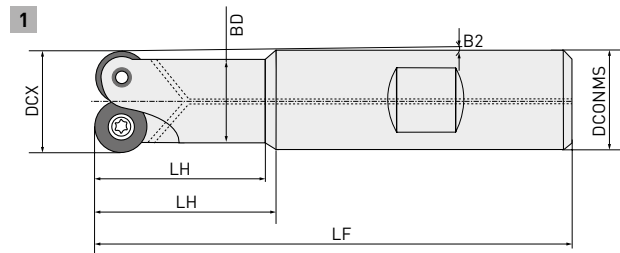
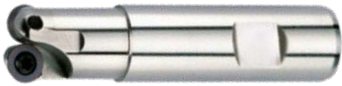

Right hand tool holder only.





## WELDON SHANK TYPE

Order number	Stock	APMX	DCX	DCONMS	LF	LU	LH	BD	B2	BHTA	ZEFP		Typ	
RRD035R122S16W	●	3.5	12	16	88	15	18.4	11	4	8.37	2		2	RDH/M/Z 07T1M0
RRD035R122S16WL	●	3.5	12	16	128	15	22.4	11	2.36	3.87	2		2	
RRD035R122S16WM	□	3.5	12	16	108	15	22.4	11	2	3.87	2		2	
RRD035R152S16W	□	3.5	15	16	88	18	27.6	12.8	1	6.52	2		2	RDH/M/Z 0702M0
RRD035R152S16WM	□	3.5	15	16	108	18	41.38	12.8	0.59	2.69	2		2	
RRD035R152S20W	□	3.5	15	20	130	20	35.58	12.8	2.12	4.04	2		2	
RRD035R152S20WM	□	3.5	15	20	150	20	41.7	12.8	1.64	2.9	2		2	RDH/M/Z 07T1M0
RRD035R152S25W	□	3.5	15	25	176	20	36.8	12.8	3.8	2.65	2		2	
RRD035R153S16W	□	3.5	15	16	78	28.4	29.5	12.8	1.08	45	3		1	
RRD050R202S20W	●	5	20	20	90	—	31	18	—	—	2		4	RDH/M/Z 1003M0
RRD050R202S20WM	●	5	20	20	110	—	51	18	—	—	2		4	
RRD050R202S25W	●	5	20	25	136	23	37	18	2.13	4.09	2		2	
RRD050R202S25WL	□	5	20	25	176	47.6	23	18	1.34	2.25	2		2	
RRD050R202S25WM	□	5	20	25	156	42.7	23	18	1.64	2.9	2		2	

1/1

# RRD

## SPARE PARTS

Order number	RE					
		Shim	Shim screw	Clamp screw	Insert clamp screw	Wrench
	122S16W					
	122S16WL	—	—	B-TS253	—	TKY07F
	122S16WM					
	152S16W					
RRD035R-	152S16WM	3.5				
	152S20W			TS25		TKY08F
	152S20WM	—	—		—	
	152S25W					
	153S16W			TS253		
	202S20W					
	202S20WM					
RRD050R-	202S25W	5	—	B-TS35	—	TKY15F
	202S25WL					
	202S25WM					

# RRD

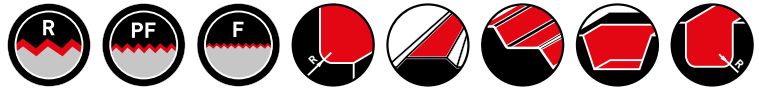

P K H

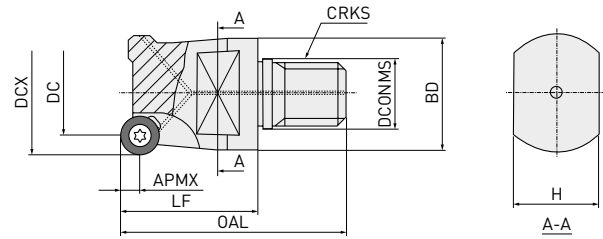

Right hand tool holder only.

## SCREW-IN TYPE





Order number	Stock	APMX	DCX	DC	OAL	LF	DCONMS	DCSFMS	CRKS	H	ZEFP		
RRD025R102M5	□	2.5	10	5	35	20	5.5	9.9	M5	6	2		
RRD025R123M8	●	2.5	12	7	38	20	8.5	13.5	M8	9	3		RDH/Z
RRD025R154M8	●	2.5	15	10	38	20	8.5	13.5	M8	10	4		0501M0
RRD025R205M10	●	2.5	20	15	44	25	10.5	18	M10	15	5		
RRD035R122M8	●	3.5	12	5	46	28	8.5	13.5	M8	9	2		
RRD035R153M8	●	3.5	15	8	46	28	8.5	13.5	M8	10	3		
RRD035R204M10	●	3.5	20	13	47	28	10.5	18	M10	15	4		RDH/M/Z
RRD035R255M12	●	3.5	25	18	50	28	12.5	21	M12	17	5		07T1M0
RRD035R306M16	●	3.5	30	23	51	28	17	29	M16	22	6		
RRD035R357M16	●	3.5	35	28	51	28	17	29	M16	22	7		
RRD035R152M8	●	3.5	15	8	46	28	8.5	13.5	M8	10	2		RDH/M/Z
RRD035R153M8X	●	3.5	15	8	43	28	8.5	13.5	M8	10	3		0702M0
RRD050R202M10	●	5	20	10	47	28	10.5	18	M10	15	2		
RRD050R252M12	●	5	25	15	54	32	12.5	21	M12	17	2		
RRD050R253M12	●	5	25	15	54	32	12.5	21	M12	17	3		
RRD050R304M12	●	5	30	20	54	32	12.5	21	M12	17	4		RDH/M/Z
RRD050R304M16	●	5	30	20	55	32	17	29	M16	22	4		1003M0
RRD050R355M16	●	5	35	25	65	42	17	29	M16	22	5		
RRD050R426M16	●	5	42	32	65	42	17	29	M16	22	6		
RRD060R242M12	●	6	24	12	54	32	12.5	21	M12	17	2		
RRD060R353M16	●	6	35	23	65	42	17	29	M16	22	3		
RRD060R354M16	●	6	35	23	65	42	17	29	M16	22	4		RDH/M/Z
RRD060R424M16	●	6	42	30	55	32	17	29	M16	24	4		12T3M0
RRD060R425M16	●	6	42	30	65	42	17	29	M16	22	5		
RRD080R322M16	●	8	32	16	65	42	17	29	M16	22	2		RDH/M/Z 1604M0

1/1

134

# RRD

## SPARE PARTS

Order number	RE							
		Shim	Shim screw	Clamp screw	Insert clamp screw	Wrench		
RRD025R-	102M5							
	123M8	2.5	—	—	B-TS20	—	TKY06F	
	154M8							
	205M10							
122M8	3.5							—
153M8								
204M10								
255M12		TKY08F						
306M16								
357M16								
152M8	TKY08F							
153M8X		TS25	—					
RRD050R-	202M10	5	—	—	B-TS35	—	TKY15F	
	252M12							
	253M12							
	304M12							
	304M16							
	355M16							
426M16								
RRD060R-	242M12	6	—	—	B-TS35	—	TKY15F	
	353M16							
	354M16							TS1001
	424M16							
425M16								
RRD080R-	322M16	8	—	—	214	—	TKY20F	

# INSERTS

P	Steel	●	●	●	●	●	●
K	Cast iron		✘	✘	●	●	✘
H	Hardened materials		●		●	●	

Cutting conditions:

●: Stable cutting ●: General cutting ✘: Unstable cutting

Order number	Class	Honing	F7030	VP15TF	VP20M	VP10H	VP05HT	UTi20T	IC	S
RDHX0501M0E	H	E	●	●		●	●		5	1.5
RDHX0501M0S	H	S	●	●		●			5	1.5
RDHX07T1M0E	H	E	●	●		●	●		7	1.98
RDHX07T1M0S	H	S	●	●		●	●		7	1.98
RDHX0702M0E	H	E	●	●		●	●		7	2.38
RDHX0702M0S	H	S	●	●		●			7	2.38
RDHX1003M0E	H	E	●	●		●	●		10	3.18
RDHX1003M0S	H	S	●	●		●	●		10	3.18
RDHX12T3M0E	H	E	●	●		●	●		12	3.97
RDHX12T3M0S	H	S	●	●		●			12	3.97
RDHX1604M0E	H	E	●	●		●	●		16	4.76
RDHX1604M0S	H	S	●	●		●			16	4.76
RDMX07T1M0E	M	E					●		7	1.98
RDMX07T1M0T	M	T	●	●	●				7	1.98
RDMX0702M0E	M	E					●		7	2.38
RDMX0702M0T	M	T	●	●	●			□	7	2.38
RDMX1003M0E	M	E					●		10	3.18
RDMX1003M0S	M	S		●	●				10	3.18
RDMX1003M0T	M	T	●	●	●		●		10	3.18
RDMX12T3M0E	M	E					●		12	3.97
RDMX12T3M0S	M	S		●	●				12	3.97
RDMX12T3M0T	M	T	●	●	●		●		12	3.97
RDMX1604M0E	M	E					●		16	4.76
RDMX1604M0S	M	S		●	●				16	4.76
RDMX1604M0T	M	T	●	●	●		●		16	4.76
RDZX0501M0E	Z	E		●					5	1.50
RDZX07T1M0E	Z	E		●					7	1.98
RDZX0702M0E	Z	E		●					7	2.38
RDZX1003M0E	Z	E		●					10	3.18
RDZX1003M0S	Z	S	●	●					10	3.18
RDZX12T3M0E	Z	E		●					12	3.97
RDZX12T3M0S	Z	S	●	●					12	3.97
RDZX1604M0E	Z	E		●					16	4.76
RDZX1604M0S	Z	S	●	●					16	4.76

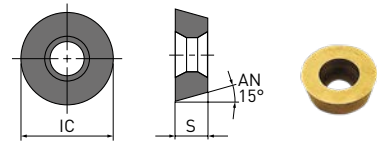

IC: ±0.013 mm S: ±0.025 mm

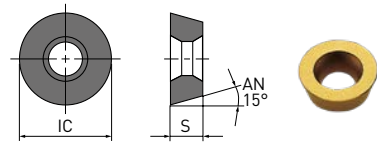

IC: ±0.05-±0.15 mm S: ±0.15 mm

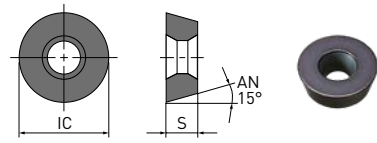

IC: ±0.025 mm S: ±0.025 mm

1/1

## CUTTING EDGE PREPARATION

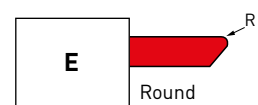
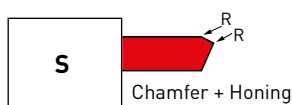

For roughing

For roughing and finishing

For finishing

●: Inventory maintained. □: Produced to order only.

# RRD

## RECOMMENDED CUTTING CONDITIONS

### CUTTING CONDITIONS FOR ROUGHING (ae = 50 % of Ø)

Material	Hardness	Grade	Vc	Ø 10 – 15 mm		Ø 20 mm		Ø 24 – 25 mm		Ø 30 – 42 mm		Ø 50 – 80 mm		Ø 100 – 160 mm	
				ap	fz	ap	fz	ap	fz	ap	fz	ap	fz	ap	fz
P Mild steel	<180HB	F7030 VP15TF	(250 – 320)	-0.2	0.25	-0.5	0.45	-1.0	0.35	-1.0	0.40	-1.0	0.50	-1.5	0.60
			(240 – 300)	0.2–0.3	0.20	0.5–1.0	0.25	1.0–2.0	0.30	1.5–2.0	0.32	1.0–1.5	0.40	1.5–2.5	0.45
			(200 – 280)	0.3–0.5	0.12	1.0–1.5	0.15	2.0–2.5	0.20	2.0–3.0	0.25	1.5–3.0	0.35	2.5–5.0	0.35
Carbon steel Alloy steel	180 – 350HB	F7030 VP15TF	(220 – 300)	-0.2	0.20	-0.5	0.40	-1.0	0.30	-1.0	0.40	-1.0	0.50	-1.5	0.55
			(200 – 290)	0.2–0.3	0.15	0.5–1.0	0.20	1.0–1.5	0.25	1.5–2.0	0.30	1.0–1.5	0.38	1.5–2.5	0.40
			(160 – 250)	0.3–0.5	0.10	1.0–1.5	0.10	1.5–2.0	0.22	2.0–3.0	0.22	1.5–3.0	0.30	2.5–4.5	0.32
K Cast iron	Tensile Strength <450MPa	VP15TF VP20M VP10H	(200 – 250)	-0.1	0.15	-0.5	0.18	-1.0	0.20	-1.0	0.25	-1.0	0.30	-1.5	0.35
			(180 – 230)	0.1–0.2	0.10	0.5–1.0	0.10	1.0–1.5	0.15	1.5–2.0	0.18	1.0–1.5	0.25	1.5–2.5	0.22
			(160 – 200)	0.2–0.25	0.10	1.0–1.5	0.10	1.5–2.0	0.12	2.0–3.0	0.15	1.5–3.0	0.18	2.5–4.5	0.20
H Hardened steel	-52HRC -58HRC -60HRC	VP15TF VP10H VP05HT	(140 – 200)	-0.1	0.12	-0.1	0.14	-0.1	0.15	-0.1	0.18	-0.1	0.18	-0.1	0.20
			(110 – 180)	0.1–0.15	0.10	0.1–0.20	0.12	0.1–0.30	0.12	0.1–0.30	0.14	0.1–0.30	0.14	0.1–0.30	0.15
			(100 – 170)	0.1–0.15	0.10	0.1–0.20	0.10	0.1–0.30	0.10	0.1–0.30	0.12	0.1–0.30	0.12	0.1–0.30	0.12

1/1

1. When using a full width of cut please reduce the cutting conditions by 20 %.
2. When using a long overhang please reduce the feed rate by 20 %.

### CUTTING CONDITIONS FOR FINISHING (ae = 20 % of Ø)

Material	Hardness	Grade	Vc	Ø 10 – 15 mm		Ø 20 mm		Ø 24 – 25 mm		Ø 30 – 42 mm		Ø 50 – 80 mm		Ø 100 – 160 mm	
				ap	fz	ap	fz	ap	fz	ap	fz	ap	fz	ap	fz
P Mild steel	<180HB	F7030 VP15TF	(260 – 360)	-0.1	0.15	-0.15	0.20	-0.15	0.25	-0.15	0.30	-0.15	0.32	-0.3	0.35
			(240 – 320)	0.1–0.2	0.15	0.1–0.2	0.15	0.1–0.2	0.18	0.1–0.3	0.20	0.1–0.3	0.22	0.2–0.3	0.25
			(220 – 280)	0.2–0.24	0.10	0.1–0.30	0.15	0.1–0.30	0.18	0.1–0.30	0.20	0.2–0.30	0.20	0.3–0.40	0.20
Carbon steel Alloy steel	180 – 350HB	F7030 VP15TF	(250 – 350)	-0.1	0.12	-0.1	0.15	-0.1	0.18	-0.1	0.25	-0.1	0.28	-0.15	0.30
			(230 – 310)	0.1–0.15	0.12	0.1–0.30	0.15	0.1–0.30	0.15	0.1–0.30	0.20	0.1–0.3	0.22	0.15–0.3	0.25
			(210 – 270)	0.15–0.2	0.10	0.15–0.30	0.12	0.15–0.30	0.15	0.15–0.30	0.15	0.2–0.3	0.18	0.2–0.3	0.18
K Cast iron	Tensile Strength <450MPa	VP15TF VP20M VP10H	(200 – 300)	-0.1	0.15	-0.1	0.18	-0.1	0.20	-0.1	0.22	-0.1	0.25	-0.15	0.30
			(200 – 280)	0.1–0.2	0.10	0.1–0.30	0.10	0.1–0.3	0.15	0.1–0.3	0.15	0.1–0.3	0.20	0.15–0.3	0.22
			(180 – 240)	0.2–0.25	0.10	0.2–0.40	0.10	0.2–0.4	0.12	0.2–0.4	0.12	0.2–0.4	0.15	0.2–0.4	0.18
H Hardened steel	-52HRC -58HRC -60HRC	VP15TF VP10H VP05HT	(150 – 200)	-0.1	0.15	-0.1	0.14	-0.1	0.15	-0.1	0.18	-0.1	0.18	-0.1	0.20
			(120 – 180)	0.1–0.15	0.10	0.1–0.20	0.12	0.1–0.30	0.12	0.1–0.30	0.14	0.1–0.30	0.14	0.1–0.30	0.15
			(100 – 180)	0.1–0.15	0.10	0.1–0.20	0.10	0.1–0.30	0.10	0.1–0.30	0.12	0.1–0.30	0.12	0.1–0.30	0.12

1/1

1. When using a full width of cut please reduce the cutting conditions by 20 %.
2. When using a long overhang please reduce the feed rate by 20 %.

---

# TAFS, TAFM, TAFL

---

INDEXABLE INSERT DRILL

LOW DRILLING NOISE AND TOUGH BODY

---



*M*plus...



# TAFS, TAFM, TAFL

## INDEXABLE INSERT DRILL

### FEATURES

#### Tough body

- The wide web design reduces chattering.
- Lower cutting noise.
- High insert seat rigidity for reliable insert location.

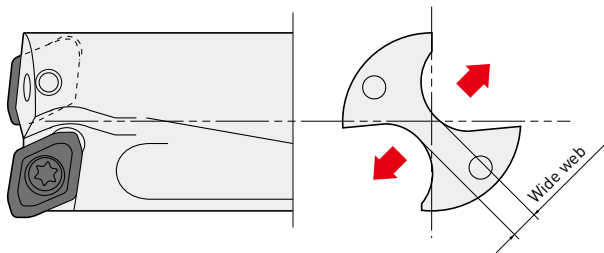

#### Economical insert

- Economical four corner use.

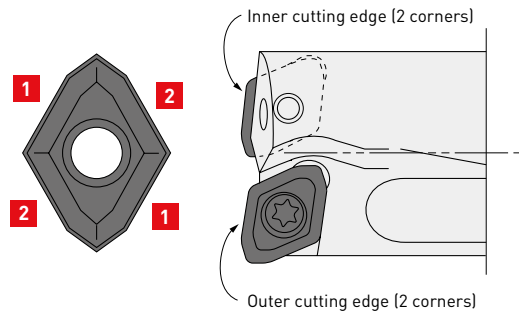

**1** Inner edge

**2** Outer edge



# TAFS, TAFM, TAFL

## CUTTING PERFORMANCE

### CHIP GEOMETRY

#### U1 Breaker

Material	Mild steel
Drill diameter (mm)	Ø 25
Vc (m/min)	200
f (mm/rev)	0.10



#### U2 Breaker

Material	DIN X5CrNi189
Drill diameter (mm)	Ø 25
Vc (m/min)	150
f (mm/rev)	0.10



#### U3 Breaker

Material	DIN Ck45
Drill diameter (mm)	Ø 25
Vc (m/min)	150
f (mm/rev)	0.14



#### U3 Breaker

Material	DIN 42CrMo4
Drill diameter (mm)	Ø 25
Vc (m/min)	150
f (mm/rev)	0.12



## CUTTING RESISTANCE

### POWER CONSUMPTION

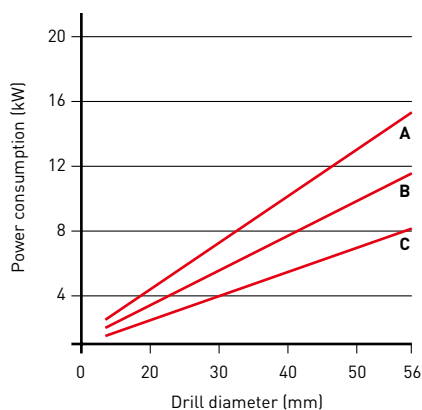

### TORQUE

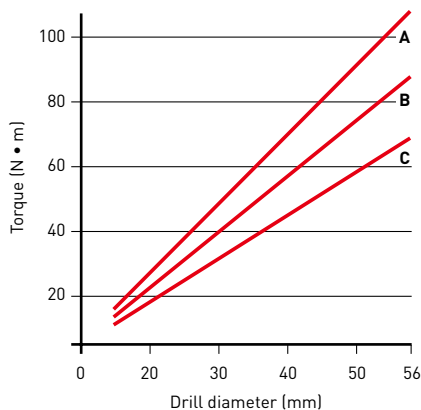

### THRUST

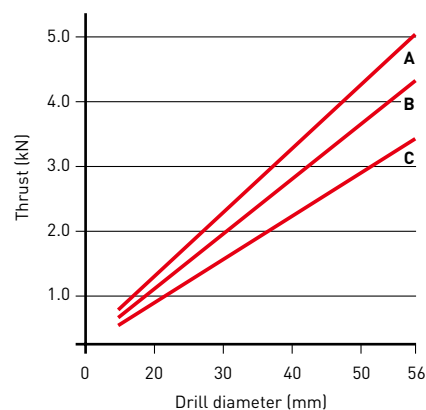

1. Workpiece: DIN X5CrNi189 (220HB) Cutting speed: 150 m/min Insert: U2 Breaker

A: f = 0.15 mm/rev B: f = 0.1 mm/rev C: f = 0.06 mm/rev

# TAFS, TAFM, TAFL

## CUTTING NOISE

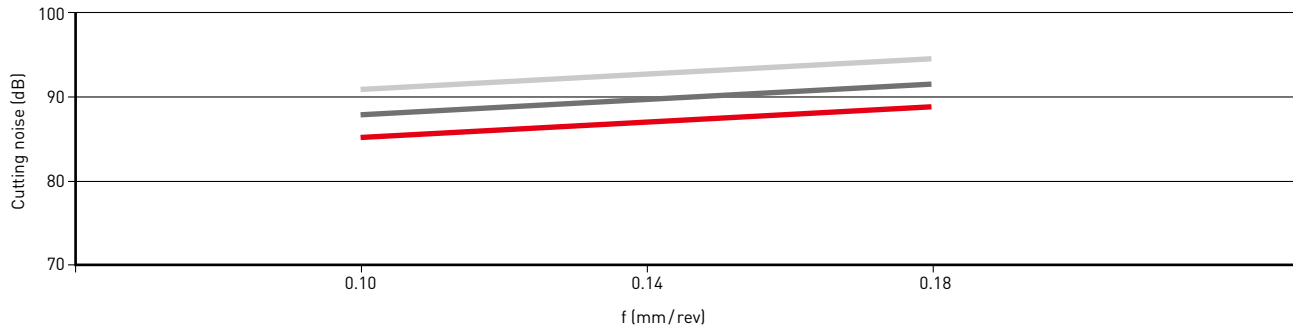

1. Workpiece: DIN 42CrMo4 (200 – 220 HB) Drill diameter (mm):  $\varnothing$  25 Cutting speed: 150 m/min Insert: U2 Breaker

## CUTTING RESISTANCE

### POWER CONSUMPTION

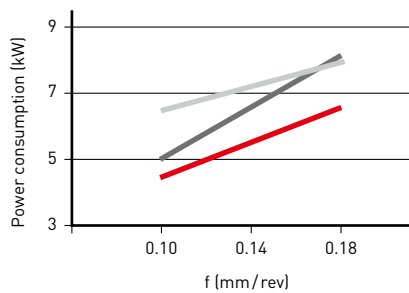

### TORQUE

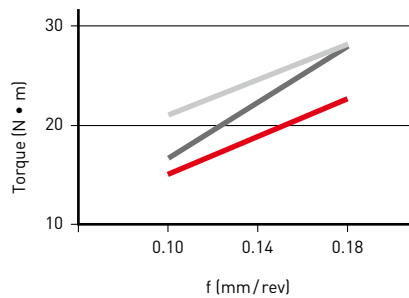

### THRUST

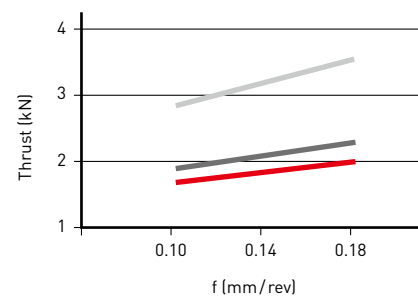

1. Workpiece: DIN 42CrMo4 (200 – 220 HB) Drill diameter (mm):  $\varnothing$  25 Cutting speed: 150 m/min Insert: U3 Breaker

## IDENTIFICATION

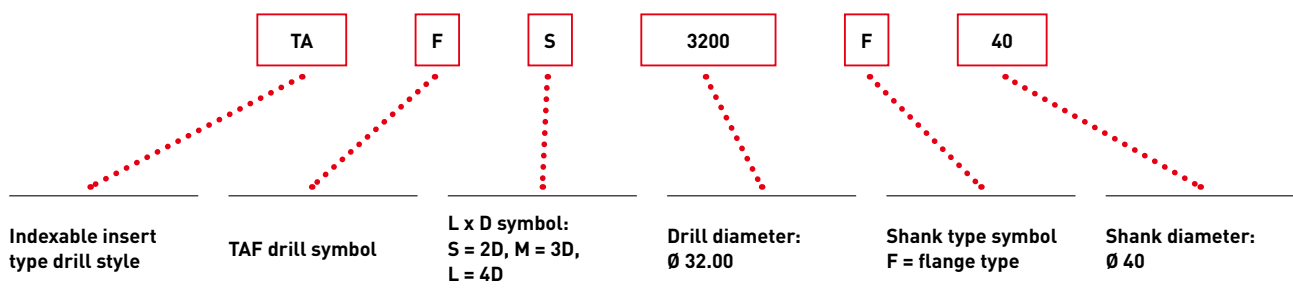

# TAFS, TAFM, TAFL

P M K

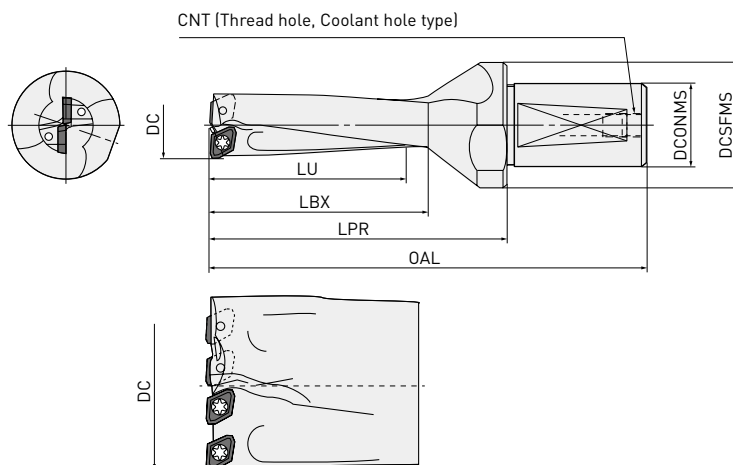

Number of teeth = 4 (DC > 49)

Order number	Stock	DC	L/D	ZNF	LU	LBX	LPR	OAL	DCONMS	DCSFMS	CNT	Insert
TAFS1200F20	●		2		24	29	39	82	20	25	PT1/8	
TAFM1200F20	●	12.0	3	2	36	41	51	94	20	25	PT1/8	GCMT040204-U <sup>○</sup>
TAFL1200F20	●		4		48	53	63	106	20	25	PT1/8	
TAFS1250F20	●		2		25	29	39	82	20	25	PT1/8	
TAFM1250F20	●	12.5	3	2	37.5	41	51	94	20	25	PT1/8	GCMT040204-U <sup>○</sup>
TAFL1250F20	●		4		50	53	63	106	20	25	PT1/8	
TAFS1300F20	●		2		26	31	41	84	20	25	PT1/8	
TAFM1300F20	●	13.0	3	2	39	44	54	97	20	25	PT1/8	GCMT040204-U <sup>○</sup>
TAFL1300F20	●		4		52	57	67	110	20	25	PT1/8	
TAFS1350F20	●		2		27	31	41	84	20	25	PT1/8	
TAFM1350F20	●	13.5	3	2	40.5	44	54	97	20	25	PT1/8	GCMT040204-U <sup>○</sup>
TAFL1350F20	●		4		54	57	67	110	20	25	PT1/8	
TAFS1400F20	●		2		28	33	43	86	20	25	PT1/8	
TAFM1400F20	●	14.0	3	2	42	47	57	100	20	25	PT1/8	GCMT040204-U <sup>○</sup>
TAFL1400F20	●		4		56	61	71	114	20	25	PT1/8	
TAFS1450F20	●		2		29	33	43	86	20	25	PT1/8	
TAFM1450F20	●	14.5	3	2	43.5	47	57	100	20	25	PT1/8	GCMT040204-U <sup>○</sup>
TAFL1450F20	●		4		58	61	71	114	20	25	PT1/8	
TAFS1500F20	●		2		30	35	45	88	20	25	PT1/8	
TAFM1500F20	●	15.0	3	2	45	50	60	103	20	25	PT1/8	GPMT060204-U <sup>○</sup>
TAFL1500F20	●		4		60	65	75	118	20	25	PT1/8	
TAFS1550F20	●		2		31	35	45	88	20	25	PT1/8	
TAFM1550F20	●	15.5	3	2	46.5	50	60	103	20	25	PT1/8	GPMT060204-U <sup>○</sup>
TAFL1550F20	●		4		62	65	75	118	20	25	PT1/8	
TAFS1600F25	●		2		32	38	57	107	25	35	PT1/8	
TAFM1600F25	●	16.0	3	2	48	54	73	123	25	35	PT1/8	GPMT060204-U <sup>○</sup>
TAFL1600F25	●		4		64	70	89	139	25	35	PT1/8	
TAFS1650F25	●		2		33	38	57	107	25	35	PT1/8	
TAFM1650F25	●	16.5	3	2	49.5	54	73	123	25	35	PT1/8	GPMT060204-U <sup>○</sup>

1/5

## TAFS, TAFM, TAFL

Order number	Stock	DC	L/D	ZNF	LU	LBX	LPR	OAL	DCONMS	DCSFMX	CNT	Insert
TAFS1700F25	●		2		34	41	59	109	25	35	PT1/8	
TAFM1700F25	●	17.0	3	2	51	58	76	126	25	35	PT1/8	GPMT060204-U○
TAFL1700F25	●		4		68	75	93	143	25	35	PT1/8	
TAFS1750F25	●		2		35	41	59	109	25	35	PT1/8	
TAFM1750F25	●	17.5	3	2	52.5	58	76	126	25	35	PT1/8	GPMT060204-U○
TAFL1750F25	●		4		70	75	93	143	25	35	PT1/8	
TAFS1800F25	●		2		36	43	61	111	25	35	PT1/8	
TAFM1800F25	●	18.0	3	2	54	61	79	129	25	35	PT1/8	GPMT070204-U○
TAFL1800F25	●		4		72	79	97	147	25	35	PT1/8	
TAFS1850F25	●		2		37	43	61	111	25	35	PT1/8	
TAFM1850F25	●	18.5	3	2	55.5	61	79	129	25	35	PT1/8	GPMT070204-U○
TAFS1900F25	●		2		38	46	63	113	25	35	PT1/8	
TAFM1900F25	●	19.0	3	2	57	65	82	132	25	35	PT1/8	GPMT070204-U○
TAFL1900F25	●		4		76	84	101	151	25	35	PT1/8	
TAFS1950F25	●		2		39	46	63	113	25	35	PT1/8	
TAFM1950F25	●	19.5	3	2	58.5	65	82	132	25	35	PT1/8	GPMT070204-U○
TAFS2000F25	●		2		40	48	65	115	25	35	PT1/8	
TAFM2000F25	●	20.0	3	2	60	68	85	135	25	35	PT1/8	GPMT070204-U○
TAFL2000F25	●		4		80	88	105	155	25	35	PT1/8	
TAFS2050F25	●		2		41	48	65	115	25	35	PT1/8	
TAFM2050F25	●	20.5	3	2	61.5	68	85	135	25	35	PT1/8	GPMT070204-U○
TAFS2100F25	●		2		42	50	67	117	25	35	PT1/8	
TAFM2100F25	●	21.0	3	2	63	71	88	138	25	35	PT1/8	GPMT070204-U○
TAFL2100F25	●		4		84	92	109	159	25	35	PT1/8	
TAFS2150F25	●		2		43	50	67	117	25	35	PT1/8	
TAFM2150F25	●	21.5	3	2	64.5	71	88	138	25	35	PT1/8	GPMT070204-U○
TAFS2200F25	●		2		44	53	69	119	25	35	PT1/8	
TAFM2200F25	●	22.0	3	2	66	75	91	141	25	35	PT1/8	GPMT070204-U○
TAFL2200F25	●		4		88	97	113	163	25	35	PT1/8	
TAFS2250F25	●		2		45	53	69	119	25	35	PT1/8	
TAFM2250F25	●	22.5	3	2	67.5	75	91	141	25	35	PT1/8	GPMT070204-U○
TAFS2300F25	●		2		46	55	71	121	25	35	PT1/8	
TAFM2300F25	●	23.0	3	2	69	78	94	144	25	35	PT1/8	GPMT090304-U○
TAFL2300F25	●		4		92	101	117	167	25	35	PT1/8	
TAFS2350F25	●		2		47	55	71	121	25	35	PT1/8	
TAFM2350F25	●	23.5	3	2	70.5	78	94	144	25	35	PT1/8	GPMT090304-U○
TAFL2350F25	●		4		94	101	117	167	25	35	PT1/8	
TAFS2400F25	●		2		48	58	73	123	25	35	PT1/8	
TAFM2400F25	●	24.0	3	2	72	82	97	147	25	35	PT1/8	GPMT090304-U○
TAFL2400F25	●		4		96	106	121	171	25	35	PT1/8	
TAFS2450F25	●		2		49	58	73	123	25	35	PT1/8	
TAFM2450F25	●	24.5	3	2	73.5	82	97	147	25	35	PT1/8	GPMT090304-U○
TAFS2500F32	●		2		50	60	75	130	32	42	PT1/8	
TAFM2500F32	●	25.0	3	2	75	85	100	155	32	42	PT1/8	GPMT090304-U○
TAFL2500F25	●		4		100	110	125	180	25	35	PT1/8	
TAFL2500F32	●		4		100	110	125	180	32	42	PT1/8	
TAFS2550F32	●		2		51	60	75	130	32	42	PT1/8	
TAFM2550F32	●	25.5	3	2	76.5	85	100	155	32	42	PT1/8	GPMT090304-U○
TAFS2600F32	●		2		52	62	77	132	32	42	PT1/8	
TAFM2600F32	●	26.0	3	2	78	88	103	158	32	42	PT1/8	GPMT090304-U○
TAFL2600F32	●		4		104	114	129	184	32	42	PT1/8	

2/5

## TAFS,TAFM,TAFL

Order number	Stock	DC	L/D	ZNF	LU	LBX	LPR	OAL	DCONMS	DCSFMX	CNT	Insert
TAFS2650F32	●		2		53	62	77	132	32	42	PT1/8	
TAFM2650F32	●	26.5	3	2	79.5	88	103	158	32	42	PT1/8	GPMT090304-U○
TAFL2650F32	●		4		106	114	129	184	32	42	PT1/8	
TAFS2700F32	●		2		54	65	79	134	32	42	PT1/8	
TAFM2700F32	●	27.0	3	2	81	92	106	161	32	42	PT1/8	GPMT090304-U○
TAFL2700F32	●		4		108	119	133	188	32	42	PT1/8	
TAFS2750F32	●		2		55	65	79	134	32	42	PT1/8	
TAFM2750F32	●	27.5	3	2	82.5	92	106	161	32	42	PT1/8	GPMT090304-U○
TAFS2800F32	●		2		56	67	81	136	32	42	PT1/8	
TAFM2800F32	●	28.0	3	2	84	95	109	164	32	42	PT1/8	GPMT11T308-U○
TAFL2800F32	●		4		112	123	137	192	32	42	PT1/8	
TAFS2850F32	●		2		57	67	81	136	32	42	PT1/8	
TAFM2850F32	●	28.5	3	2	85.5	95	109	164	32	42	PT1/8	GPMT11T308-U○
TAFL2850F40	●		4		114	123	137	202	40	50	PT1/8	
TAFS2900F32	●		2		58	70	83	138	32	42	PT1/8	
TAFM2900F32	●	29.0	3	2	87	99	112	167	32	42	PT1/8	GPMT11T308-U○
TAFL2900F32	●		4		116	128	141	196	32	42	PT1/8	
TAFS2950F32	●		2		59	70	83	138	32	42	PT1/8	
TAFM2950F32	●	29.5	3	2	88.5	99	112	167	32	42	PT1/8	GPMT11T308-U○
TAFS3000F32	●		2		60	72	90	145	32	50	PT1/8	
TAFS3000F40	●		2		60	72	90	155	40	50	PT1/4	
TAFM3000F32	●		3		90	102	120	175	32	50	PT1/8	
TAFM3000F40	●	30.0	3	2	90	102	120	185	40	50	PT1/4	GPMT11T308-U○
TAFL3000F32	●		4		120	132	150	205	32	42	PT1/8	
TAFL3000F40	●		4		120	132	150	215	40	50	PT1/4	
TAFS3050F40	●		2		61	72	90	155	40	50	PT1/4	
TAFM3050F40	●	30.5	3	2	91.5	102	120	185	40	50	PT1/4	GPMT11T308-U○
TAFS3100F32	●		2		62	74	92	147	32	50	PT1/8	
TAFS3100F40	●		2		62	74	92	157	40	50	PT1/4	
TAFM3100F32	●		3		93	105	123	178	32	50	PT1/8	
TAFM3100F40	●	31.0	3	2	93	105	123	188	40	50	PT1/4	GPMT11T308-U○
TAFL3100F32	●		4		124	135	154	209	32	42	PT1/8	
TAFL3100F40	●		4		124	136	154	219	40	50	PT1/4	
TAFS3200F32	●		2		64	77	94	149	32	50	PT1/8	
TAFS3200F40	●		2		64	77	94	159	40	50	PT1/4	
TAFM3200F32	●		3		96	109	126	181	32	50	PT1/8	
TAFM3200F40	●	32.0	3	2	96	109	126	191	40	50	PT1/4	GPMT11T308-U○
TAFL3200F32	●		4		128	141	158	213	32	42	PT1/8	
TAFL3200F40	●		4		128	141	158	223	40	50	PT1/4	
TAFS3300F32	●		2		66	79	96	151	32	50	PT1/8	
TAFS3300F40	●		2		66	79	96	161	40	50	PT1/4	
TAFM3300F32	●		3		99	112	129	184	32	50	PT1/8	
TAFM3300F40	●	33.0	3	2	99	112	129	194	40	50	PT1/4	GPMT11T308-U○
TAFL3300F32	●		4		132	145	162	217	32	42	PT1/8	
TAFL3300F40	●		4		132	145	162	227	40	50	PT1/4	
TAFS3400F32	●		2		68	82	98	153	32	50	PT1/8	
TAFS3400F40	●		2		68	82	98	163	40	50	PT1/4	
TAFM3400F32	●		3		102	116	132	187	32	50	PT1/8	
TAFM3400F40	●	34.0	3	2	102	116	132	197	40	50	PT1/4	GPMT11T308-U○
TAFL3400F32	●		4		136	150	166	231	32	42	PT1/8	
TAFL3400F40	●		4		136	150	166	231	40	50	PT1/4	

3/5

## TAFS,TAFM,TAFL

Order number	Stock	DC	L/D	ZNF	LU	LBX	LPR	OAL	DCONMS	DCSFMX	CNT	Insert
TAFS3500F32	●		2		70	84	100	155	32	50	PT1/8	GPMT140408-U○
TAFS3500F40	●		2		70	84	100	165	40	50	PT1/4	
TAFM3500F32	●	35.0	3	2	105	119	135	190	32	50	PT1/8	
TAFM3500F40	●		3		105	119	135	200	40	50	PT1/4	
TAFL3500F32	●		4		140	154	170	235	32	42	PT1/8	
TAFL3500F40	●		4		140	154	170	235	40	50	PT1/4	
TAFS3600F32	□		2		72	86	102	157	32	50	PT1/8	GPMT140408-U○
TAFS3600F40	□		2		72	86	102	167	40	50	PT1/4	
TAFM3600F32	□	36.0	3	2	108	122	138	193	32	50	PT1/8	
TAFM3600F40	□		3		108	122	138	203	40	50	PT1/4	
TAFL3600F32	□		4		144	158	174	229	32	42	PT1/8	
TAFL3600F40	□		4		144	158	174	239	40	50	PT1/4	
TAFS3700F32	□		2		74	89	104	159	32	50	PT1/8	GPMT140408-U○
TAFS3700F40	□		2		74	89	104	169	40	50	PT1/4	
TAFM3700F32	□	37.0	3	2	111	126	141	196	32	50	PT1/8	
TAFM3700F40	□		3		111	126	141	206	40	50	PT1/4	
TAFL3700F32	□		4		148	163	178	233	32	42	PT1/8	
TAFL3700F40	□		4		148	163	178	243	40	50	PT1/4	
TAFS3750F32	□		2		75	89	104	159	32	50	PT1/8	GPMT140408-U○
TAFS3750F40	□		2		75	89	104	169	40	50	PT1/4	
TAFM3750F32	□	37.5	3	2	112.5	126	141	196	32	50	PT1/8	
TAFM3750F40	□		3		112.5	126	141	206	40	50	PT1/4	
TAFL3750F32	□		4		150	163	178	233	32	42	PT1/8	
TAFL3750F40	□		4		150	163	178	243	40	50	PT1/4	
TAFS3800F32	□		2		76	91	106	161	32	50	PT1/8	GPMT140408-U○
TAFS3800F40	□		2		76	91	106	171	40	50	PT1/4	
TAFM3800F32	□	38.0	3	2	114	129	144	199	32	50	PT1/8	
TAFM3800F40	□		3		114	129	144	209	40	50	PT1/4	
TAFL3800F32	□		4		152	167	182	247	32	42	PT1/8	
TAFL3800F40	□		4		152	167	182	247	40	50	PT1/4	
TAFS3900F32	□		2		78	94	108	163	32	50	PT1/8	GPMT140408-U○
TAFS3900F40	□		2		78	94	108	173	40	50	PT1/4	
TAFM3900F32	□	39.0	3	2	117	133	147	202	32	50	PT1/8	
TAFM3900F40	□		3		117	133	147	212	40	50	PT1/4	
TAFL3900F32	□		4		156	172	186	251	32	42	PT1/8	
TAFL3900F40	□		4		156	172	186	251	40	50	PT1/4	
TAFS4000F32	□		2		80	96	110	165	32	50	PT1/8	GPMT140408-U○
TAFS4000F40	□		2		80	96	110	175	40	50	PT1/4	
TAFM4000F32	□	40.0	3	2	120	136	150	205	32	50	PT1/8	
TAFM4000F40	□		3		120	136	150	215	40	50	PT1/4	
TAFL4000F32	□		4		160	176	190	245	32	42	PT1/8	
TAFL4000F40	□		4		160	176	190	255	40	50	PT1/4	
TAFS4100F40	□		2		82	98	112	177	40	50	PT1/4	GPMT140408-U○
TAFM4100F40	□	41.0	3	2	123	139	153	218	40	50	PT1/4	
TAFL4100F40	□		4		164	180	194	259	40	50	PT1/4	
TAFS4200F40	□		2		84	101	114	179	40	50	PT1/4	GPMT140408-U○
TAFM4200F40	□	42.0	3	2	126	143	156	221	40	50	PT1/4	
TAFL4200F40	□		4		168	185	198	263	40	50	PT1/4	
TAFS4300F40	□		2		86	103	116	181	40	50	PT1/4	GPMT140408-U○
TAFM4300F40	□	43.0	3	2	129	146	159	224	40	50	PT1/4	
TAFL4300F40	□		4		172	189	202	267	40	50	PT1/4	

4/5

## TAFS,TAFM,TAFL

Order number	Stock	DC	L/D	ZNF	LU	LBX	LPR	OAL	DCONMS	DCSFMX	CNT	Insert
TAFS4400F40	<input type="checkbox"/>		2		88	106	118	183	40	50	PT1/4	
TAFM4400F40	<input type="checkbox"/>	44.0	3	2	132	150	162	227	40	50	PT1/4	GPMT140408-U
TAFL4400F40	<input type="checkbox"/>		4		176	194	206	271	40	50	PT1/4	
TAFS4500F40	<input type="checkbox"/>		2		90	108	120	185	40	54	PT1/4	
TAFM4500F40	<input type="checkbox"/>	45.0	3	2	135	153	165	230	40	54	PT1/4	GPMT140408-U
TAFL4500F40	<input type="checkbox"/>		4		180	198	210	275	40	54	PT1/4	
TAFS4600F40	<input type="checkbox"/>		2		92	110	122	187	40	54	PT1/4	
TAFM4600F40	<input type="checkbox"/>	46.0	3	2	138	156	168	233	40	54	PT1/4	GPMT140408-U
TAFL4600F40	<input type="checkbox"/>		4		184	202	214	279	40	54	PT1/4	
TAFS4700F40	<input type="checkbox"/>		2		94	113	124	189	40	54	PT1/4	
TAFM4700F40	<input type="checkbox"/>	47.0	3	2	141	160	171	236	40	54	PT1/4	GPMT140408-U
TAFL4700F40	<input type="checkbox"/>		4		188	207	218	283	40	54	PT1/4	
TAFS4800F40	<input type="checkbox"/>		2		96	115	126	191	40	54	PT1/4	
TAFM4800F40	<input type="checkbox"/>	48.0	3	2	144	163	174	239	40	54	PT1/4	GPMT140408-U
TAFL4800F40	<input type="checkbox"/>		4		192	211	222	287	40	54	PT1/4	
TAFS4900F40	<input type="checkbox"/>		2		98	118	133	198	40	58	PT1/4	
TAFM4900F40	<input type="checkbox"/>	49.0	3	4	147	167	182	247	40	58	PT1/4	GPMT090304-U
TAFL4900F40	<input type="checkbox"/>		4		196	216	231	296	40	58	PT1/4	
TAFS5000F40	<input type="checkbox"/>		2		100	120	135	200	40	58	PT1/4	
TAFM5000F40	<input type="checkbox"/>	50.0	3	4	150	170	185	250	40	58	PT1/4	GPMT090304-U
TAFL5000F40	<input type="checkbox"/>		4		200	220	235	300	40	58	PT1/4	
TAFS5100F40	<input type="checkbox"/>		2		102	122	137	202	40	58	PT1/4	
TAFM5100F40	<input type="checkbox"/>	51.0	3	4	153	173	188	253	40	58	PT1/4	GPMT090304-U
TAFL5100F40	<input type="checkbox"/>		4		204	224	239	304	40	58	PT1/4	
TAFS5200F40	<input type="checkbox"/>		2		104	125	139	204	40	58	PT1/4	
TAFM5200F40	<input type="checkbox"/>	52.0	3	4	156	177	191	256	40	58	PT1/4	GPMT090304-U
TAFL5200F40	<input type="checkbox"/>		4		208	229	243	308	40	58	PT1/4	
TAFS5300F40	<input type="checkbox"/>		2		106	127	141	206	40	63	PT1/4	
TAFM5300F40	<input type="checkbox"/>	53.0	3	4	159	180	194	259	40	63	PT1/4	GPMT090304-U
TAFL5300F40	<input type="checkbox"/>		4		212	233	247	312	40	63	PT1/4	
TAFS5400F40	<input type="checkbox"/>		2		108	128	143	208	40	63	PT1/4	
TAFM5400F40	<input type="checkbox"/>	54.0	3	4	162	182	197	262	40	63	PT1/4	GPMT090304-U
TAFL5400F40	<input type="checkbox"/>		4		216	236	251	316	40	63	PT1/4	
TAFS5500F40	<input type="checkbox"/>		2		110	130	145	210	40	63	PT1/4	
TAFM5500F40	<input type="checkbox"/>	55.0	3	4	165	185	200	265	40	63	PT1/4	GPMT090304-U
TAFL5500F40	<input type="checkbox"/>		4		220	240	255	320	40	63	PT1/4	
TAFS5600F40	<input type="checkbox"/>		2		112	132	147	212	40	63	PT1/4	
TAFM5600F40	<input type="checkbox"/>	56.0	3	4	168	188	203	268	40	63	PT1/4	GPMT090304-U
TAFL5600F40	<input type="checkbox"/>		4		224	244	259	324	40	63	PT1/4	

5/5



# TAFS, TAFM, TAFL

## INCREASED RIGIDITY TYPE DESIGN

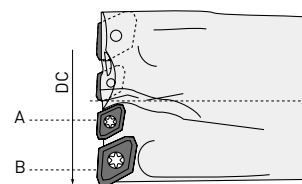
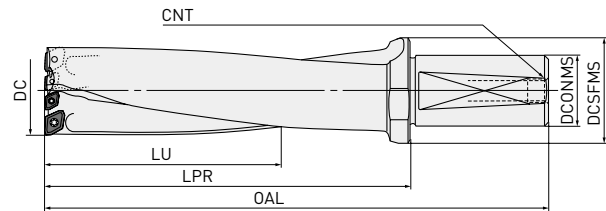
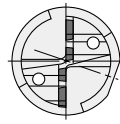





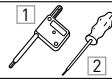

Order number	Stock	DC	L/D	ZNF	DCONMS	DCSFMS	CNT	OAL	LPR	LU	Inner/ Outer type	Insert
TAFS5000F40-E	<input type="checkbox"/>		2	4	40	58	PT1/4	200	135	120	A B	GPMT090304-U $\odot$ GPMT11T308-U $\odot$
TAFM5000F40-E	<input type="checkbox"/>	50.0	3	4	40	58	PT1/4	250	185	170	A B	GPMT090304-U $\odot$ GPMT11T308-U $\odot$
TAFL5000F40-E	<input type="checkbox"/>		4	4	40	58	PT1/4	300	235	220	A B	GPMT090304-U $\odot$ GPMT11T308-U $\odot$
TAFS5100F40-E	<input type="checkbox"/>		2	4	40	58	PT1/4	202	137	122	A B	GPMT090304-U $\odot$ GPMT11T308-U $\odot$
TAFM5100F40-E	<input type="checkbox"/>	51.0	3	4	40	58	PT1/4	253	188	173	A B	GPMT090304-U $\odot$ GPMT11T308-U $\odot$
TAFL5100F40-E	<input type="checkbox"/>		4	4	40	58	PT1/4	304	239	224	A B	GPMT090304-U $\odot$ GPMT11T308-U $\odot$
TAFS5200F40-E	<input type="checkbox"/>		2	4	40	58	PT1/4	204	139	125	A B	GPMT090304-U $\odot$ GPMT11T308-U $\odot$
TAFM5200F40-E	<input type="checkbox"/>	52.0	3	4	40	58	PT1/4	256	191	177	A B	GPMT090304-U $\odot$ GPMT11T308-U $\odot$
TAFL5200F40-E	<input type="checkbox"/>		4	4	40	58	PT1/4	308	243	229	A B	GPMT090304-U $\odot$ GPMT11T308-U $\odot$
TAFS5300F40-E	<input type="checkbox"/>		2	4	40	63	PT1/4	206	141	127		
TAFM5300F40-E	<input type="checkbox"/>	53.0	3	4	40	63	PT1/4	259	194	180	A	GPMT11T308-U $\odot$
TAFL5300F40-E	<input type="checkbox"/>		4	4	40	63	PT1/4	312	247	233		
TAFS5400F40-E	<input type="checkbox"/>		2	4	40	63	PT1/4	208	134	128		
TAFM5400F40-E	<input type="checkbox"/>	54.0	3	4	40	63	PT1/4	262	197	182	A	GPMT11T308-U $\odot$
TAFL5400F40-E	<input type="checkbox"/>		4	4	40	63	PT1/4	316	251	236		
TAFS5500F40-E	<input type="checkbox"/>		2	4	40	63	PT1/4	210	145	130		
TAFM5500F40-E	<input type="checkbox"/>	55.0	3	4	40	63	PT1/4	265	200	185	A	GPMT11T308-U $\odot$
TAFL5500F40-E	<input type="checkbox"/>		4	4	40	63	PT1/4	320	255	240		
TAFS5600F40-E	<input type="checkbox"/>		2	4	40	63	PT1/4	212	147	132		
TAFM5600F40-E	<input type="checkbox"/>	56.0	3	4	40	63	PT1/4	268	203	188	A	GPMT11T308-U $\odot$
TAFL5600F40-E	<input type="checkbox"/>		4	4	40	63	PT1/4	324	259	244		

# TAFS, TAFM, TAFL

## SPARE PARTS

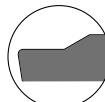
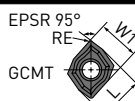
Tool holder type		
	Clamp screw	Wrench
GCMT040204-U $\odot$	TS2	1 TKY06F
GPMT060204-U $\odot$	TS2	1 TKY06F
GPMT070204-U $\odot$	TS25	1 TKY08F
GPMT090304-U $\odot$	TS3	1 TKY08F
GPMT11T308-U $\odot$	TS4	2 TKY15D
GPMT140408-U $\odot$	TS5	2 TKY25D
GPMT090304-U $\odot$	TS3	1 TKY08F

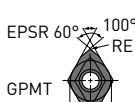
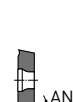
## INSERTS

Order number	VP15TF	UP20M	GP20M	UE6020	US735	L	W1	IC	S	RE	Drill diameter	Shape
<b>U1</b>												
GCMT040204-U1	●					5.0	4.7	—	2.38	0.4	Ø 12 – 14.5	  
GPMT060204-U1	●			●	●	—	—	5.56	2.38	0.4	Ø 15 – 17.5	
GPMT070204-U1	●			●	●	—	—	6.35	2.38	0.4	Ø 18 – 22.5	
GPMT090304-U1	●			●	●	—	—	7.94	3.18	0.4	Ø 23 – 27.5	
GPMT090304-U1	●			●	●	—	—	7.94	3.18	0.4	Ø 49 – 56	
GPMT11T308-U1	●			●	●	—	—	9.525	3.97	0.8	Ø 28 – 34	
GPMT140408-U1	●			●	●	—	—	12.70	4.76	0.8	Ø 35 – 48	
<b>U2</b>												
GCMT040204-U2	●		●			5.0	4.7	—	2.38	0.4	Ø 12 – 14.5	  
GPMT060204-U2	●	●		●	●	—	—	5.56	2.38	0.4	Ø 15 – 17.5	
GPMT070204-U2	●	●		●	●	—	—	6.35	2.38	0.4	Ø 18 – 22.5	
GPMT090304-U2	●	●		●	●	—	—	7.94	3.18	0.4	Ø 23 – 27.5	
GPMT090304-U2	●	●		●	●	—	—	7.94	3.18	0.4	Ø 49 – 56	
GPMT11T308-U2	●	●		●	●	—	—	9.525	3.97	0.8	Ø 28 – 34	
GPMT140408-U2	●	●		●	●	—	—	12.70	4.76	0.8	Ø 35 – 48	
<b>U3</b>												
GPMT060204-U3	●			●	●	—	—	5.56	2.38	0.4	Ø 15 – 17.5	  
GPMT070204-U3	●			●	●	—	—	6.35	2.38	0.4	Ø 18 – 22.5	
GPMT090304-U3	●			●	●	—	—	7.94	3.18	0.4	Ø 23 – 27.5	
GPMT090304-U3	●			●	●	—	—	7.94	3.18	0.4	Ø 49 – 56	
GPMT11T308-U3	●			●	●	—	—	9.525	3.97	0.8	Ø 28 – 34	
GPMT140408-U3	●			●	●	—	—	12.70	4.76	0.8	Ø 35 – 48	

1/1

146 

# TAFS, TAFM, TAFL

## CHIPBREAKER RECOMMENDATION

Material	Grade			
	1st recommendation		2nd recommendation	
	GCMT	GPMT	GCMT	GPMT
P Mild steel	U1	U1		
			U2	U2
				U3
			U1	U1
Carbon steel Alloy steel Alloy tool steel	U2	U2		U2
				U3
			U1	U1
M Stainless steel	U2	U2		
				U3
K Gray cast iron Ductile cast iron	U2	U3	U1	U1
				U2

1/1

## INSERT GRADE RECOMMENDATION

Material	Grade			
	1st recommendation		2nd recommendation	
	GCMT	GPMT	GCMT	GPMT
P Mild steel			VP15TF	VP15TF
	UP20M	UP20M		
			GP20M	
				UE6020
				US735
Carbon steel Alloy steel Alloy tool steel	VP15TF	VP15TF		
			UP20M	UP20M
	GP20M	UE6020	GP20M	VP15TF
				US735
M Stainless steel	VP15TF	VP15TF		
			UP20M	UP20M
	GP20M	US735	GP20M	
K Gray cast iron Ductile cast iron				UE6020
	VP15TF			
			UP20M	UP20M
	GP20M			UE6020
				US735
			VP15TF	

1/1

# TAFS, TAFM, TAFL

## RECOMMENDED CUTTING CONDITIONS

Material	Hardness	Vc				Vc					
		L/D = 2, 3		L/D = 4		Drill diameter					
		Ø 12 - Ø 14.5	Ø 15 -	Ø 16 -		Ø 12 - Ø 14.5	Ø 15 - Ø 22.5	Ø 23 - Ø 34	Ø 35 - Ø 48	Ø 49 - Ø 56	
P	Mild steel	≤180HB	150 (100 - 200)	200 (150 - 300)	140 (100 - 200)	U1	0.06 (0.04 - 0.10)	0.07 (0.04 - 0.10)	0.08 (0.04 - 0.10)	0.10 (0.04 - 0.12)	0.08 (0.04 - 0.10)
						U2	0.06 (0.04 - 0.10)	0.08 (0.04 - 0.12)	0.10 (0.04 - 0.12)	0.12 (0.04 - 0.14)	0.10 (0.04 - 0.12)
						U3	—	0.08 (0.04 - 0.12)	0.10 (0.04 - 0.12)	0.12 (0.04 - 0.14)	0.10 (0.04 - 0.12)
	Carbon steel	180 - 280 HB	120 (80 - 160)	150 (120 - 180)	100 (80 - 120)	U1	0.06 (0.04 - 0.10)	0.09 (0.06 - 0.12)	0.12 (0.08 - 0.14)	0.15 (0.08 - 0.18)	0.12 (0.08 - 0.14)
						U2	0.06 (0.04 - 0.10)	0.12 (0.06 - 0.14)	0.14 (0.08 - 0.18)	0.17 (0.08 - 0.20)	0.14 (0.08 - 0.18)
						U3	—	0.12 (0.06 - 0.14)	0.14 (0.08 - 0.18)	0.17 (0.08 - 0.20)	0.14 (0.08 - 0.18)
	Alloy steel	180 - 280 HB	120 (80 - 160)	150 (120 - 180)	100 (80 - 120)	U1	0.06 (0.04 - 0.10)	0.08 (0.06 - 0.10)	0.09 (0.06 - 0.12)	0.11 (0.06 - 0.14)	0.09 (0.06 - 0.12)
						U2	0.06 (0.04 - 0.10)	0.10 (0.06 - 0.12)	0.12 (0.08 - 0.16)	0.14 (0.08 - 0.18)	0.12 (0.08 - 0.16)
						U3	—	0.10 (0.06 - 0.12)	0.12 (0.08 - 0.16)	0.14 (0.08 - 0.18)	0.12 (0.08 - 0.16)
M	Stainless steel	≤200HB	100 (80 - 120)	150 (120 - 200)	110 (80 - 140)	U1	0.07 (0.04 - 0.10)	0.07 (0.04 - 0.10)	0.08 (0.04 - 0.10)	0.10 (0.04 - 0.12)	0.08 (0.04 - 0.10)
						U2	0.07 (0.04 - 0.10)	0.08 (0.04 - 0.12)	0.10 (0.04 - 0.14)	0.12 (0.04 - 0.16)	0.10 (0.04 - 0.14)
						U3	—	0.08 (0.04 - 0.12)	0.10 (0.04 - 0.14)	0.12 (0.04 - 0.16)	0.10 (0.04 - 0.14)
K	Cast iron	Tensile strength ≤350MPa	120 (80 - 160)	150 (120 - 180)	140 (110 - 160)	U1	0.07 (0.06 - 0.10)	0.07 (0.06 - 0.10)	0.10 (0.04 - 0.14)	0.10 (0.06 - 0.14)	0.10 (0.06 - 0.14)
						U2	0.07 (0.06 - 0.10)	0.15 (0.10 - 0.18)	0.20 (0.10 - 0.25)	0.20 (0.10 - 0.25)	0.20 (0.10 - 0.25)
						U3	—	0.15 (0.10 - 0.18)	0.20 (0.10 - 0.25)	0.20 (0.10 - 0.25)	0.20 (0.10 - 0.25)
	Ductile cast iron	Tensile strength ≤450MPa	120 (80 - 150)	150 (120 - 180)	100 (80 - 120)	U1	0.06 (0.04 - 0.10)	0.07 (0.06 - 0.10)	0.10 (0.06 - 0.14)	0.10 (0.06 - 0.14)	0.10 (0.06 - 0.14)
						U2	0.06 (0.04 - 0.10)	0.12 (0.08 - 0.14)	0.15 (0.08 - 0.20)	0.18 (0.08 - 0.20)	0.15 (0.08 - 0.20)
						U3	—	0.12 (0.08 - 0.14)	0.15 (0.08 - 0.20)	0.18 (0.08 - 0.20)	0.15 (0.08 - 0.20)

1/1

1. When using drills for l/d= 4, the feed should be reduced to 80 % of the above recommendations.

# TAFS, TAFM, TAFL

## JUST FIT SLEEVE [JFS]

A sleeve for the shank of the drill to allow the cutting diameter to be increased.

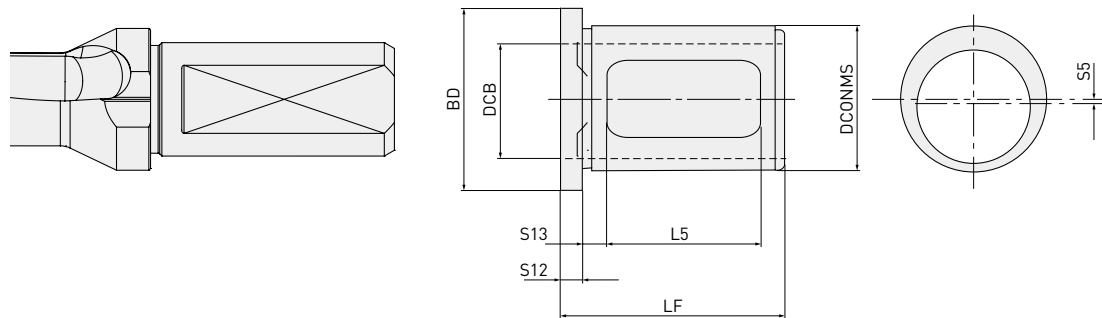

Order number	Set order number	Stock	DCB	DCONMS	BD	LF	L5	* Increase (S5x2)	Suitable TAF type drill
JFS2520-10	JFS-1	●	20	25	33	43	30	0.1	TAFS/M/L1200F20 - TAFS/M/L1550F20
JFS2520-20		●	20	25	33	43	30	0.2	
JFS2520-30		●	20	25	33	43	30	0.3	
JFS2520-40		●	20	25	33	43	30	0.4	
JFS2520-50		●	20	25	33	43	30	0.5	
JFS3225-10	JFS-2	●	25	32	40	50	34	0.1	TAFS/M/L1600F25 - TAFS/M/L2450F25
JFS3225-20		●	25	32	40	50	34	0.2	
JFS3225-30		●	25	32	40	50	34	0.3	
JFS3225-40		●	25	32	40	50	34	0.4	
JFS3225-50		●	25	32	40	50	34	0.5	
JFS4032-10	JFS-3	●	32	40	48	55	40	0.1	TAFS/M/L2500F32 - TAFS/M/L2950F32
JFS4032-20		●	32	40	48	55	40	0.2	
JFS4032-30		●	32	40	48	55	40	0.3	
JFS4032-40		●	32	40	48	55	40	0.4	
JFS4032-50		●	32	40	48	55	40	0.5	
JFS5040-10	JFS-4	●	40	50	68	65	50	0.1	AFS/M/L2850F40 - TAFS/M/L5600F40 TAFS/M/L5000F40-E
JFS5040-20		●	40	50	68	65	50	0.2	
JFS5040-30		●	40	50	68	65	50	0.3	
JFS5040-40		●	40	50	68	65	50	0.4	
JFS5040-50		●	40	50	68	65	50	0.5	

1/1

\* Increase: Size of the increased cutting diameter.

# TAFS, TAFM, TAFL

## GUIDELINE FOR SELECTING A JUST FIT SLEEVE

**Desired = (Drill Ø + Increase of JFS) + 0.1 mm**

(Eg.) Desired diameter is 20.3 mm (oversize is taken as 0.1 mm).

$$\text{Ø } 20.3 = (\text{TAFS/M/L2000F25} + \text{JFS3225-20}) + 0.1$$

20 mm Drill

Using JFS an increase  
of 0.2 mm

Oversize

### Tool selected

Drill: TAFM2000F25

Just Fit Sleeve [JFS]: JFS3225-20

1. Oversize can vary due to the cutting conditions used, please use the above as a guideline.

## ORDERING THE JUST FIT SLEEVE

### PURCHASING METHOD 1

Oversize can vary due to the cutting conditions used. Therefore it is recommended to purchase as a set. When placing an order, please use the Set order number. (5 sleeves/set)

### PURCHASING METHOD 2

It is possible to order individually. When placing an order, please use the individual order number.

## APPLICATION OF JUST FIT SLEEVE

When inserting the drill into the side lock holder, align the V groove on the outer peripheral edge of the drill flange, as well as the round holes of the outer peripheral edge of the sleeve flange and the screws of the side lock holder for fixing the drill. (If the drill does not have a V groove, align the notch of the drill shank with the round holes of the sleeve.)

Insert screws A of the side lock holder directly to the open window of the sleeve and fix the drill. Tighten screw B to a degree so as not to damage the sleeve.

- Fine adjustments cannot be made for the diameter of the sleeve.
- Cannot be used with collect chuck type holders.

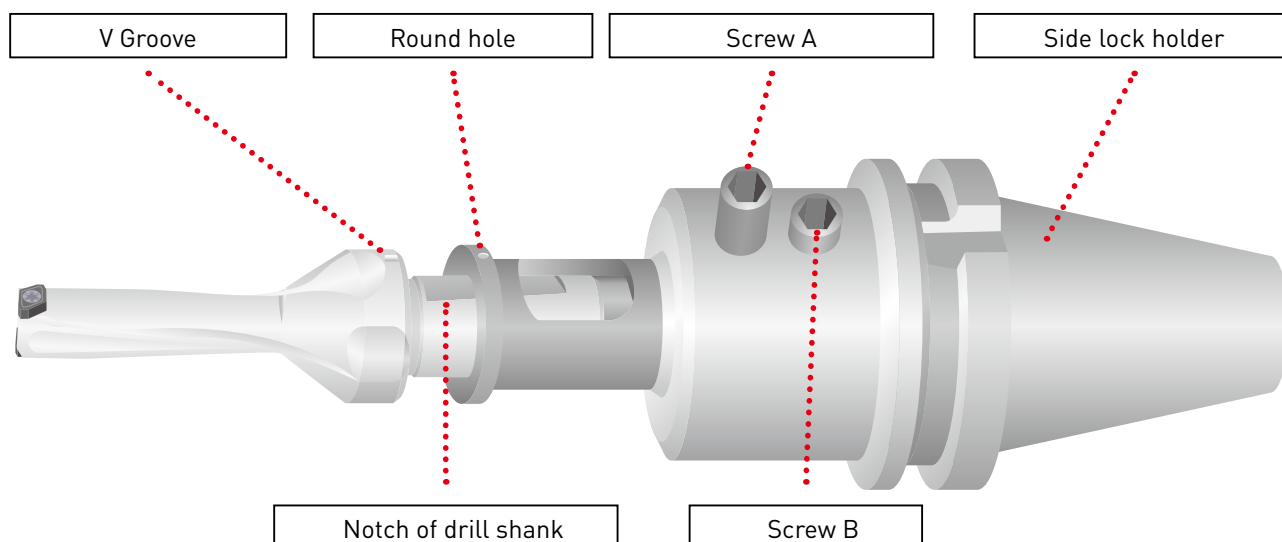

# TAFS, TAFM, TAFL

## APPLICATION EXAMPLES

### ANGLED FACE DRILLING

Material	DIN 42CrMo4 (180 – 280 HB)	
Tool	Ø 20 (3 x D)	
Vc (m/min)	80	
f (mm/rev)	0.08	
<b>Tool</b>	<b>L (mm)</b>	<b>L (max.)</b>
<b>TAF</b>	0.11	Good
Conventional A	0.17	Good
Conventional B	0.13	Inner and outer cutting edge fractures

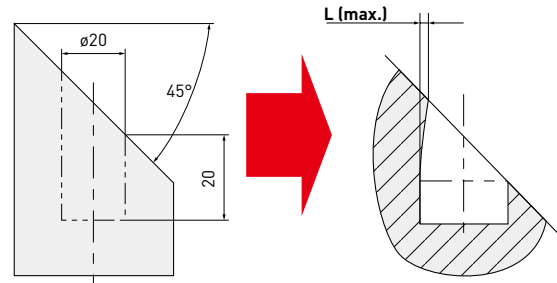

### ROUND WORKPIECE DRILLING

Material	DIN Ck50 (120 HB – 180 HB)	
Tool	Ø 20 (3 x D)	
Vc (m/min)	50, 80, 100	
f (mm/rev)	0.08 Initial cutting 0.05	

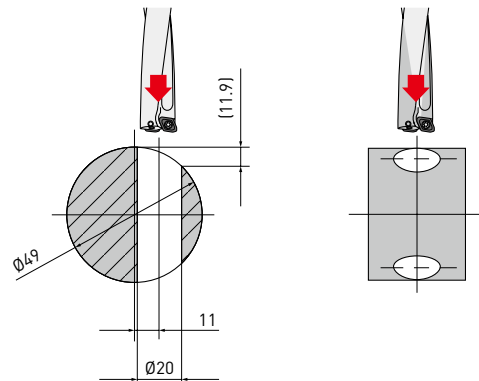

1. The inner cutting edge of a conventional drill fractured.

### THROUGH HOLE DRILLING

Material	DIN Ck50 (120 – 180 HB)	
Tool	Ø 20 (3 x D)	
Vc (m/min)	80	
f (mm/rev)	0.08	

Drill oversize (to measured drill diameter)

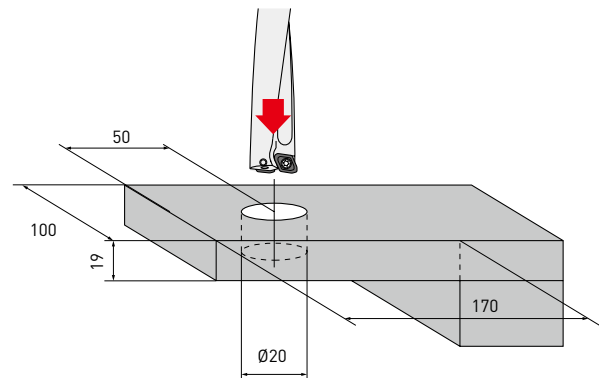
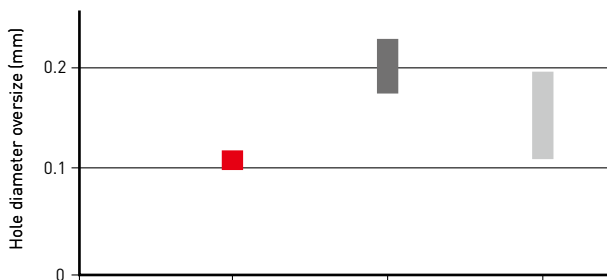

# TAFS, TAFM, TAFL

## APPLICATIONS

- Please ensure the highest rigidity possible exists in both machine set up and workholding.
- Refer to the following graph on the right for coolant pressure and volume. Coolant is an important factor in the efficient use of these drills.
- Cannot be used for stack drilling.  
In common with many indexable insert drills, these drills produce a round disc on exit which unless evacuated may cause the drill to fracture.

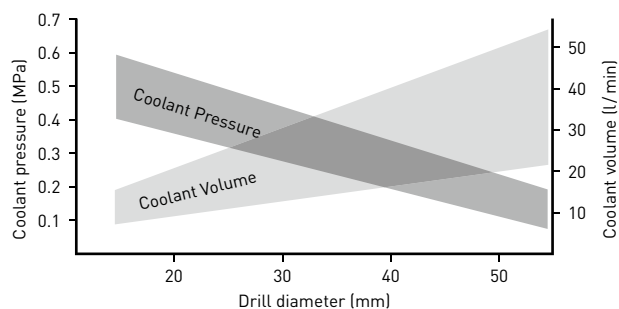

### USE ON A LATHE

The inner cutting edge must be positioned between 0 – 0.2 mm over centre.

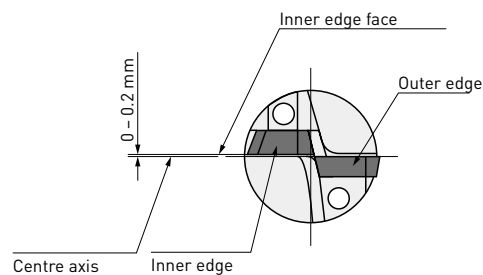

To adjust the hole diameter by off-setting the drill, the outer cutting edge and machine axis must be set parallel.

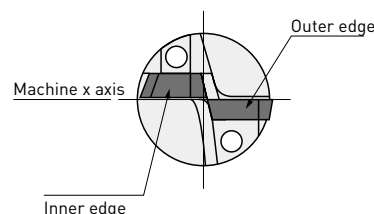

When producing an oversize hole.

The drill offset should be no more than 2 % of the diameter. It is not possible to produce an undersized hole.

When through hole drilling on a lathe the disc produced by the drill exiting the workpiece may be expelled at high velocity. To reduce the danger of injury or damage a cover guard is highly recommended.

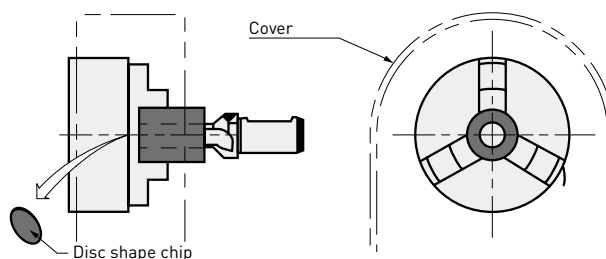





# WORLDWIDE

## **MITSUBISHI MATERIALS - METALWORKING SOLUTIONS COMPANY A SYNERGY FOR SUCCESS**

The Metalworking Solutions division of Mitsubishi Materials is dedicated to the development and processing of metals, cutting materials, coatings and precision tools. Profound know-how and many years of experience in manufacturing technology makes Mitsubishi Materials one of the leading suppliers in the precision cutting tool market.

The company's global market presence, with headquarters and sales offices in Japan, Europe, India, Brazil, China, Thailand, Mexico and the US, as well as a broad network of international distributors, ensures a targeted, comprehensive service.

Information exchange and technology transfer, open communication and growing synergies guarantee maximum performance and sustainable customer success.

# METALWORKING SOLUTIONS COMPANY

---

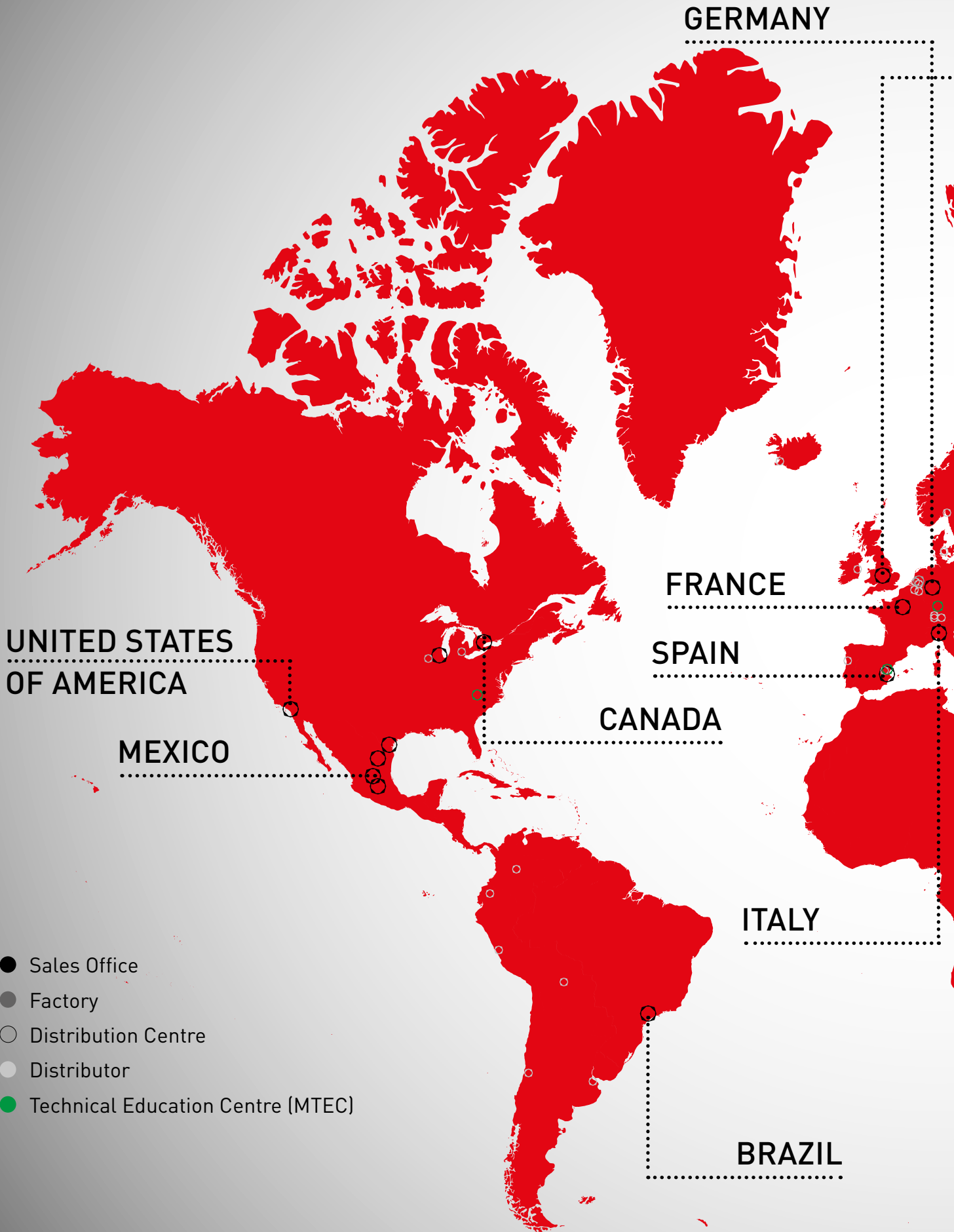

POLAND

U.K.

JAPAN

CHINA

THAILAND

INDIA

TURKEY

















#### GERMANY

MMC HARTMETALL GMBH  
Comeniusstr. 2 . 40670 Meerbusch  
Phone +49 2159 91890 . Fax +49 2159 918966  
Email admin@mmchg.de

#### UK Office

MMC HARDMETAL UK LTD  
1 Centurion Court, Centurion Way  
Tamworth, B77 5PN  
Phone +44 1827 312312  
Email sales@mitsubishicarbide.co.uk

#### UK Deliveries/Returns

Unit 4 B5K Business Park, Quartz Close  
Tamworth, B77 4GR

#### SPAIN

MITSUBISHI MATERIALS ESPAÑA, S.A.  
Calle Emperador 2 . 46136 Museros/Valencia  
Phone +34 96 1441711  
Email comercial@mmevalencia.es

#### FRANCE

MMC METAL FRANCE S.A.R.L.  
6, Rue Jacques Monod . 91400 Orsay  
Phone +33 1 69 35 53 53 . Fax +33 1 69 35 53 50  
Email mmfsales@mmc-metal-france.fr

#### POLAND

MMC HARDMETAL POLAND SP. Z O.O  
Al. Armii Krajowej 61 . 50 - 541 Wrocław  
Phone +48 71335 1620 . Fax +48 71335 1621  
Email sales@mitsubishicarbide.com.pl

#### ITALY

MMC ITALIA S.R.L.  
Viale Certosa 144 . 20156 Milano  
Phone +39 0293 77031 . Fax +39 0293 589093  
Email info@mmc-italia.it

#### TURKEY

MMC HARTMETALL GMBH ALMANYA - İZMİR MERKEZ ŞUBESİ  
Adalet Mahallesi Anadolu Caddesi No: 41-1 . 15001 35530 Bayraklı/İzmir  
Phone +90 232 5015000 . Fax +90 232 5015007  
Email info@mmchg.com.tr

[europe.mmc-carbide.com](http://europe.mmc-carbide.com)

