

APX3000/4000

A NEW GENERATION OF
HIGH PERFORMANCE CUTTERS



APX3000/4000

MULTI-FUNCTIONAL MILLING CUTTER

MULTI-FUNCTIONAL

The APX is highly effective in various 3D machining operations including excellent ramping capabilities.

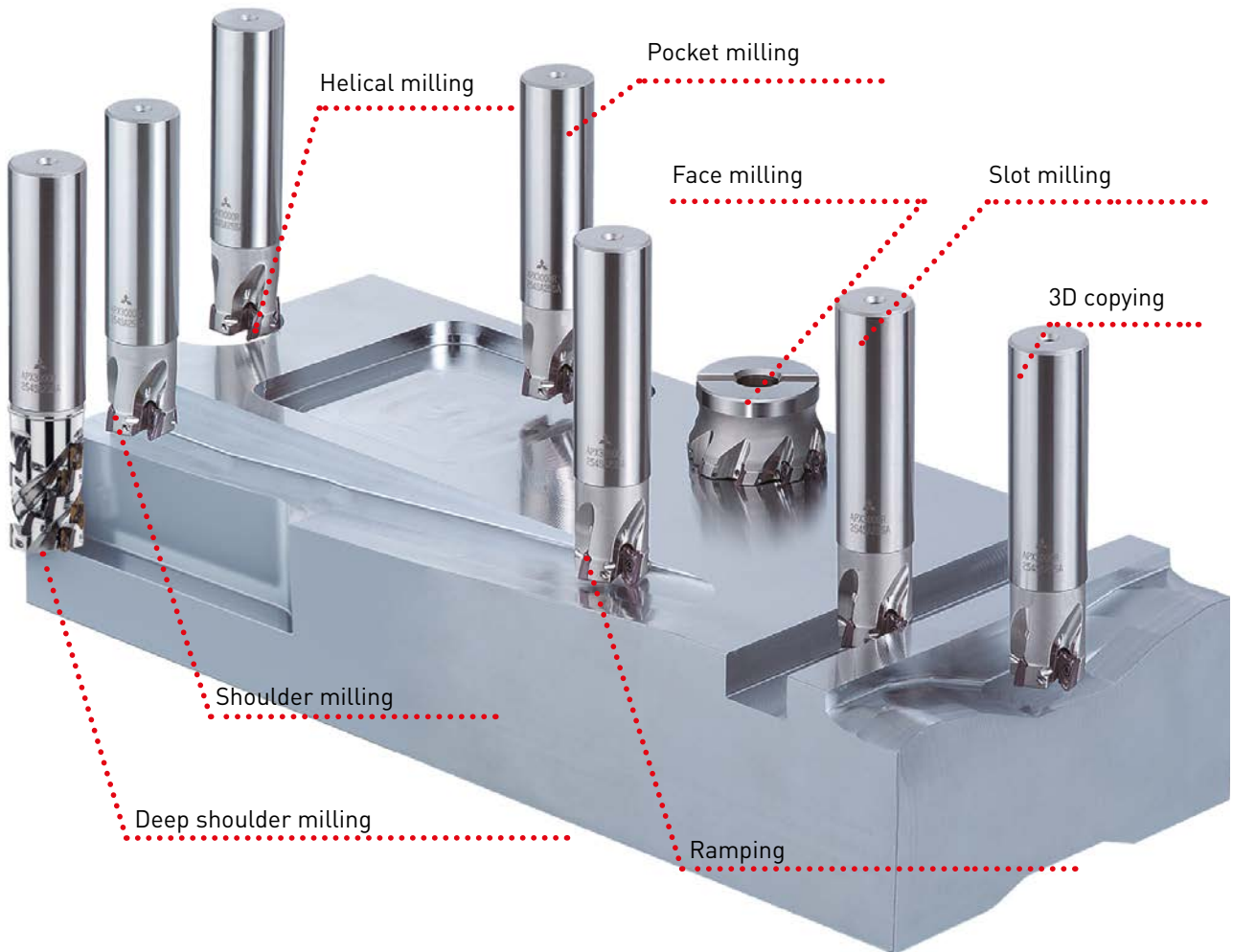

HIGH RIGIDITY CUTTER BODIES

Rigidity has been increased by using a larger amount of backing metal behind the insert. Resistance to corrosion and abrasion on the cutter bodies made possible by using a superior highly heat resistant alloy and a special surface treatment. The cutter bodies are designed with through coolant holes to improve cooling and chip disposal.



EFFECTIVE DEEP HOLE MACHINING

APX3000/4000, an extra long shank type is now available for difficult to reach applications.

(Long, extra long shank type)



(Standard shank type)



INSERT GRADES FOR A WIDE RANGE OF MATERIALS

APPLICATION RANGE

P	M	K	S	N	H
P10	M10	K10	S10	N10	H10
P20	M20	K20	S20	N20	H20
P30	M30	K30	S30	N30	H30
P40	M40	K40	S40	N40	H40

MP6120

for general milling of steel

MP6130

for interrupted milling of steel

MP7130

for stable milling of stainless steel

MC5020

for general milling of cast iron

MP9120

for general milling of HRSA and titanium alloy

MP9130

for interrupted general milling of HRSA and titanium alloy

TF15

for general milling of aluminium

VP15TF

Stable machining properties are enabled when the coating is combined with a high wear and fracture resistant carbide substrate

VP20RT

Ideal for heavy interrupted cutting of stainless and general steels because of the excellent fracture resistance properties

LOW CUTTING RESISTANCE INSERTS

Advanced simulation technology has been utilized to develop the inserts. Efficient machining on low rigidity machines and workpieces is now possible and is ideal for thin wall or extended reach applications.

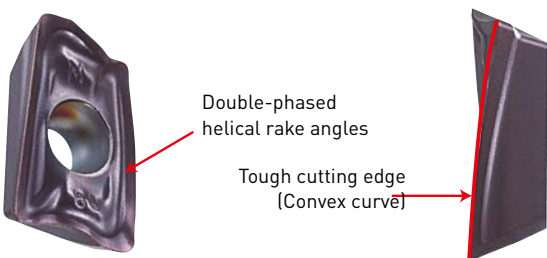

INSERT SIZE

APX4000	APX3000
15mm Max. Depth of Cut	10mm Max. Depth of Cut



IDEAL HEAT DISPOSAL AND CHIP CONTROL

Heat generated during cutting has been reduced due to the APX's special geometry. Ideal chip shape formed by the insert for easy disposal.

CUTTING CONDITIONS

Material	42CrMo4
Tool	APX3000R254SA25SA
Insert	AOMT123608PEER-M
Grade	MP6120
Cutting Speed Vc (m/min)	200
Feed per Tooth fz (mm/t.)	0.2
Depth of Cut ap (mm)	6.0
Width of Cut ae (mm)	6.0

INSERT CHIP BREAKER

General Use M breaker (APX3000, APX4000)	Strong Cutting Edge Type H breaker (APX3000, APX4000)	For Aluminum alloy (Ground & Polished) GM breaker (APX3000)
--	---	--

Rake angle: 25° Rake angle: 7° Rake angle: 25°



Rake angle when the insert is set in the cutter body.

APX3000



MULTI-FUNCTIONAL MILLING

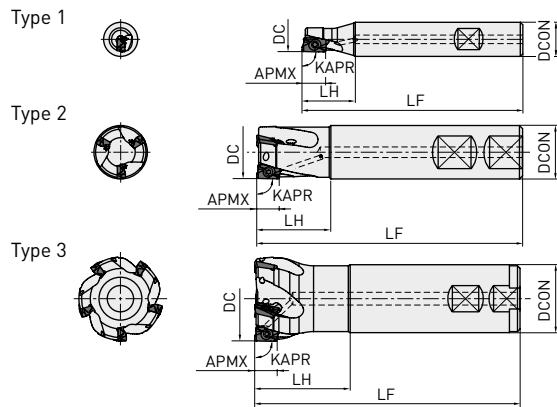

WELDON SHANK TYPE

Order Number	R	Teeth	DC	DCON	LF	LH	APMX	RMPX *2	Max. Spindle Speed [min ⁻¹]	Type								
											Clamp Screw	Wrench	Anti-seize Lubricant	Insert				
APX3000R121WA16SA	●	1	12	16	85	25	10	6.0°	10500	1	TPS25	TIP07F	MK1KS	AOMT 1236○○ PEER-○				
APX3000R141WA16SA	●	1	14	16	85	25	10	6.0°	9000	1								
APX3000R162WA16SA	●	2	16	16	85	25	10	11.3°	20900	2								
APX3000R182WA16SA	●	2	18	16	85	25	10	8.6°	19600	3								
APX3000R202WA20SA	●	2	20	20	100	30	10	6.9°	18500	2								
APX3000R203WA20SA	●	3	20	20	100	30	10	6.9°	18500	2								
APX3000R223WA20SA	●	3	22	20	115	30	10	5.7°	17600	3								
APX3000R252WA25SA	●	2	25	25	115	35	10	4.6°	16400	2								
APX3000R253WA25SA	●	3	25	25	115	35	10	4.6°	16400	2								
APX3000R254WA25SA	●	4	25	25	115	35	10	4.6°	16400	2								
APX3000R284WA25SA	●	4	28	25	115	35	10	3.8°	15500	3					TPS25-1	TIP07F	MK1KS	AOGT 1236○○ PEFR-GM
APX3000R304WA32SA	●	4	30	32	125	45	10	3.4°	14900	1								
APX3000R323WA32SA	●	3	32	32	125	45	10	3.1°	14400	2								
APX3000R324WA32SA	●	4	32	32	125	45	10	3.1°	14400	2								
APX3000R325WA32SA	●	5	32	32	125	45	10	3.1°	14400	2								
APX3000R403WA32SA	●	3	40	32	125	45	10	2.2°	12800	3								
APX3000R405WA32SA	●	5	40	32	125	45	10	2.2°	12800	3								
APX3000R406WA32SA	●	6	40	32	125	45	10	2.2°	12800	3								
APX3000R182WA16LA	●	2	18	16	120	25	10	8.6°	19600	3	TPS25	TIP07F	MK1KS	AOMT 1236○○ PEER-○				
APX3000R202WA20LA	●	2	20	20	150	60	10	6.9°	18500	2								
APX3000R222WA20LA	●	2	22	20	150	30	10	5.7°	17600	3	TPS25-1	TIP07F	MK1KS	AOGT 1236○○ PEFR-GM				
APX3000R253WA25LA	●	3	25	25	170	70	10	4.6°	16400	2								
APX3000R283WA25LA	●	3	28	25	170	35	10	3.8°	15500	3								
APX3000R353WA32LA	●	3	35	32	190	45	10	2.7°	13700	3								

- When using inserts with corner radius RE>2.4, machining of the holder is required as shown on page 12.
- The maximum allowable spindle speeds are set to ensure tool and insert stability.
- When using the tool at high spindle speeds, ensure that the tool and arbor are correctly balanced.

*1 Clamp Torque [N • m]: TPS25=1.0, TPS25-1=1.0

*2 RMPX: Max. Ramping Angle



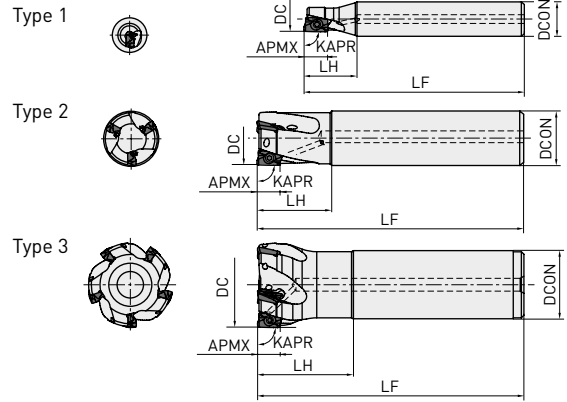

STRAIGHT SHANK TYPE

Order Number	R	Teeth	DC	DCON	LF	LH	APMX	RMPX *2	Max. Spindle Speed (min ⁻¹)	Type	Clamp Screw	Wrench	Anti-seize Lubricant	Insert
APX3000R121SA16SA	★	1	12	16	85	25	10	6.0°	10500	1				
APX3000R141SA16SA	★	1	14	16	85	25	10	6.0°	9000	1				
APX3000R162SA16SA	●	2	16	16	85	25	10	11.3°	20900	2				
APX3000R182SA16SA	★	2	18	16	85	25	10	8.6°	19600	3	TPS25			
APX3000R202SA20SA	★	2	20	20	100	30	10	6.9°	18500	2				
APX3000R203SA20SA	●	3	20	20	100	30	10	6.9°	18500	2				
APX3000R223SA20SA	●	3	22	20	115	30	10	5.7°	17600	3				
APX3000R252SA25SA	★	2	25	25	115	35	10	4.6°	16400	2				AOMT
APX3000R253SA25SA	★	3	25	25	115	35	10	4.6°	16400	2				1236○○
APX3000R254SA25SA	●	4	25	25	115	35	10	4.6°	16400	2				PEER-○
APX3000R284SA25SA	★	4	28	25	115	35	10	3.8°	15500	3		TIP07F	MK1KS	
APX3000R304SA32SA	★	4	30	32	125	45	10	3.4°	14900	2				AOGT
APX3000R323SA32SA	★	3	32	32	125	45	10	3.1°	14400	2				1236○○
APX3000R324SA32SA	★	4	32	32	125	45	10	3.1°	14400	2	TPS25-1			PEFR-GM
APX3000R325SA32SA	★	5	32	32	125	45	10	3.1°	14400	2				
APX3000R403SA32SA	★	3	40	32	125	45	10	2.2°	12800	3				
APX3000R405SA32SA	★	5	40	32	125	45	10	2.2°	12800	3				
APX3000R406SA32SA	★	6	40	32	125	45	10	2.2°	12800	3				
APX3000R507SA32SA	★	7	50	32	125	45	10	1.7°	11300	3				
APX3000R638SA32SA	★	8	63	32	125	45	10	1.3°	10000	3				
APX3000R182SA16LA	●	2	18	16	120	25	10	8.6°	19600	3				
APX3000R202SA20LA	●	2	20	20	150	60	10	6.9°	18500	2	TPS25			
APX3000R222SA20LA	●	2	22	20	150	30	10	5.7°	17600	3				
APX3000R252SA25LA	★	2	25	25	170	70	10	4.6°	16400	2				AOMT
APX3000R253SA25LA	★	3	25	25	170	70	10	4.6°	16400	2				1236○○
APX3000R282SA25LA	★	2	28	25	170	35	10	3.8°	15500	3	TPS25-1	TIP07F	MK1KS	PEER-○
APX3000R283SA25LA	★	3	28	25	170	35	10	3.8°	15500	3				AOGT
APX3000R322SA32LA	★	2	32	32	190	90	10	3.1°	14400	2				1236○○
APX3000R323SA32LA	★	3	32	32	190	90	10	3.1°	14400	2				PEFR-GM
APX3000R352SA32LA	★	2	35	32	190	45	10	2.7°	13700	3				
APX3000R353SA32LA	★	3	35	32	190	45	10	2.7°	13700	3				
APX3000R182SA16ELA	●	2	18	16	180	25	10	8.6°	19600	3				
APX3000R202SA20ELA	★	2	20	20	200	70	10	6.9°	18500	2	TPS25			
APX3000R222SA20ELA	★	2	22	20	200	30	10	5.7°	17600	3				
APX3000R252SA25ELA	★	2	25	25	220	80	10	4.6°	16400	2				AOMT
APX3000R253SA25ELA	★	3	25	25	220	80	10	4.6°	16400	2				1236○○
APX3000R282SA25ELA	★	2	28	25	220	35	10	3.8°	15500	3	TPS25-1	TIP07F	MK1KS	PEER-○
APX3000R283SA25ELA	★	3	28	25	220	35	10	3.8°	15500	3				AOGT
APX3000R322SA32ELA	★	2	32	32	260	100	10	3.1°	14400	2				1236○○
APX3000R323SA32ELA	★	3	32	32	260	100	10	3.1°	14400	2				PEFR-GM
APX3000R352SA32ELA	★	2	35	32	260	45	10	2.7°	13700	3				
APX3000R353SA32ELA	★	3	35	32	260	45	10	2.7°	13700	3				

1. When using inserts with corner radius RE>2.4, machining of the holder is required as shown on page 12.

2. The maximum allowable spindle speeds are set to ensure tool and insert stability.

3. When using the tool at high spindle speeds, ensure that the tool and arbor are correctly balanced.

*1 Clamp Torque (N • m): TPS25=1.0, TPS25-1=1.0

*2 RMPX: Max. Ramping Angle



APX3000



MULTI FUNCTIONAL MILLING

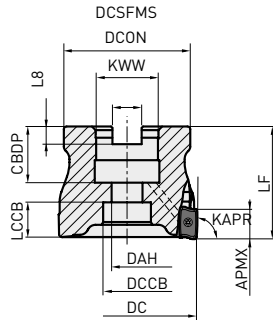

KAPR:90°
 GAMP:+7°-+21° T:+15°-+27°
 GAMF:+15°-+27° I:+7°-+21°

DC	Set Bolt	Geometry
Ø32, Ø40	HSC08030H	
Ø50, Ø63	10030H	
Ø80	12035H	
Ø100	16040H	

ARBOR TYPE

Order Number

Order Number	R	Teeth	DC	LF	DCON	CBDP	DAH	DCSFMS	KWW	L8	DCCB	LCCB	WT (kg) *2	APMX	RMPX *3	Max. Allowable Revolution (min ⁻¹)	Clamp Screw	Wrench	Anti-seize Lubricant	Insert
APX3000-032A05RA	●	5	32	40	16	18	9	30	8.4	5.6	14	10.22	0.2	10	3.1	14400				
APX3000-040A06RA	●	6	40	40	16	18	9	34	8.4	5.6	14	10.35	0.3	10	2.2	12800				AOMT
APX3000-050A07RA	●	7	50	40	22	20	11	45	10.4	6.3	17	12.35	0.4	10	1.7	11300				1236
APX3000-063A08RA	●	8	63	40	22	20	11	55	10.4	6.3	17	12.35	0.7	10	1.3	10000				PEER
APX3000-080A09RA	●	9	80	50	27	23	13	70	12.4	7	20	15.35	1.3	10	1.0	8800	TPS25-1	TIP07F	MK1KS	AOGT
APX3000-100A11RA	●	11	100	63	32	26	17	80	14.4	8	26	20.35	2.2	10	0.8	7800				1236
APX3000R08009CA	★	9	80	50	25.4	26	13	70	9.5	6	20	15.35	1.3	10	1.0	8800				PEFR-GM
APX3000R10011DA	★	11	100	63	31.75	32	17	80	12.7	8	26	20.35	2.2	10	0.8	7800				

1. When using inserts with corner radius RE>2.4, machining of the holder is required as shown page 12.

*1 Clamp Torque (N • m): TPS25-1=1.0

*2 WT: Tool Weight

*3 RMPX: Max. Ramping Angle

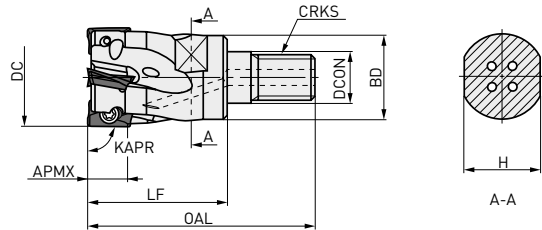
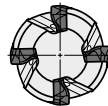
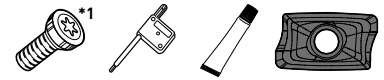

SCREW-IN TYPE

Order Number

Order Number	R	Teeth	DC	OAL	LF	DCON	BD	H	CRKS	APMX	RMPX *2	Clamp Screw	Wrench	Anti-seize Lubricant	Insert
APX3000R162M08A	●	2	16	48	30	8.5	13	10	M8	10	11.3°				AOMT
APX3000R203M10A	●	3	20	53	34	10.5	18	15	M10	10	6.9°	TPS25			1236
APX3000R254M12A	●	4	25	57	35	12.5	21	17	M12	10	4.6°		TIP07F	MK1KS	PEER-M/H
APX3000R325M16A	●	5	32	61	38	17	29	22	M16	10	3.1°	TPS25-1			AOGT
APX3000R406M16A	●	6	40	61	38	17	29	22	M16	10	2.2°				1236

1. When using inserts with corner radius RE>2.4, machining of the holder is required as shown on page 12.

2. For screw-in type arbors, refer to page 7-23.

*1 Clamp Torque (N • m): TPS25=1.0, TPS25-1=1.0

*2 RMPX: Max. Ramping Angle



RECOMMENDED CUTTING CONDITIONS

CUTTING SPEED

Material	Hardness	Grade	Breaker	ae			
				<0.25DC	0.25-0.5DC	0.5-0.75DC	DC (Slot)
P Mild Steel	<180HB	MP6120 VP15TF	M H	230(180-270)	220(170-260)	180(140-210)	180(140-210)
		MP6130 VP20RT	M H	200(150-240)	190(140-230)	150(110-180)	150(110-180)
	180-350HB	MP6120 VP15TF	M H	180(140-210)	170(130-200)	140(110-160)	140(110-160)
		MP6130 VP20RT	M H	150(110-180)	140(100-170)	110(80-130)	110(80-130)
M Stainless Steel	<270HB	MP7130 VP15TF	M H	180(140-210)	170(130-200)	140(110-160)	140(110-160)
K Gray Cast Iron	<350MPa	MC5020	H —	250(200-300)	240(190-290)	210(160-260)	140(110-160)
	<800MPa	MC5020	H —	130(100-150)	120(90-140)	100(80-120)	100(80-120)
N Aluminium Alloy	—	TF15	— GM	500(200-1000)	500(200-1000)	500(200-1000)	500(200-1000)
S Titanium Alloy	<350HB	MP9120 VP15TF	M H	50(40-70)	—	—	50(40-70)
		MP9130 VP20RT	M H	40(30-60)	—	—	40(30-60)
	—	MP9120 VP15TF	M H	40(30-60)	—	—	40(30-60)
		MP9130 VP20RT	M H	30(20-40)	—	—	30(20-40)
H Hardened Steel	40-55HRC	VP15TF	— H	90(70-100)	85(60-100)	70(50-80)	70(50-80)

DEPTH OF CUT / FEED PER TOOTH

Material	Hardness	ae	DC					
			Ø12-Ø16		Ø18-Ø25		Ø28-Ø100	
			ap	fz	ap	fz	ap	fz
P Mild Steel	<180HB	<0.25DC	<4	0.15	<5	0.25	<5	0.20
			4-7	0.10	5-7	0.15	5-7	0.15
			<2	0.15	7-8.5	0.15	7-8.5	0.10
		0.25-0.5DC	8.5-10	0.10	8.5-10	0.07	<3	0.20
			2-5	0.10	3-5.5	0.20	3-5.5	0.15
			5-8	0.15	5.5-8	0.15	5.5-8	0.10
	0.5-0.75DC	<4	0.10	8-10	0.10	8-10	0.07	
		4-10	0.10	<4	0.15	<3	0.10	
		<4	0.10	4-10	0.10	3-7	0.07	
	1.0DC	<3	0.10	<4	0.10	<3	0.10	
		4-7	0.07	4-7	0.07	3-5	0.07	
		<4	0.15	<5	0.20	<5	0.20	
M Stainless Steel	<270HB	<0.25DC	4-7	0.10	5-7	0.15	5-7	0.15
			<2	0.15	7-8.5	0.10	7-8.5	0.10
			8.5-10	0.07	8.5-10	0.07	<3	0.20
		0.25-0.5DC	2-5	0.10	3-5.5	0.15	3-5.5	0.15
			5-8	0.10	5.5-8	0.10	5.5-8	0.10
			8-10	0.07	8-10	0.07	8-10	0.07
	0.5-0.75DC	<4	0.10	<4	0.10	<3	0.10	
		4-10	0.07	4-10	0.07	3-7	0.07	
		<4	0.10	<4	0.10	<3	0.10	
	1.0DC	<3	0.10	4-7	0.07	3-5	0.07	
		4-7	0.07	4-7	0.07	3-5	0.07	
		<4	0.15	<5	0.25	<5	0.20	
K Gray Cast Iron	Tensile Strength <350MPa	<0.25DC	4-7	0.10	5-7	0.20	5-7	0.15
			<2	0.15	7-8.5	0.15	7-8.5	0.10
			8.5-10	0.10	8.5-10	0.10	8.5-10	0.07
		0.25-0.5DC	2-5	0.10	<3	0.25	<3	0.20
			3-5.5	0.20	3-5.5	0.20	3-5.5	0.15
			5.5-8	0.15	5.5-8	0.15	5.5-8	0.10
	0.5-0.75DC	<4	0.10	8-10	0.10	8-10	0.07	
		4-10	0.10	<4	0.15	<3	0.10	
		<4	0.10	4-10	0.10	3-7	0.07	
	1.0DC	<3	0.10	<4	0.10	<3	0.10	
		4-7	0.07	4-7	0.07	3-5	0.07	
		<4	0.10	<5	0.20	<5	0.20	
K Ductile, Cast Iron	Tensile Strength <800MPa	<0.25DC	4-7	0.07	5-7	0.15	5-7	0.15
			<2	0.10	7-8.5	0.10	7-8.5	0.10
			8.5-10	0.07	8.5-10	0.07	8.5-10	0.07
		0.25-0.5DC	2-5	0.07	<3	0.20	<3	0.20
			3-5.5	0.15	3-5.5	0.15	3-5.5	0.15
			5.5-8	0.10	5.5-8	0.10	5.5-8	0.10
	0.5-0.75DC	<4	0.07	8-10	0.07	8-10	0.07	
		4-10	0.07	<4	0.10	<3	0.10	
		<4	0.07	4-10	0.07	3-7	0.07	
	1.0DC	<3	0.07	<4	0.10	<3	0.10	
		4-7	0.07	4-7	0.07	3-5	0.07	
		<4	0.07	—	0.07	3-5	0.07	

Material	Hardness	ae	DC					
			Ø12-Ø16		Ø18-Ø25		Ø28-Ø100	
			ap	fz	ap	fz	ap	fz
N Aluminium Alloy	-	<0.25DC	<4	0.15	<4	0.25	<4	0.20
		0.25-0.5DC	4-7	0.10	4-7	0.15	4-7	0.10
		0.5-0.75DC	<4	0.15	<4	0.20	<4	0.20
		1.0DC	4-7	0.10	4-7	0.10	4-7	0.10
S Titanium Alloy	<350HB	<0.25DC	<4	0.15	<4	0.15	<4	0.10
		0.25-0.5DC	4-7	0.10	4-7	0.10	4-7	0.07
		0.5-0.75DC	<3	0.05	<3	0.05	<3	0.05
		1.0DC	<2	0.10	<2	0.05	<2	0.05
H Hardened Steel	40-55HRC	<0.25DC	<4	0.10	<5	0.15	<5	0.15
		0.25-0.5DC	4-7	0.07	5-7	0.10	5-7	0.10
		0.5-0.75DC	<2	0.10	<3	0.15	<3	0.15
		1.0DC	2-5	0.07	3-5.5	0.10	—	—

- These cutting conditions are a guide to the standard shank type and the arbor Type. Please make adjustments according to the machining conditions.
- Vibration is liable to occur in certain cases. Please reduce the depth of cut and / or reduce cutting conditions in the following cases.
 - When using the long shank type and extra long shank Type
 - When using long tool overhang with the standard or arbor Type
 - When the application has poor clamping rigidity or when using a low rigidity machine.
- In case of coarse and fine pitch cutters, the coarse pitch type is recommended to prevent vibration.
- For heavy interrupted and unstable cutting, the H breaker is first recommendation.

RAMPING

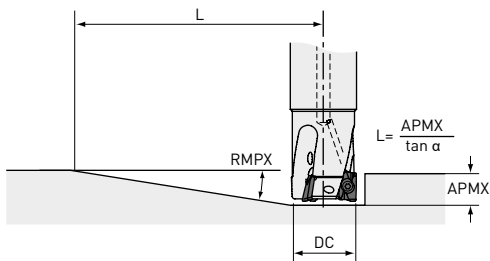

HELICAL CUTTING

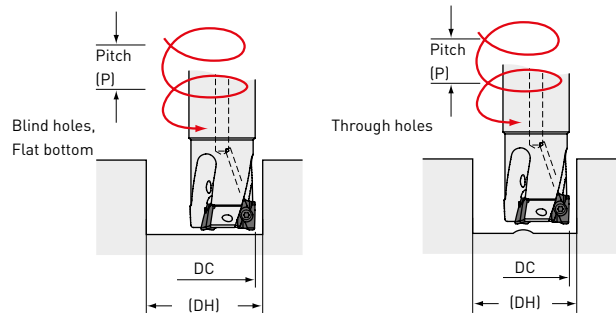

Refer to the table below for cutting conditions. For feed per tooth and cutting speed, follow the cutting conditions for slot milling.

Cutting Edge Diameter DC(mm)	Ramping		Helical Cutting (Blind Hole, Flat Bottom)			Helical Cutting (Through Hole)		
	Maximum Ramping Angle RMPX	Minimum Distance *1 L(mm)	Maximum Hole Diameter *2 DH max.(mm)	Maximum Pitch P max.(mm)	Minimum Hole Diameter DH min.(mm)	Maximum Pitch P max.(mm)	Minimum Hole Diameter DH min.(mm)	Maximum Pitch P max.(mm)
12	6.0°	95	22	2.5	20.5	2	14	0.5
14	6.0°	95	26	2.5	24.5	2	18	1
16	11.3°	50	30	9	28	7	21	2
18	8.6°	66	34	5	32	4.5	25	2
20	6.9°	83	38	5	36	4.5	29	2
22	5.7°	100	42	5	40	4.5	33	2
25	4.6°	124	48	6	46	5	39	3
28	3.8°	151	54	4.5	52	4	45	2
30	3.4°	168	58	4.5	56	4	49	2
32	3.1°	185	62	4.5	60	4	53	2
35	2.7°	212	68	4	66	3.5	59	2
40	2.2°	260	78	4	76	3.5	69	2
50	1.7°	337	98	2	96	2	89	2
63	1.3°	441	124	2	122	2	115	2
80	1.0°	573	158	2	156	2	149	2
100	0.8°	716	198	1	196	1	189	1

- When machining highly ductile materials with ramping angles above, chips could be continuous. In this case, decrease the ramping angle or feed per tooth.
- *1 $L = 10 / \tan \alpha$. Cutters' moving distance until depth of cut reaches 10mm at a maximum ramping angle.
- *2 In case corner radius of 0.8mm. Other than that, find with the below formula.

$$[(\text{cutting edge diameter DC}) - (\text{corner radius}) - 0.2] \times 2$$

APX3000



DEEP SHOULDER MILLING



LONG CUTTING EDGE



Type 1

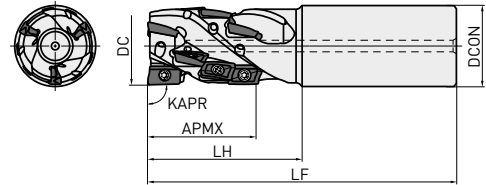

SHANK TYPE

Order Number

Order Number	R	Flutes	CICT	DC	DCON	LF	LH	APMX	Type	Clamp Screw	Wrench	Anti-seize Lubricant	Insert
APX3KR2004SN20S028A	★	1	4	20	20	125	45	28	1	TPS25			
APX3KR2506SA25S028A	●	2	6	25	25	125	45	28	1				
APX3KR2508SA25M037A	●	2	8	25	25	130	50	37	1				
APX3KR3208SA32S037A	★	2	8	32	32	130	50	37	1				
APX3KR3210SA32M046A	★	2	10	32	32	140	60	46	1	TPS25-1	TIP07F	MK1KS	AO-T1236 PEER
APX3KR3212SA32S037A	★	3	12	32	32	130	50	37	1				
APX3KR3215SA32M046A	★	3	15	32	32	140	60	46	1				
APX3KR4015SA42S046A	★	3	15	40	42	140	60	46	1				
APX3KR4018SA42M055A	★	3	18	40	42	150	70	55	1				

- When using inserts with corner radius RE>3.2, machining of the holder is required as shown on page 12.
 - Only corner radius Re 0.4mm and 0.8mm can be used for the peripheral cutting edges except the bottom cutting edge (the end cutting edge).
 - When using the tool at high spindle speeds, ensure that the tool and arbor are correctly balanced.
- * Clamp Torque (N • m): TPS43=3.5



APX3000



DEEP SHOULDER MILLING



LONG CUTTING EDGE

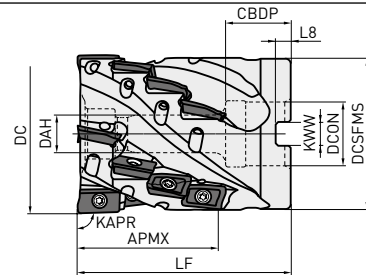

DC	Set Bolt	Geometry
Ø40	HSC08040	
Ø50	HSC10045	

SHELL TYPE

Order Number	R	Flutes	CICT	DC	LF	DCON	CBDP	DAH	DCSFMS	KWW	L8	APMX	Clamp Screw	Wrench	Anti-seize Lubricant	Insert
APX3K-040A16A037RA	●	4	16	40	50	16	18	9	38.5	8.4	5.6	37	TPS43	TIP15W	MK1KS	A0T1236
APX3K-050A20A046RA	●	4	20	50	60	22	20	11	48.4	10.4	6.3	46				PEER

- When using inserts with corner radius RE>3.2, machining of the holder is required as shown on page 12.
- Only corner radius Re 0.4mm and 0.8mm can be used for the peripheral cutting edges expect the bottom cutting edge (the end cutting edge).
- When using the tool at high spindle speeds, ensure that the tool and arbor are correctly balanced.
- In case of internal coolant supply, please use a face mill arbor with through coolant channels.
Regular center-thru or side-thru arbors can't be used.

* Clamp Torque (N • m): TPS43=3.5



APX3000

RECOMMENDED CUTTING CONDITIONS

CUTTING SPEED

Material	Hardness	Grade	Breaker	ae					
				<0.25DC	0.25-0.75DC	1.0DC			
				Vc					
P Mild Steel	<180HB	MP6120	VP15TF	M	H	180(140-220)	150(110-180)	120(100-140)	
		MP6130	VP20RT	M	H	160(120-200)	130(100-160)	100(80-120)	
	Carbon Steel Alloy Steel	180-350HB	MP6120	VP15TF	M	H	150(100-200)	120(90-150)	100(80-120)
			MP6130	VP20RT	M	H	130(90-170)	90(70-110)	80(60-100)
			MP6120	VP15TF	M	H	120(80-160)	100(70-130)	90(50-120)
			MP6130	VP20RT	M	H	100(70-130)	90(60-120)	70(50-100)
M Stainless Steel	<270HB	MP7130	—	M	—	150(120-180)	120(100-140)	100(80-120)	
K Gray Cast Iron	<350MPa	MC5020	—	H	—	200(150-250)	180(150-210)	—	
		VP15TF	—	M	H	180(120-240)	150(100-200)	100(60-140)	
Ductile, Cast Iron	<800MPa	VP15TF	—	M	H	160(120-200)	140(100-180)	80(60-100)	
N Aluminium Alloy	-	TF15	MP9120	GM	M	400(200-800)	400(200-800)	400(200-800)	
S Titanium Alloy	<350HB	MP9130	—	M	—	40(30-60)	—	40(30-60)	
		MP9120	—	M	—	50(40-70)	—	50(40-70)	
	Heat-resistant Alloy	-	MP9120	VP15TF	M	H	40(30-60)	—	40(30-60)
			MP9130	VP20RT	M	H	30(20-40)	—	30(20-40)

DEPTH OF CUT / FEED PER TOOTH

Material	Hardness	ae	DC						
			Ø20		Ø25		Ø32-Ø50		
			ap	fz	ap	fz	ap	fz	
P Mild Steel	<180HB	<0.25DC	<28	0.15	<37	0.17	<55	0.2	
		0.25-0.75DC	<28	0.12	<37	0.15	<55	0.17	
		1.0 DC	<18	0.08	<18	0.08	<18	0.08	
	Carbon Steel Alloy Steel	180-280HB	<0.25DC	<28	0.12	<37	0.15	<55	0.17
			0.25-0.75DC	<28	0.1	<37	0.12	<55	0.15
			1.0 DC	<18	0.08	<18	0.08	<18	0.08
Tool Alloy Steel	<350HB (Annealing)	<0.25DC	<28	0.12	<37	0.15	<55	0.17	
		0.25-0.75DC	<28	0.1	<37	0.12	<55	0.15	
		1.0 DC	<18	0.08	<18	0.08	<18	0.08	
Pre-hardened Steel	35-45HRC	<0.25DC	<28	0.12	<37	0.15	<55	0.17	
		0.25-0.75DC	<28	0.1	<37	0.12	<55	0.15	
		1.0 DC	<18	0.08	<18	0.08	<18	0.08	
M Ferritic and Martensitic Stainless Steel	—	<0.25DC	<28	0.12	<37	0.15	<55	0.17	
		0.25-0.75DC	<28	0.1	<37	0.12	<55	0.15	
		1.0 DC	<18	0.08	<18	0.08	<18	0.08	
	Duplex Stainless Steel	<280HB	<0.25DC	<28	0.12	<37	0.15	<55	0.17
			0.25-0.75DC	<28	0.1	<37	0.12	<55	0.15
			1.0 DC	<18	0.08	<18	0.08	<18	0.08
Precipitation Hardening Stainless Steel	<450HB	<0.25DC	<28	0.12	<37	0.15	<55	0.17	
		0.25-0.75DC	<28	0.1	<37	0.12	<55	0.15	
		1.0 DC	<18	0.08	<18	0.08	<18	0.08	
K Gray Cast Iron	Tensile Strength <350MPa	<0.25DC	<28	0.15	<37	0.17	<55	0.2	
		0.25-0.75DC	<28	0.12	<37	0.15	<55	0.17	
		1.0 DC	<18	0.1	<18	0.1	<18	0.1	
Ductile Cast Iron	Tensile Strength <800MPa	<0.25DC	<28	0.12	<37	0.15	<55	0.17	
		0.25-0.75DC	<28	0.1	<37	0.12	<55	0.15	
		1.0 DC	<18	0.08	<18	0.08	<18	0.08	
N Aluminium Alloy	—	<0.25DC	<28	0.15	<37	0.17	<55	0.2	
		0.25-0.75DC	—	—	<9	0.17	<9	0.2	
		1.0 DC	—	—	<9	0.17	<9	0.2	
S Titanium Alloy	<350HB	<0.25DC	<28	0.1	<37	0.1	<55	0.1	
		0.25-0.75DC	—	—	—	—	—	—	
		1.0 DC	<18	0.06	<18	0.06	<18	0.06	
	Heat-resistant Alloy	—	<0.25DC	<28	0.08	<37	0.08	<55	0.08
			0.25-0.75DC	—	—	—	—	—	—
			1.0 DC	<18	0.05	<18	0.05	<18	0.05

1. The above cutting conditions are determined based on high rigidity machine and work materials, where no vibration occurred. Please adjust processing conditions if the vibration is generated.

INSERTS

P Steel	● ✳	● ✳	Cutting Conditions (Guide):	
M Stainless Steel	● ✳	● ✳	●: Stable Cutting	●: General Cutting ✳: Unstable Cutting
K Cast Iron	● ✳	● ✳		
N Non-ferrous Metal	● ✳	● ✳	Honing:	
S Heat-resistant Alloy, Titanium Alloy	● ✳	● ✳	E: Round	
H Hardened Steel	● ✳	● ✳	F: Sharp	
			T: Chamfer	

Order Number	Class	Honing	MC5020	MP6120	MP6130	MP7130	MP9120	MP9130	VP15TF	VP20RT	TF15	L	LE	W1	S	BS	RE	Geometry
AOMT123602PEER-M	M	E	●	●	●	●	●	●	●	●	●	12	10	6.6	3.6	1.8	0.2	
AOMT123604PEER-M	M	E	●	●	●	●	●	●	●	●	12	10	6.6	3.6	1.6	0.4		
AOMT123608PEER-M	M	E	●	●	●	●	●	●	●	●	12	10	6.6	3.6	1.2	0.8		
AOMT123610PEER-M	M	E	●	●	●	●	●	●	●	●	12	10	6.6	3.6	1.0	1.0		
AOMT123612PEER-M	M	E	●	●	●	●	●	●	●	●	12	10	6.6	3.6	0.8	1.2		
AOMT123616PEER-M	M	E	●	●	●	●	●	●	●	●	12	10	6.6	3.6	0.4	1.6		
AOMT123620PEER-M	M	E	●	●	●	●	●	●	●	●	12	10	6.6	3.6	0.4	2.0		
AOMT123624PEER-M	M	E	●	●	●	●	●	●	●	●	12	10	6.6	3.6	0.4	2.4		
AOMT123630PEER-M	M	E	●	●	●	●	●	●	●	●	12	10	6.6	3.6	0.4	3.0		
AOMT123632PEER-M	M	E	●	●	●	●	●	●	●	●	12	10	6.6	3.6	0.4	3.2		
AOMT123604PEER-H	M	E	●	●	●	●	●	●	●	●	12	10	6.6	3.6	1.6	0.4		
AOMT123608PEER-H	M	E	●	●	●	●	●	●	●	●	12	10	6.6	3.6	1.2	0.8		
AOMT123616PEER-H	M	E	●	●	●	●	●	●	●	●	12	10	6.6	3.6	0.4	1.6		
AOGT123602PEFR-GM	G	F							●			12	10	6.6	3.6	1.8	0.2	
AOGT123604PEFR-GM	G	F							●			12	10	6.6	3.6	1.6	0.4	
AOGT123608PEFR-GM	G	F							●			12	10	6.6	3.6	1.2	0.8	

NOTE ON USE OF INSERTS WITH LARGE CORNER RADII

When using inserts with corner radius $RE > R_{2.4}$, please machine the holder with a radius form as shown on the right.

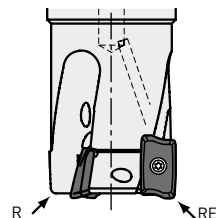

RE (mm)	R (mm)
2.4	1.9
3.0	2.5
3.2	2.7

R: Holder end radius
RE: Insert corner radius

APX4000



MULTI FUNCTIONAL MILLING



Type 1

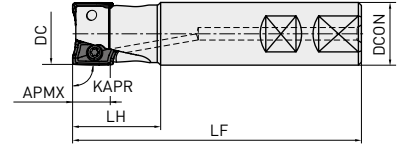

Type 2

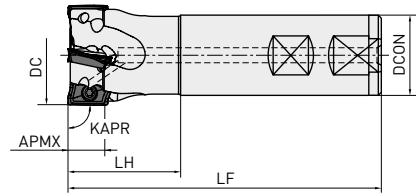
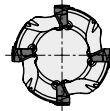

WELDON SHANK TYPE

	Order Number	R	Teeth	DC	DCON	LF	LH	APMX (mm)	RMPX *2	Max. Spindle Speed (min ⁻¹)	Type	Clamp Screw *1	Wrench	Anti-seize Lubricant	Insert
STANDARD	APX4000R252WA25SA	●	2	25	25	115	35	15	11°	18900	1	TPS4	TIP15W	MK1KS	AOMT 1848 PEER-M/H
	APX4000R323WA32SA	●	3	32	32	125	45	15	7°	16300	1				
	APX4000R403WA32SA	●	3	40	32	125	45	15	6°	14200	2	TPS43	TIP15W	MK1KS	AOMT 1848 PEER-M/H
	APX4000R404WA32SA	●	4	40	32	125	45	15	6°	14200	2				
LONG	APX4000R252WA25LA	●	2	25	25	170	35	15	11°	18900	1	TPS4	TIP15W	MK1KS	AOMT 1848 PEER-M/H
	APX4000R282WA25LA	●	2	28	25	170	35	15	9°	17700	2				
	APX4000R323WA32LA	●	3	32	32	190	45	15	7°	16300	1	TPS43	TIP15W	MK1KS	AOMT 1848 PEER-M/H
	APX4000R353WA32LA	●	3	35	32	190	45	15	6°	15400	2				
EXTRA LONG	APX4000R252WA25ELA	●	2	25	25	220	80	15	11°	18900	1	TPS4	TIP15W	MK1KS	AOMT 1848 PEER-M/H
	APX4000R282WA25ELA	●	2	28	25	220	35	15	9°	17700	2				
	APX4000R323WA32ELA	●	3	32	32	260	100	15	7°	16300	1				

1. When using inserts with corner radius RE>3.2, machining of the holder is required as shown on page 21.
2. The maximum allowable spindle speeds are set to ensure tool and insert stability.
3. When using the tool at high spindle speeds, ensure that the tool and arbor are correctly balanced.

*1 Clamp Torque (N • m): TPS4=3.5, TPS43=3.5

*2 RMPX: Max. Ramping Angle



APX4000



MULTI FUNCTIONAL MILLING



Type 1

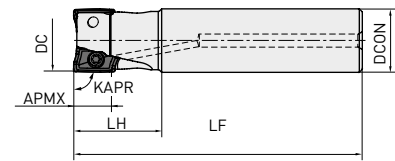

Type 2

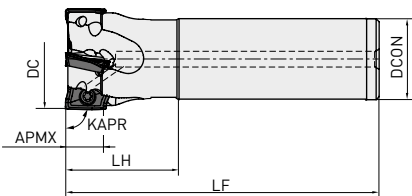
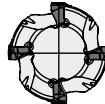

SHANK TYPE

Order Number	R	Teeth	DC	DCON	LF	LH	APMX	RMPX *2	Max. Spindle Speed (min ⁻¹)	Type					
											Clamp Screw	Wrench	Anti-seize Lubricant	Insert	
STANDARD	APX4000R252SA25SA	★	2	25	25	115	35	15	11°	18900	1				
	APX4000R322SA32SA	★	2	32	32	125	45	15	7°	16300	1	TPS4			
	APX4000R323SA32SA	★	3	32	32	125	45	15	7°	16300	1				
	APX4000R403SA32SA	★	3	40	32	125	45	15	6°	14200	2				
	APX4000R404SA32SA	★	4	40	32	125	45	15	6°	14200	2		TIP15W	MK1KS	AOMT 1848 PEER-M/H
	APX4000R504SA32SA	★	4	50	32	125	45	15	4°	12400	2				
	APX4000R505SA32SA	★	5	50	32	125	45	15	4°	12400	2	TPS43			
	APX4000R634SA32SA	★	4	63	32	125	45	15	3°	10800	2				
APX4000R636SA32SA	★	6	63	32	125	45	15	3°	10800	2					
LONG	APX4000R252SA25LA	★	2	25	25	170	35	15	11°	18900	1				
	APX4000R282SA25LA	★	2	28	25	170	35	15	9°	17700	2				
	APX4000R322SA32LA	★	2	32	32	190	45	15	7°	16300	1	TPS4			
	APX4000R323SA32LA	★	3	32	32	190	45	15	7°	16300	1				
	APX4000R352SA32LA	★	2	35	32	190	45	15	6°	15400	2		TIP15W	MK1KS	AOMT 1848 PEER-M/H
	APX4000R353SA32LA	★	3	35	32	190	45	15	6°	15400	2				
	APX4000R402SA32LA	★	2	40	32	190	45	15	6°	14200	2				
	APX4000R403SA32LA	★	3	40	32	190	45	15	6°	14200	2	TPS43			
APX4000R404SA32LA	★	4	40	32	190	45	15	6°	14200	2					
EXTRA LONG	APX4000R252SA25ELA	★	2	25	25	220	80	15	11°	18900	1				
	APX4000R282SA25ELA	★	2	28	25	220	35	15	9°	17700	2				
	APX4000R322SA32ELA	★	2	32	32	260	100	15	7°	16300	1	TPS4			
	APX4000R323SA32ELA	★	3	32	32	260	100	15	7°	16300	1				
	APX4000R352SA32ELA	★	2	35	32	260	45	15	6°	15400	2		TIP15W	MK1KS	AOMT 1848 PEER-M/H
	APX4000R353SA32ELA	★	3	35	32	260	45	15	6°	15400	2				
	APX4000R402SA32ELA	★	2	40	32	260	45	15	6°	14200	2				
	APX4000R403SA32ELA	★	3	40	32	260	45	15	6°	14200	2	TPS43			
APX4000R404SA32ELA	★	4	40	32	260	45	15	6°	14200	2					

1. When using inserts with corner radius RE>3.2, machining of the holder is required as shown page 21.

2. The maximum allowable revolutions are set to ensure tool and insert stability.

3. When using the tool at high spindle speeds, ensure that the tool and arbor are correctly balanced.

*1 Clamp Torque (N • m): TPS4=3.5, TPS43=3.5

*2 RMPX: Max. Ramping Angle



APX4000



MULTI FUNCTIONAL MILLING



Type 1

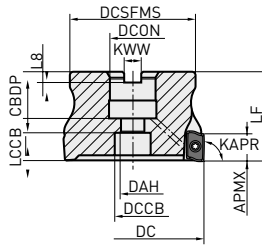

Type 2

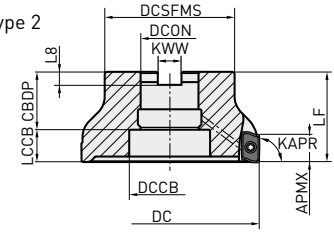

DC	Set Bolt	Geometry
Ø40	HSC08030H	①
Ø50, Ø63	10030H	
Ø80	12035H	②
Ø100	16040H	
Ø125	MBA20040H	
Ø160	24045H	

ARBOR TYPE

GAMP: +15°-+22° T: +21°-+28°
 GAMF: +21°-+28° I: +15°-+22°

Order Number

Order Number	R	Teeth	DC	LF	DCON	CBDP	DAH	DCSFMS	KWW	L8	DCCB	LCCB	WT (kg) *2	APMX	RMPX *3	Max. Allowable Revolution (min ⁻¹)	Type	Clamp Screw	Wrench	Anti-seize Lubricant	Insert
APX4000-040A04RA	●	4	40	40	16	18	9	34	8.4	5.6	14	10.08	0.2	15	6°	14200	1				
APX4000-050A05RA	●	5	50	40	22	20	11	45	10.4	6.3	17	12.26	0.3	15	4°	12400	1				
APX4000-063A06RA	●	6	63	40	22	20	11	50	10.4	6.3	17	12.35	0.5	15	3°	10800	1	TPS43	TIP15W	MK1KS	AOMT 1848 PEER-M/H
APX4000-080A07RA	●	7	80	50	27	23	13	60	12.4	7	20	15.35	1.2	15	2°	9300	1				
APX4000-100A08RA	●	8	100	50	32	25	17	70	14.4	8	27	17.35	2.1	15	1.5°	8100	1				
APX4000-125A09RA	●	9	125	63	40	40	56	90	16.4	9	-	22.35	3.3	15	1°	7100	2				
APX4000-160A10RA	●	10	160	63	40	40	72	100	16.4	9	-	22.35	4.8	15	1°	6100	2				

- When using inserts with corner radius RE>3.2, machining of the holder is required as shown on page 21.
- The maximum allowable revolutions are set to ensure tool and insert stability.
- When using the tool at high spindle speeds, ensure that the tool and arbor are correctly balanced.

*1 Clamp Torque (N • m): TPS43=3.5

*2 WT: Tool Weight

*3 RMPX: Max. Ramping Angle

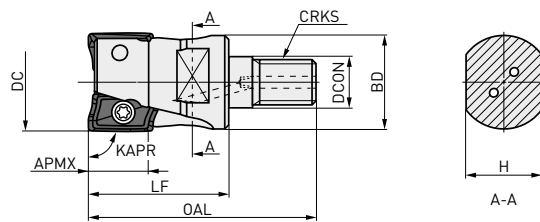

Right hand tool holder only.

SCREW-IN TYPE

Order Number

Order Number	R	Coolant Hole	Teeth	DC	DCON	BD	OAL	LF	H	CRKS	WT (kg) *2	APMX	Clamp Screw	Wrench	Anti-seize Lubricant	Insert
APX4000R252M12A35	●	○	2	25	12.5	23.5	57	35	19	M12	0.2	15	TPS4			AOMT 1848 PEER-M/H
APX4000R282M12A35	●	○	2	28	12.5	23.5	57	35	19	M12	0.2	15				
APX4000R322M16A40	★	○	2	32	17	28.5	63	40	24	M16	0.3	15				
APX4000R323M16A40	●	○	3	32	17	28.5	63	40	24	M16	0.3	15	TIP15W	MK1KS		
APX4000R352M16A40	★	○	2	35	17	28.5	63	40	24	M16	0.3	15				
APX4000R353M16A40	★	○	3	35	17	28.5	63	40	24	M16	0.3	15	TPS43			
APX4000R403M16A40	★	○	3	40	17	28.5	63	40	24	M16	0.3	15				
APX4000R404M16A40	●	○	4	40	17	28.5	63	40	24	M16	0.3	15				

- When using inserts with corner radius RE>3.2, machining of the holder is required as shown on page 21.
- For screw-in type arbors, refer to page 7-23.

*1 Clamp Torque (N • m): TPS4=3.5, TPS43=3.5

*2 WT: Tool Weight



RECOMMENDED CUTTING CONDITIONS

CUTTING SPEED

Material	Hardness	Grade	Breaker	ae					
				<0.25DC	0.25-0.5DC	0.5-0.75DC	DC (Slot)		
P Mild Steel	<180HB	MP6120	VP15TF	M	H	230(180-270)	220(170-260)	180(140-210)	180(140-210)
		MP6130	VP20RT	M	H	200(150-240)	190(140-230)	150(110-180)	150(110-180)
	180-350HB	MP6120	VP15TF	M	H	180(140-210)	170(130-200)	140(110-160)	140(110-160)
		MP6130	VP20RT	M	H	150(110-180)	140(100-170)	110(80-130)	110(80-130)
M Stainless Steel	<270HB	MP7130	VP15TF	M	H	180(140-210)	170(130-200)	140(110-160)	140(110-160)
K Gray Cast Iron	<350MPa	MC5020	—	H	—	250(200-300)	240(190-290)	210(160-260)	140(110-160)
	<800MPa	MC5020	—	H	—	130(100-150)	120(90-140)	100(80-120)	100(80-120)
S Titanium Alloy	<350HB	MP9120	VP15TF	H	M	50(40-70)	—	—	50(40-70)
		MP9130	VP20RT	H	M	40(30-60)	—	—	40(30-60)
		MP9120	VP15TF	H	M	40(30-60)	—	—	40(30-60)
Heat-resistant Alloy	—	MP9130	VP20RT	H	M	30(20-40)	—	—	30(20-40)
		VP15TF	—	H	—	90(70-100)	85(60-100)	70(50-80)	70(50-80)

DEPTH OF CUT / FEED PER TOOTH

Material	Hardness	ae	ap	fz		
				DC		
				Ø25-Ø40	Ø50-Ø80	Ø100-Ø160
P Mild Steel	<180HB	<0.5DC	<5	0.30	0.30	0.25
			5 - 7.5	0.25	0.25	0.20
			7.5 - 10	0.20	0.20	0.15
			10 - 12.5	0.15	0.15	0.10
			12.5 - 15	0.10	0.10	0.07
			<5	0.20	0.20	0.15
	180-350HB	0.5-0.75DC	5 - 10	0.15	0.15	0.10
			10 - 15	0.10	0.10	0.07
			<5	0.15	0.15	0.15
			5 - 7.5	0.10	0.10	0.10
			7.5 - 10	0.07	0.07	0.07
			1.0DC	0.10	0.10	0.10
M Stainless Steel	<270HB	<0.5DC	<5	0.30	0.25	0.25
			5 - 7.5	0.25	0.20	0.20
			7.5 - 10	0.20	0.15	0.15
			10 - 12.5	0.15	0.10	0.10
			12.5 - 15	0.10	0.07	0.07
			<5	0.20	0.15	0.15
		0.5-0.75DC	5 - 10	0.15	0.10	0.10
			10 - 15	0.10	0.07	0.07
			<5	0.15	0.15	0.15
			5 - 7.5	0.10	0.10	0.10
			7.5 - 10	0.07	0.07	0.07
			1.0DC	0.10	0.10	0.10
K Gray Cast Iron	Tensile Strength <350MPa	<0.5DC	<5	0.30	0.30	0.25
			5 - 7.5	0.25	0.25	0.20
			7.5 - 10	0.20	0.20	0.15
			10 - 12.5	0.15	0.15	0.10
			12.5 - 15	0.10	0.10	0.07
			<5	0.20	0.20	0.15
		0.5-0.75DC	5 - 10	0.15	0.15	0.10
			10 - 15	0.10	0.10	0.07
			<5	0.15	0.15	0.15
			5 - 7.5	0.10	0.10	0.10
			7.5 - 10	0.07	0.07	0.07
			1.0DC	0.10	0.10	0.10
K Ductile, Cast Iron	Tensile Strength <800MPa	<0.5DC	<5	0.25	0.25	0.25
			5 - 7.5	0.20	0.20	0.20
			7.5 - 10	0.15	0.15	0.15
			10 - 12.5	0.10	0.10	0.10
			12.5 - 15	0.07	0.07	0.07
			<5	0.20	0.20	0.15
		0.5-0.75DC	5 - 10	0.15	0.15	0.10
			10 - 15	0.10	0.10	0.07
			<5	0.15	0.15	0.15
			5 - 7.5	0.10	0.10	0.10
			7.5 - 10	0.07	0.07	0.07
			1.0DC	0.10	0.10	0.10

Material	Hardness	ae	ap	fz			
				DC			
				Ø25-Ø40	Ø50-Ø80	Ø100-Ø160	
S	Titanium Alloy	<350HB	<5	0.15	0.10	0.10	
			5-7.5	0.10	0.05	0.05	
			7.5-10	0.05	—	—	
			1.0DC	0.05	0.05	0.05	
Heat-resistant Alloy	—	<0.25DC	0.10	0.05	0.05		
		1.0DC	0.05	0.05	0.05		
H	Hardened Steel	40-55HRC	<5	0.15	0.15	0.15	
			<0.25DC	0.10	0.10	0.10	
			7.5-10	0.07	0.07	0.07	
			<5	0.10	0.10	0.10	
			0.25-0.5DC	0.07	0.07	0.07	
			5-7.5	0.07	0.07	0.07	
			0.5-0.75DC	<5	0.07	0.07	0.07
			1.0DC	<5	0.07	0.07	0.07

- These cutting conditions are a guide to the standard shank type and the arbor Type. Please make adjustments according to the machining conditions.
- Vibration is liable to occur in certain cases. Please reduce the depth of cut and / or reduce cutting conditions in the following cases.
 - When using the long shank type and extra long shank Type
 - When using long tool overhang with the standard or arbor Type
 - When the application has poor clamping rigidity or when using a low rigidity machine.
- In case of coarse and fine pitch cutters, the coarse pitch type is recommended to prevent vibration.
- For heavy interrupted and unstable cutting, the H breaker is first recommendation.

RAMPING

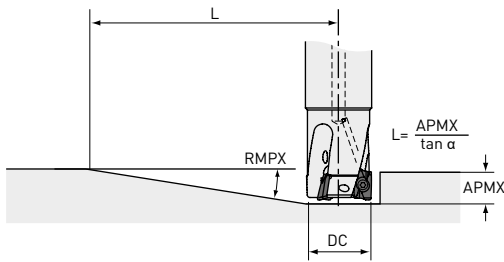

HELICAL CUTTING

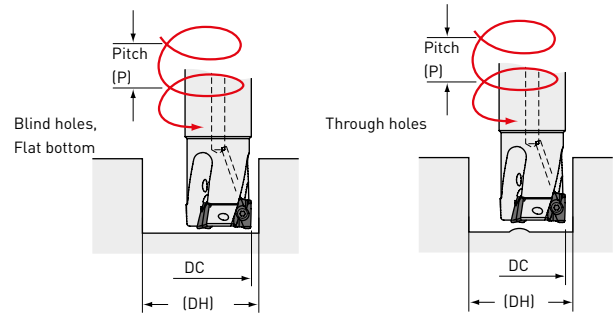

Refer to the table below for cutting conditions. For feed per tooth and cutting speed, follow the cutting conditions for slot milling.

Cutting Edge Diameter DC(mm)	Ramping		Helical Cutting (Blind Hole, Flat Bottom)			Helical Cutting (Through Hole)		
	Maximum Ramping Angle RMPX	Minimum Distance *1 L(mm)	Maximum Hole Diameter *2 DH max.(mm)	Maximum Pitch P max.(mm)	Minimum Hole Diameter DH min.(mm)	Maximum Pitch P max.(mm)	Minimum Hole Diameter DH min.(mm)	Maximum Pitch P max.(mm)
25	11°	85	48	14	45	12	32	4
28	9°	105	54	12	51	11	38	4
32	7°	135	62	11	59	10	46	5
35	6°	158	68	10	65	9	52	5
40	6°	158	78	12	75	11	62	7
50	4°	238	98	10	95	9	82	7
63	3°	318	124	10	121	9	108	7
80	2°	477	158	8	155	8	142	6
100	1.5°	636	198	8	195	7	182	6
125	1°	954	248	6	245	6	232	5
160	1°	954	318	8	315	8	302	7

- When machining highly ductile materials with ramping angles above, chips could be continuous. In this case, decrease the ramping angle or feed per tooth.
 - *1 $L = 15 / \tan \alpha$. Cutters' moving distance until depth of cut reaches 15mm at a maximum ramping angle.
 - *2 In case corner radius of 0.8mm. Other than that, find with the below formula. $\{(\text{cutting edge diameter DC}) - (\text{corner radius}) - 0.2\} \times 2$

APX4000



DEEP SHOULDER MILLING



LONG CUTTING EDGE



Type 1

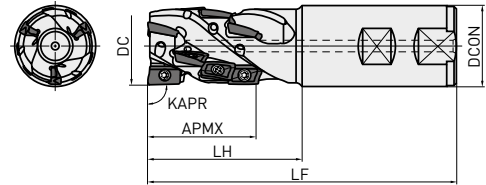

Type 2

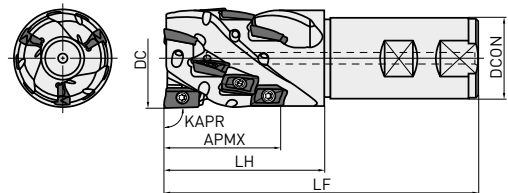

SHANK TYPE

Order Number

Order Number	R	Flutes	Total	DC	DCON	LF	LH	APMX	Type				
										Clamp Screw	Wrench	Anti-seize Lubricant	Insert
APX4KR4008WA40S056A	●	2	8	40	40	150	80	56	1				
APX4KR4012WA40S056A	●	3	12	40	40	150	80	56	1	TPS43	TIP15W	MK1KS	A0MT1848 ○PEER○
APX4KR5012WA40S056A	●	3	12	50	40	150	80	56	2				
APX4KR5018WA40M084A	●	3	18	50	40	180	110	84	2				

- When using inserts with corner radius RE>3.2, machining of the holder is required as shown on page 21.
- Only corner radius Re 0.4mm and 0.8mm can be used for the peripheral cutting edges except the bottom cutting edge (the end cutting edge).
- When using the tool at high spindle speeds, ensure that the tool and arbor are correctly balanced.

* Clamp Torque (N • m): TPS43=3.5



APX4000



DEEP SHOULDER MILLING

P M K S

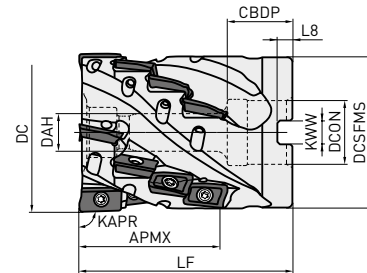

DC	Set Bolt	Geometry
Ø50	HSC10050	
Ø63	HSC12070	

SHELL TYPE

Order Number

	R	Flutes Total	DC	LF	DCON	CBDP	DAH	DCSFMS	KWW	L8	APMX	Clamp Screw	Wrench	Anti-seize Lubricant	Insert
APX4K-050A09A042RA	●	3 9	50	65	22	22	11	48	10.4	6.3	42	TPS43	TIP15W	MK1KS	AOMT1848
APX4K-063A16A056RA	●	4 16	63	85	27	28	13	60.7	12.4	7	56				○PEER○

- When using inserts with corner radius $RE > 3.2$, machining of the holder is required as shown on page 21.
 - Only corner radius Re 0.4mm and 0.8mm can be used for the peripheral cutting edges except the bottom cutting edge (the end cutting edge).
 - When using the tool at high spindle speeds, ensure that the tool and arbor are correctly balanced.
 - In case of internal coolant supply, please use a face mill arbor with through coolant channels. Regular center-thru or side-thru arbors can't be used.
- * Clamp Torque (N • m): TPS43=3.5



RECOMMENDED CUTTING CONDITIONS

CUTTING SPEED

Material	Hardness	Grade	Breaker	ae			
				<0.15DC	0.15-0.3DC	DC (Slot)	
P Mild Steel	<180HB	MP6120	VP15TF	M H	200(160-250)	160(120-200)	140(120-160)
		MP6130	VP20RT	M H	170(130-220)	130(90-170)	110(90-130)
	180-350HB	MP6120	VP15TF	M H	160(120-200)	120(100-140)	100(80-120)
		MP6130	VP20RT	M H	130(90-170)	90(70-110)	70(50-90)
M Stainless Steel	<270HB	MP7130	VP15TF	M H	160(120-200)	120(100-140)	100(80-120)
K Gray Cast Iron	<350MPa	MC5020	—	H	230(180-280)	190(140-240)	190(140-240)
	<800MPa	MC5020	—	H	190(140-220)	170(120-220)	170(120-220)
S Titanium Alloy	<350HB	MP9120	VP15TF	H M	50(40-70)	—	50(40-70)
		MP9130	VP20RT	H M	40(30-60)	—	40(30-60)
	—	MP9120	VP15TF	H M	40(30-60)	—	40(30-60)
		MP9130	VP20RT	H M	30(20-40)	—	30(20-40)

DEPTH OF CUT / FEED PER TOOTH

Material	Hardness	ae	ap	fz		
				DC		
				Ø40 APMX 56mm Ø50 APMX 42mm	Ø50 APMX 56mm Ø63 APMX 56mm	Ø50 APMX 84mm
P Mild Steel	<180HB	<0.3DC	<20	0.25	0.25	0.20
			20-50	0.20	0.20	0.15
		1.0DC	50-80	—	—	0.10
			<20	0.20	0.20	0.15
Carbon Steel Alloy Steel	180-350HB	<0.3DC	<20	0.25	0.25	0.20
			20-50	0.20	0.20	0.15
		1.0DC	50-80	—	—	0.10
			<20	0.15	0.15	0.10
M Stainless Steel	<270HB	<0.3DC	<20	0.25	0.25	0.20
			20-50	0.20	0.20	0.15
		1.0DC	50-80	—	—	0.10
			<10	0.10	0.10	0.07
K Gray Cast Iron	Tensile Strength <350MPa	<0.15DC	<10	0.30	0.30	0.25
			10-50	0.25	0.25	0.20
		0.15-0.3DC	50-80	—	—	0.15
			<10	0.25	0.25	0.20
	1.0DC	10-50	0.20	0.20	0.15	
		50-80	—	—	0.10	
		<10	0.25	0.25	0.20	
		10-50	0.20	0.20	0.15	
Ductile, Cast Iron	Tensile Strength <800MPa	<0.15DC	<20	0.25	0.25	0.20
			20-50	0.20	0.20	0.15
		0.15-0.3DC	50-80	—	—	0.10
			<20	0.20	0.20	0.15
S Titanium Alloy	<350HB	<0.15DC	<20	0.10	0.10	—
			20-50	0.10	0.10	—
		1.0DC	<50	0.08	0.08	—
			<0.15DC	<10	0.07	0.07
Heat-resistant Alloy	—	1.0DC	<20	0.05	0.05	—
			<20	0.05	0.05	—

1. The above cutting conditions are determined based on high rigidity machine and workpiece, where no vibration occurred. Please adjust processing conditions if the vibration is generated.

INSERTS

Material	Cutting Conditions (Guide)	Honing
P Steel	● ✖	● ✖
M Stainless Steel	● ✖	● ✖
K Cast Iron	● ✖	● ✖
S Heat-resistant Alloy, Titanium Alloy	● ✖	● ✖
H Hardened Steel	● ✖	● ✖

● : Stable Cutting
 ◐ : General Cutting
 ✖ : Unstable Cutting
 E: Round
 F: Sharp
 T: Chamfer

Order Number	Class	Honing	MC5020	MP6120	MP6130	MP7130	MP9120	MP9130	VP15TF	VP20RT	L	LE	W1	S	BS	RE	Geometry	Shape
AOMT184804PEER-M	M	E	●	●	●	●	●	●	●	●	18	15	9	4.8	1.8	0.4		
AOMT184808PEER-M	M	E	●	●	●	●	●	●	●	18	15	9	4.8	1.4	0.8			
AOMT184810PEER-M	M	E	●				●	●	●	●	18	15	9	4.8	1.0	1.0		
AOMT184812PEER-M	M	E	●				●	●	●	●	18	15	9	4.8	0.8	1.2		
AOMT184816PEER-M	M	E	●	●	●	●	●	●	●	●	18	15	9	4.8	0.4	1.6		
AOMT184820PEER-M	M	E	●				●	●	●	●	18	15	9	4.8	0.4	2.0		
AOMT184804PEER-H	M	E	●	●	●	●	●	●	●	●	18	15	9	4.8	1.8	0.4		
AOMT184808PEER-H	M	E	●	●	●	●	●	●	●	●	18	15	9	4.8	1.4	0.8		
AOMT184816PEER-H	M	E	●	●	●	●	●	●	●	●	18	15	9	4.8	0.4	1.6		
AOMT184832PEER-H	M	E	●	●				●	●	●	18	15	9	4.8	0.4	3.2		
AOMT184840PEER-H	M	E	●	●				●	●	●	18	15	9	4.8	0.4	4.0		
AOMT184850PEER-H	M	E	●	●				●	●	●	18	15	9	4.8	-	5.0		
AOMT184864PEER-H	M	E	●	●				●	●	●	18	15	9	4.8	-	6.35		

NOTE ON USE OF INSERTS WITH LARGE CORNER RADII

When using inserts with corner radius $RE > R3.2$, please machine the holder with a radius form as shown on the right.

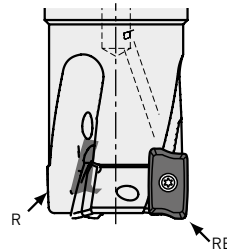

RE (mm)	R (mm)
3.2	2.0
4.0	2.5
5.0	3.5
6.35	5.0

R: Holder end radius
RE: Insert corner radius

ARBORS

ARBORS FOR SCREW-IN TOOLS

STRAIGHT SHANK ARBOR

	Order Number	★ Stock	DCB	DCONMS	DCONWS	LF	LB	H	CRKS	Geometry
STEEL SHANK TYPE	SC16M08S100S	★	8.5	16	14.5	100	10	10	M8	
	SC16M08S200L	★	8.5	16	14.5	200	10	10	M8	
	SC20M10S120S	★	10.5	20	18.5	120	10	14	M10	
	SC20M10S220L	★	10.5	20	18.5	220	10	14	M10	
	SC25M12S125S	★	12.5	25	23.5	125	10	19	M12	
	SC25M12S245L	★	12.5	25	23.5	245	10	19	M12	
	SC32M16S140S	★	17	32	28.5	140	15	24	M16	
	SC32M16S280L	★	17	32	28.5	280	15	24	M16	
CARBIDE SHANK TYPE	SC16M08S100SW	★	8.5	16	14.5	100	10	10	M8	
	SC16M08S200LW	★	8.5	16	14.5	200	10	10	M8	
	SC20M10S120SW	★	10.5	20	18.5	120	10	14	M10	
	SC20M10S220LW	★	10.5	20	18.5	220	10	14	M10	
	SC25M12S125SW	★	12.5	25	23.5	125	10	19	M12	
	SC25M12S245LW	★	12.5	25	23.5	245	10	19	M12	
	SC32M16S140SW	★	17	32	28.5	140	15	24	M16	
	SC32M16S280LW	★	17	32	28.5	280	15	24	M16	

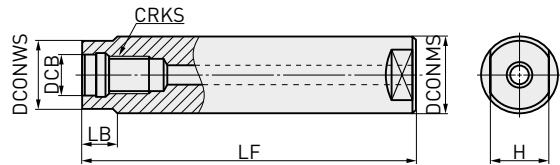

HOW TO INSTALL THE SCREW-IN HEAD

1. Thoroughly clean the clamping section of the head and the arbor with an air blower or brush before installation.
2. Tighten the head to the recommended torque and ensure there is no gap between the head and arbor.

Screw Size	Recommended Torque (N • m)	Wrench Size (mm)
M8	23	10
M10	46	14
M12	80	19
M16	90	24



Cutting tools become extremely hot during cutting. Never touch them with bare hands after operation as this may produce risk of injuries or burns. Do not handle the cutting tools with bare hands as this may cause injuries.

BT30 SHANK ARBOR

(mm)

Order Number	Stock	DCB	DCONWS	LPR	LB	CRKS
SC16M08S10-BT30	★	8.5	14.5	32	10	M8
SC20M10S10-BT30	★	10.5	18.5	32	10	M10
SC25M12S10-BT30	★	12.5	23.5	32	10	M12
SC32M16S10-BT30	★	17.0	28.5	32	10	M16

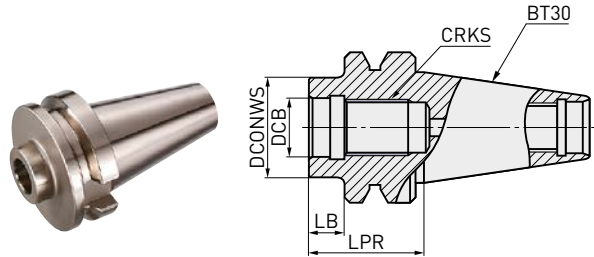

BT40 SHANK ARBOR

(mm)

Order Number	Stock	DCB	DCONWS	LPR	LB	CRKS
SC16M08S10-BT40	★	8.5	14.5	37	10	M8
SC20M10S10-BT40	★	10.5	18.5	37	10	M10
SC25M12S10-BT40	★	12.5	23.5	37	10	M12
SC32M16S10-BT40	★	17.0	28.5	37	10	M16

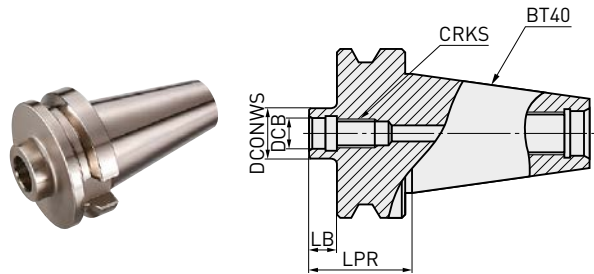

HSK63A SHANK ARBOR

(mm)

Order Number	Stock	DCB	DCONWS	LPR	LB	CRKS
SC16M08S22-HSK63A	★	8.5	14.5	48	22	M8
SC20M10S24-HSK63A	★	10.5	18.5	50	24	M10
SC25M12S27-HSK63A	★	12.5	23.5	53	27	M12
SC32M16S28-HSK63A	★	17.0	28.5	54	28	M16

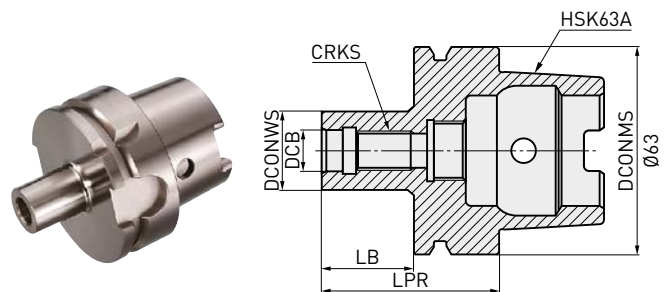

GERMANY

MMC HARTMETALL GMBH
Comeniusstr. 2 . 40670 Meerbusch
Phone +49 2159 91890 . Fax +49 2159 918966
Email admin@mmchg.de

U.K.

MMC HARDMETAL U.K. LTD.
Mitsubishi House . Galena Close . Tamworth . Staffs. B77 4AS
Phone +44 1827 312312 . Fax +44 1827 312314
Email sales@mitsubishicarbide.co.uk

SPAIN

MITSUBISHI MATERIALS ESPAÑA, S.A.
Calle Emperador 2 . 46136 Museros /Valencia
Phone +34 96 1441711 . Fax +34 96 1443786
Email mme@mmevalencia.com

FRANCE

MMC METAL FRANCE S.A.R.L.
6, Rue Jacques Monod . 91400 Orsay
Phone +33 1 69 35 53 53 . Fax +33 1 69 35 53 50
Email mmfsales@mmc-metal-france.fr

POLAND

MMC HARDMETAL POLAND SP. Z O.O
Al. Armii Krajowej 61 . 50-541 Wrocław
Phone +48 71335 1620 . Fax +48 71335 1621
Email sales@mitsubishicarbide.com.pl

RUSSIA

MMC HARDMETAL RUSSIA OOO LTD.
Electrozavodskaya St. 24 . build. 3 . Moscow . 107023
Phone +7 495 725 58 85 . Fax +7 495 981 39 79
Email info@mmc-carbide.ru

ITALY

MMC ITALIA S.R.L.
Via Montefeltro 6/A . 20156 Milano
Phone +39 0293 77031 . Fax +39 0293 589093
Email info@mmc-italia.it

TURKEY

MMC HARTMETALL GMBH ALMANYA - İZMİR MERKEZ ŞUBESİ
Adalet Mahallesi Anadolu Caddesi No: 41-1 . 15001 35580 Bayraklı /İzmir
Phone +90 232 5015000 . Fax +90 232 5015007
Email info@mmchg.com.tr

www.mitsubishicarbide.com | www.mmc-hardmetal.com

DISTRIBUTED BY:

□

□

L

┘

